



# Digital Cylinder AX (Z5) SmartIntego

---

Manual

25.02.2025

**Simons  Voss**  
technologies

## Contents

<b>1.</b>	<b>Intended use.....</b>	<b>5</b>
<b>2.</b>	<b>General safety instructions .....</b>	<b>6</b>
<b>3.</b>	<b>Product-specific safety instructions .....</b>	<b>9</b>
<b>4.</b>	<b>AP-specific safety instructions .....</b>	<b>11</b>
<b>5.</b>	<b>Structure.....</b>	<b>12</b>
5.1	Mechanical thumb-turn .....	13
5.2	Electronic thumb-turn .....	13
5.3	Comfort cylinder (CO; reader on one side) .....	14
5.4	Freely-rotating cylinder (FD; reader on both sides) .....	14
5.5	Half cylinder (HZ, reader on one side) .....	15
5.5.1	Scandinavian Oval (SO).....	15
5.5.2	Scandinavian Round – (RS).....	16
5.6	Structure of Lever Cylinder AX.....	16
5.7	Structure of Glass Door Cylinder AX design.....	17
<b>6.</b>	<b>Basic configuration, profiles and features.....</b>	<b>18</b>
6.1	Basic configuration .....	19
6.1.1	Comfort cylinder (CO; reader on one side) .....	19
6.1.2	Freely-rotating cylinder (FD; reader on both sides) .....	19
6.1.3	Half cylinder (HZ, reader on one side) .....	19
6.1.4	Glass door cylinder (short cylinder 25-15).....	19
6.1.5	Lever cylinder (LE).....	19
6.2	Profiles .....	19
6.2.1	Standard Euro profile cylinder as per to DIN 18252 / EN1303.....	19
6.2.2	Swiss round (SR) .....	20
6.2.3	Scandinavian oval (SO) .....	20
6.2.4	Scandinavian Round – (RS).....	21
6.3	Versions.....	21
6.3.1	Anti-panic (AP) .....	21
6.3.2	Brass version (MS) .....	22
6.3.3	Waterproof version (WP) .....	23
6.3.4	Multi-point (MR).....	23
6.3.5	VdS version Class BZ (VDS).....	23
6.3.6	Seawater-resistant version (SW).....	23
6.3.7	Without thumb-turn (OK) .....	24
6.3.8	Self-locking (SL) .....	24
<b>7.</b>	<b>Accessories.....</b>	<b>25</b>
7.1	Special tools .....	25

7.2	Components .....	26
7.2.1	LockNode .....	26
7.2.2	Replacement caps .....	26
7.2.3	Length modularity .....	27
7.2.4	Core extension .....	28
7.2.5	Thumb-turns .....	29
7.2.6	Grip ring .....	31
7.2.7	Cam .....	31
7.2.8	Lever .....	32
<b>8.</b>	<b>Programming .....</b>	<b>34</b>
<b>9.</b>	<b>Installation .....</b>	<b>35</b>
9.1	Comfort cylinder/anti-panic cylinder (CO/AP, reader on one side) .....	35
9.1.1	Standard installation/initial installation .....	35
9.1.2	Installation with clip-on cover plates .....	39
9.2	Freely-rotating cylinder (FD; reader on both sides) .....	50
9.2.1	Standard installation .....	50
9.2.2	Installation with clip-on cover plates .....	58
9.3	Half cylinder (HZ, reader on one side) .....	67
9.3.1	Standard installation .....	67
9.3.2	Installation with clip-on cover plate .....	68
9.4	Scandinavian oval/round (SO/RS) .....	76
9.4.1	Installation .....	76
9.5	Installing the Glass Door Cylinder AX .....	78
9.6	Installing the lever cylinder .....	81
9.7	Functional test .....	85
9.8	AP functional test .....	85
<b>10.</b>	<b>Customise Cylinder AX .....</b>	<b>88</b>
10.1	LockNode .....	88
10.1.1	Remove cap .....	88
10.1.2	Installation .....	90
10.1.3	Attach the cap .....	92
10.2	Replacement caps .....	93
10.2.1	Remove cap .....	93
10.2.2	Attach the cap .....	95
10.3	Length modularity .....	96
10.3.1	Extend Cylinder AX .....	96
10.3.2	Shorten Cylinder AX .....	109
10.3.3	Combine CO cylinders to FD .....	121
10.3.4	Reduce CO cylinders to HZ .....	136
10.4	Core extension .....	148

10.4.1	Scope of delivery.....	149
10.4.2	Installation.....	149
10.5	Escape knob.....	160
10.5.1	Installation on fitted cylinder (clockwise unlocking).....	160
10.5.2	Installation on the removed cylinder (anticlockwise unlocking).....	165
10.6	Replacing the cam.....	179
10.7	Replacing the lever.....	191
10.8	Incompatible hardware versions of nodes and cores.....	193
<b>11.</b>	<b>Signalling.....</b>	<b>195</b>
<b>12.</b>	<b>Maintenance.....</b>	<b>196</b>
12.1	Battery replacement.....	196
12.2	Cleaning and disinfection.....	201
<b>13.</b>	<b>Technical specifications.....</b>	<b>202</b>
13.1	Euro Profile and SwissRound.....	202
13.2	Scandinavian Oval Scandinavian Round.....	203
13.3	Dimensions.....	204
13.3.1	Cam dimensions.....	206
13.3.2	Lever dimensions.....	209
<b>14.</b>	<b>Declaration of conformity.....</b>	<b>212</b>
<b>15.</b>	<b>Help and other information.....</b>	<b>213</b>

## 1. Intended use

You can install SI Digital Cylinder AX (Z5) in door locks designed for this purpose (e.g. DIN mortise locks) and integrate them into a digital locking system.

The SI Digital Cylinder AX is available in various lengths and versions. Make sure that your SI Digital Cylinder AX has the correct length. You can measure the length of your SI Digital Cylinder AX at any time and adjust it yourself.

- If the SI Digital Cylinder AX is too short, you cannot mount the thumb-turns.
- If the SI Digital Cylinder AX is too long, the SI Digital Cylinder AX can be torn out of the lock.

Do not modify the SI Digital Cylinder AX (except to carry out modifications described in this manual).

## 2. General safety instructions

### Signal word: Possible immediate effects of non-compliance

DANGER: Death or serious injury (likely)

WARNING: Death or serious injury (possible, but unlikely)

CAUTION: Minor injury

IMPORTANT: Property damage or malfunction

NOTE: Low or none



### WARNING

#### Blocked access

Access through a door may stay blocked due to incorrectly fitted and/or incorrectly programmed components. SimonsVoss Technologies GmbH is not liable for the consequences of blocked access such as access to injured or endangered persons, material damage or other damage!

#### Blocked access through manipulation of the product

If you change the product on your own, malfunctions can occur and access through a door can be blocked.

- ❑ Modify the product only when needed and only in the manner described in the documentation.

#### Do not swallow battery. Danger of burns from hazardous substances

This product contains lithium button cell batteries. Swallowing the button cell battery, in can result in severe internal burns leading to death in as little as two hours.

1. Keep new and used batteries away from children.
2. If the battery compartment does not close securely, cease using the product and keep it away from children.
3. If you think batteries have been swallowed or are in any part of the body, seek medical attention immediately.

#### Risk of explosion due to incorrect battery type

Inserting the wrong type of battery can cause an explosion.

- ❑ Only use the batteries specified in the technical data.



### CAUTION

#### Fire hazard posed by batteries

The batteries used may pose a fire or burn hazard if handled incorrectly.

1. Do not try to charge, open, heat or burn the batteries.
2. Do not short-circuit the batteries.

## **IMPORTANT**

### **Damage resulting from electrostatic discharge (ESD) when enclosure is open**

This product contains electronic components that may be damaged by electrostatic discharges.

1. Use ESD-compliant working materials (e.g. Grounding strap).
2. Ground yourself before carrying out any work that could bring you into contact with the electronics. For this purpose, touch earthed metallic surfaces (e.g. door frames, water pipes or heating valves).

### **Damage resulting from liquids**

This product contains electronic and/or mechanic components that may be damaged by liquids of any kind.

- ❑ Keep liquids away from the electronics.

### **Damage resulting from aggressive cleaning agents**

The surface of this product may be damaged as a result of the use of unsuitable cleaning agents.

- ❑ Only use cleaning agents that are suitable for plastic or metal surfaces.

### **Damage as a result of mechanical impact**

This product contains electronic components that may be damaged by mechanical impacts of any kind.

1. Avoid touching the electronics.
2. Avoid other mechanical influences on the electronics.

### **Damage due to polarity reversal**

This product contains electronic components that may be damaged by reverse polarity of the power source.

- ❑ Do not reverse the polarity of the voltage source (batteries or mains adapters).

### **Operational malfunction due to radio interference**

This product may be affected by electromagnetic or magnetic interference.

- ❑ Do not mount or place the product directly next to devices that could cause electromagnetic or magnetic interference (switching power supplies!).

### **Communication interference due to metallic surfaces**

This product communicates wirelessly. Metallic surfaces can greatly reduce the range of the product.

- ❑ Do not mount or place the product on or near metallic surfaces.
-



#### NOTE

##### Intended use

SmartIntego-products are designed exclusively for opening and closing doors and similar objects.

- ❑ Do not use SmartIntego products for any other purposes.

##### Malfunctions due to poor contact or different discharge

Contact surfaces that are too small/contaminated or different discharged batteries can lead to malfunctions.

1. Only use batteries that are approved by SimonsVoss.
2. Do not touch the contacts of the new batteries with your hands.
3. Use clean and grease-free gloves.
4. Always replace all batteries at the same time.

##### Different times for G2 locks

The internal time unit of the G2 locks has a technical tolerance of up to  $\pm 15$  minutes per year.

- ❑ Regularly reprogram time-critical locking devices.

##### Qualifications required

The installation and commissioning requires specialized knowledge.

- ❑ Only trained personnel may install and commission the product.

##### Incorrect installation

SimonsVoss Technologies GmbH accepts no liability for damage caused to doors or components due to incorrect fitting or installation.

Modifications or further technical developments cannot be excluded and may be implemented without notice.

The German language version is the original instruction manual. Other languages (drafting in the contract language) are translations of the original instructions.

Read and follow all installation, installation, and commissioning instructions. Pass these instructions and any maintenance instructions to the user.



### 3. Product-specific safety instructions



#### WARNING

##### Blocking of escape routes due to faulty function

If mortise locks with panic function are to be used together with a locking cylinder, improper use of locking cylinders may result in the panic function not functioning properly.

1. Make sure that all parts of the closure are in working condition (EN 179).
2. Only install the cylinder in mortise locks for which it has been expressly approved (refer to the documentation of the lock manufacturer).

##### Locking in people as a result of closures or sealing strips on the door unit

If locks or sealing strips are attached to the door unit, the locking cylinder may not function properly.

- ❑ Make sure that any locks or sealing strips do not interfere with the operation of the locking cylinder.

#### IMPORTANT

##### Assembly error due to incorrect length

The SI Digital Cylinder AX is available in various lengths. If you order the wrong length, the SI Digital Cylinder AX cannot be installed correctly.

- ❑ Order your SI Digital Cylinder AX in the correct length or adjust the length yourself.

##### Mechanical damage to the thumb turn as a result of obstacles

If the thumb turn can knock against the wall or other objects as a result of the installation situation, it may become damaged.

- ❑ In such situations, use a suitable door stop.

##### Damage caused by moisture in outdoor use

Moisture can damage the electronics.

1. If you want to use the locking cylinder for outdoor applications or in high humidity (bathrooms or washrooms), use the WP version.
2. Carefully insert the locking cylinder to avoid damaging the O-rings.

##### Damage to the SI Digital Cylinder AX due to unsuitable tools

Special tools are required to open the cover and dismantle the SI Digital Cylinder AX. If you use unsuitable tools, you may damage the SI Digital Cylinder AX.

- ❑ Only use the separately available SimonsVoss special tool (*Accessories* [[▶ 25](#)]).



**NOTE**

**Locking up of persons without means of identification**

The freely-rotating construction of the closing cylinder can only be opened with a means of identification from both sides.

- Ensure that no persons without means of identification are in the secured area.

**Door obstructed by locking cylinder**

Make sure that the opening and closing of the door is not obstructed by the locking cylinder or parts thereof.

**Conditions for authorisation security**

Operation with Mifare Classic and/or PinCode keypad excludes authorisation security class D according to DIN EN 15684:2021.

**VdS conditions**

VdS approval for class BZ is subject to the following conditions:

1. Protect your VdS/SKG SI Digital Cylinder AX with burglar-resistant door plates B or C certified according to VdS/SKG (DIN 18257 class ES 2 or ES 3).
2. Make sure that the SI Digital Cylinder AX does not protrude more than 3 mm.
3. Do not use your SI Digital Cylinder AX with MIFARE Classic, PinCode keypad, BLE or WaveNet.

**SKG requirements**

The SKG classification SKG\*\*\* does not cover operation with a PIN code keypad. In this instance, the SKG classification obtained is only SKG\*\*.

**Fire resistance**

The fire resistance of the SI Digital Cylinder AX tested according to DIN EN 1634-2: 2009:05 for fire and smoke resistant doors (type: wood and wood-product fire protection doors with a resistance time of 90 minutes). The test report has the PfB number 18/11-A495-B1 (test institute for construction elements).

## 4. AP-specific safety instructions

For locking cylinders with anti-panic function, also observe the following safety instructions:



### WARNING

#### Escape door function malfunction

The use of unsuitable components or ones that are not ready for operation can impair the function of an escape door. If you use the anti-panic cylinder in non-approved locks, the escape door function may be impaired and cannot be released again.

1. Make sure that all parts of the lock are ready for operation.
2. Make sure that the panic function of the mortise lock is ensured.
3. Please refer to the documentation of the lock manufacturer.
4. Use the anti-panic cylinder within the specified temperature range.
5. Perform a function test after installing the anti-panic cylinder or changing its battery.

#### Malfunction of the anti-panic function due to unauthorised manipulation

In its anti-panic version, the SI Digital Cylinder AX has a permanently installed anti-panic module and is modular in length to a limited extent: outer side as required, inner side from 50 mm and half cylinder from 50 mm.

1. Do not attempt to dismantle the anti-panic module as this may damage it.
2. Perform a battery test every time that you modify it.



### CAUTION

#### Hand injuries from carrier springing back

A spring-loaded carrier is used in the anti-panic construction of the closing cylinder. This carrier can spring back when it is not installed, causing hand injuries.

- Do not hold the anti-panic construction of the closing cylinders in the area of the carrier.



### NOTE

#### Maintenance interval of not more than one month for emergency exit locks

As per European standard EN 179, Appendix C, all components in a locking device must be checked at intervals no greater than one month to ensure that they are in satisfactory working order as part of emergency exit locking device maintenance.

## 5. Structure



The SI Digital Cylinder AX has a modular construction. It always consists of a cylinder profile with drill protection and actuator integrated in the core with an external thumb-turn and optionally an internal thumb-turn.



The knobs are removable. However, the thumb-turn mounts of the electronic and mechanical thumb-turns are not compatible with each other. Electronic thumb-turns only fit on a mounting for electronic thumb-turns and mechanical thumb-turns fit on a mounting for mechanical thumb-turns.

You can now also use the SI Digital Cylinder AX with Euro profile (see *Standard Euro profile cylinder as per to DIN 18252 / EN1303 [▶ 19]*) to suit your individual needs (see *Length modularity [▶ 96]*):

- Recombine cylinders and replace thumb-turn mounts.
- Extend or shorten the cylinder profile for Euro profile cylinders.

The SI Digital Cylinder AX is supplied with batteries, which are located in the electronic thumb-turn.

## 5.1 Mechanical thumb-turn

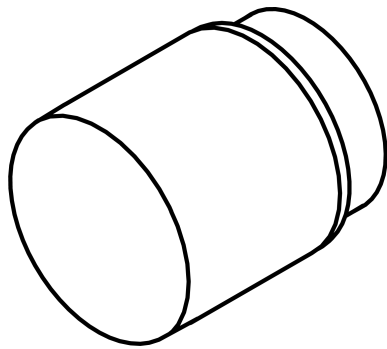

The mechanical knob is a single component. It consists of the knob housing with embossed logo and two magnetic pins for assembly and disassembly.

## 5.2 Electronic thumb-turn

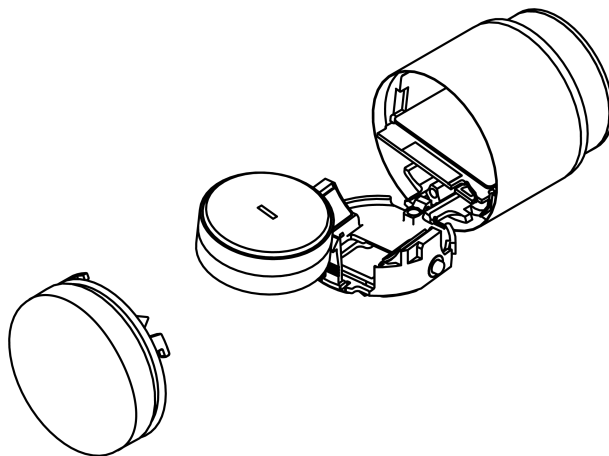

The electronic thumb-turn is composed of several components. Externally, it differs from the mechanical thumb-turn by:

- a door-side transparent cover for signalling
- a removable lid with printed logo

The lid is available in different designs and can be replaced (see *Components* [▶ 26]).

The electronic thumb-turn also contains:

- Mount for a network node (LNI)
- Holder for two batteries (CR2450) with reclosable flap
- Two replaceable CR2450 batteries (see *Battery replacement* [▶ 196] and *Technical specifications* [▶ 202])

### 5.3 Comfort cylinder (CO; reader on one side)

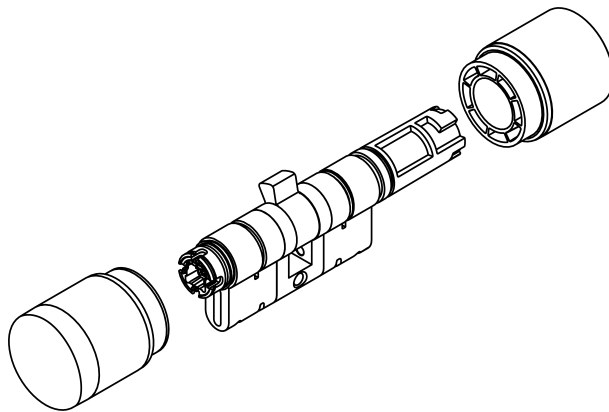

The comfort cylinder consists of:

- a mechanical thumb-turn
- an electronic thumb-turn
- a cylinder profile

### 5.4 Freely-rotating cylinder (FD; reader on both sides)

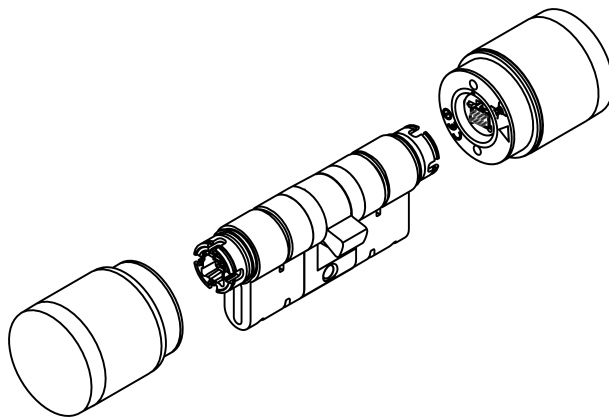

The freely-rotating cylinder consists of:

- two electronic thumb-turns
- a cylinder profile

### 5.5 Half cylinder (HZ, reader on one side)

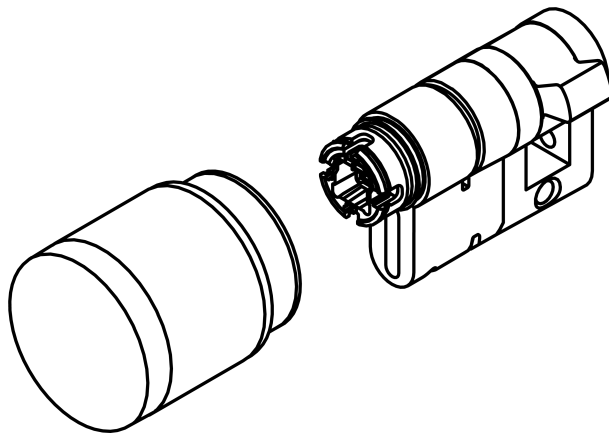

The half cylinder consists of:

- an electronic thumb-turn
- a cylinder profile

#### 5.5.1 Scandinavian Oval (SO)

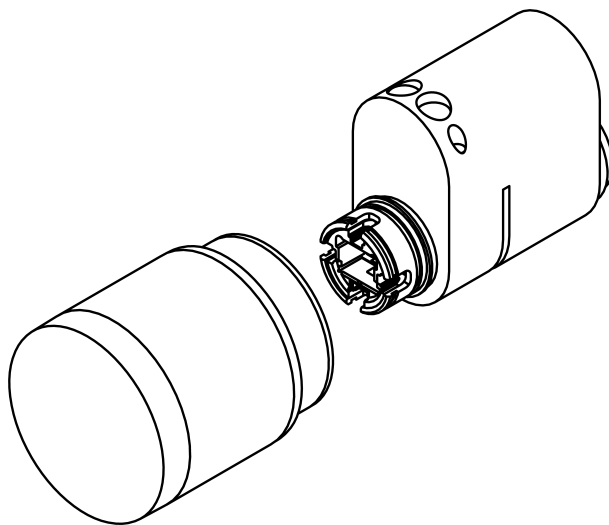

The SI Digital Cylinder AX for SO mortise locks is structured similarly to a half cylinder and consists of:

- an electronic thumb-turn
- a cylinder profile with tappet

The SI Digital Cylinder AX for SO mortise locks can be used in different ways:

- With a second SI Digital Cylinder AX for SO mortise locks (as freely rotating cylinder)
- With a mechanical cylinder for SO mortise locks (as comfort cylinder)
- Without other cylinders (as half cylinders)

### 5.5.2 Scandinavian Round – (RS)

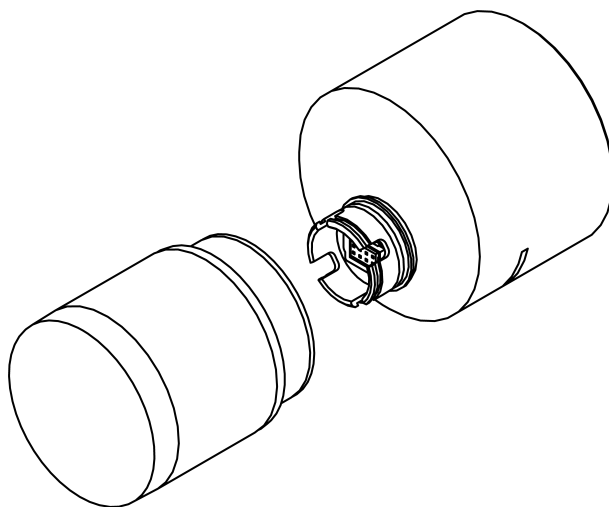

The SI Digital Cylinder AX for RS mortise locks is structured similarly to a half cylinder and consists of:

- an electronic thumb-turn
- a cylinder profile with tappet

The SI Digital Cylinder AX for RS mortise locks can be used in different ways:

- With a second SI Digital Cylinder AX for RS mortise locks (as freely rotating cylinder)
- With a mechanical cylinder for RS mortise locks (as comfort cylinder)
- Without other cylinders (as half cylinders)

### 5.6 Structure of Lever Cylinder AX

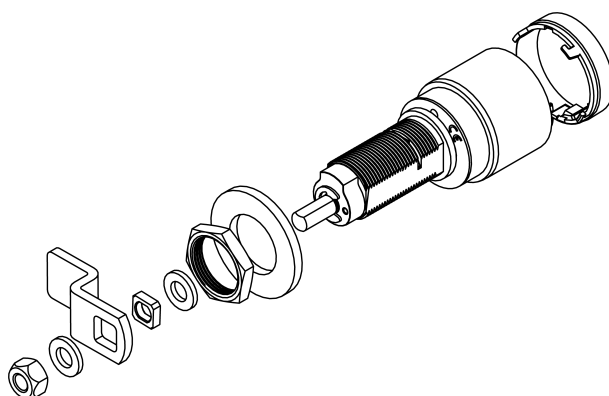



### 5.7 Structure of Glass Door Cylinder AX design

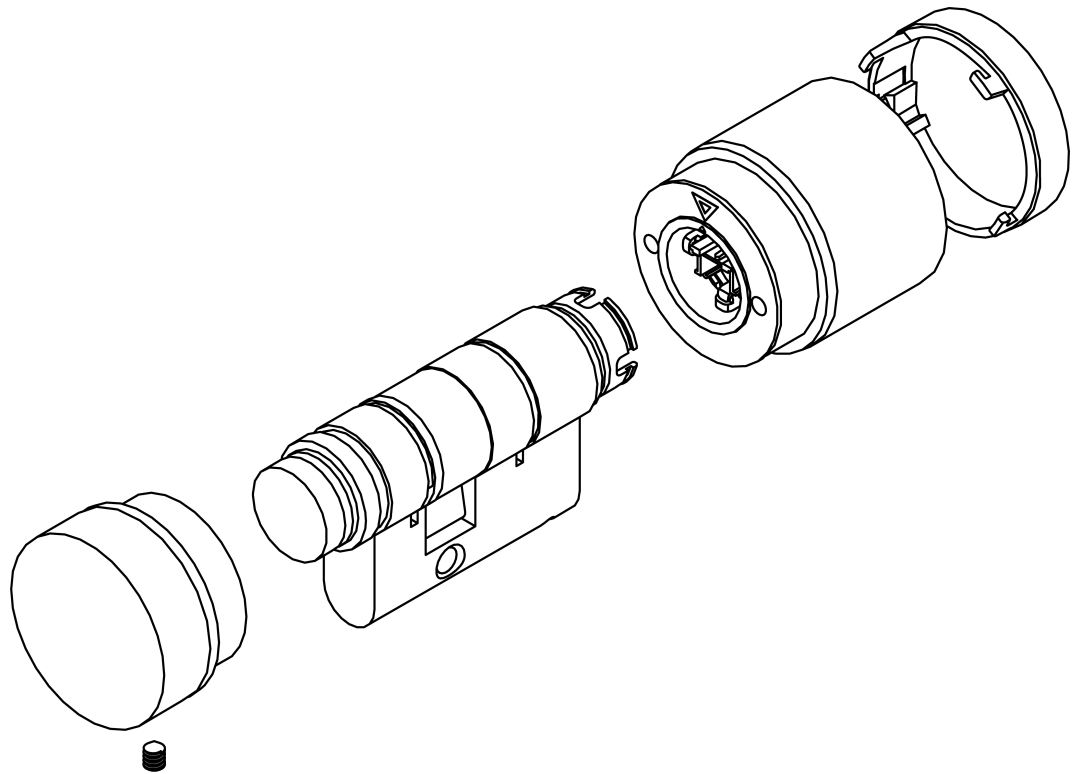

## 6. Basic configuration, profiles and features

The SI Digital Cylinder AX is available in different versions:

### Basic configuration

Also see *Basic configuration* [▶ 19].

CO	<i>Comfort cylinder (freely-rotating, one-sided mechanical) [▶ 19]</i>
FD	<i>Freely rotating (freely rotating on both sides) [▶ 19]</i>
HZ	<i>Half cylinder (freely rotating on one side) [▶ 19]</i>
25-15	<i>Glass door cylinder (short cylinder 25*15 mm) [▶ 19]</i>
LE	<i>Lever cylinder [▶ 19]</i>

### Profiles

Also see *Profiles* [▶ 19].

EU	<i>Standard (Euro profile cylinder as per DIN 18252 or EN 1303) [▶ 19]</i>
SR	<i>Swiss Round [▶ 20]</i>
SO	<i>Scandinavian Oval [▶ 20]</i>
RS	<i>Round Scandinavian [▶ 21]</i>

### Versions

Also see *Versions* [▶ 21].

AP	Anti-panic function
MS	<i>Brass version [▶ 22]</i>
WP	<i>Waterproof version [▶ 23] (see Technical specifications [▶ 202] for protection class)</i>
MR	<i>Multi-point [▶ 23]</i>
VDS	<i>VdS version Class BZ [▶ 23]</i>
SW	<i>Weatherproof design [▶ 23]</i>
OK	<i>Without thumb-turn [▶ 24]</i>
SL	<i>Self-locking [▶ 24]</i>

You can combine the variants described in the table to create a suitable SI Digital Cylinder AX for your needs. Please refer to the current product catalogue or price list for details on combinations and availability. The options are described in more detail in the following chapters.

## **6.1 Basic configuration**

### **6.1.1 Comfort cylinder (CO; reader on one side)**

In this version, a thumb-turn is mechanically connected to the locking cam. You can open and close the door from this side without an identification medium.

### **6.1.2 Freely-rotating cylinder (FD; reader on both sides)**

Both knobs are freely rotating in this design. You must have an identification medium to engage this locking cylinder.

### **6.1.3 Half cylinder (HZ, reader on one side)**

In this version, there is only an actuator or thumb-turn mount on one side of the lock bit.

#### **6.1.3.1 Scandinavian Oval (SO)**

This half cylinder fits locks with a Scandinavian round profile with a matching counterpart.

#### **6.1.3.2 Scandinavian Round – (RS)**

This half cylinder is fitted to locks with a Scandinavian round profile using a matching counterpart.

### **6.1.4 Glass door cylinder (short cylinder 25-15)**

This version is not modular. As a result, it is possible to have a shorter design, which is highly suitable for very thin door leaves such as those in glass doors.

### **6.1.5 Lever cylinder (LE)**

This version does not have a thumb-turn on the inner side, but instead features a mount for fitting different levers.

## **6.2 Profiles**

### **6.2.1 Standard Euro profile cylinder as per to DIN 18252 / EN1303**

In this version, the SI Digital Cylinder AX is supplied with a cylinder profile for Euro profile cylinders.



### 6.2.2 Swiss round (SR)

In this version, the SI Digital Cylinder AX is supplied with a cylinder profile for Swiss Round.



### 6.2.3 Scandinavian oval (SO)

In this version, the SI Digital Cylinder AX is supplied with a cylinder profile for Scandinavian Oval.



### 6.2.4 Scandinavian Round – (RS)

In this version, the SI Digital Cylinder AX supplied with a cylinder profile for Scandinavian Round.



## 6.3 Versions

### 6.3.1 Anti-panic (AP)

Doors can be fitted with mortise locks with panic function. In some mortise locks, the panic function can be blocked by certain positions of the tappet (area R).

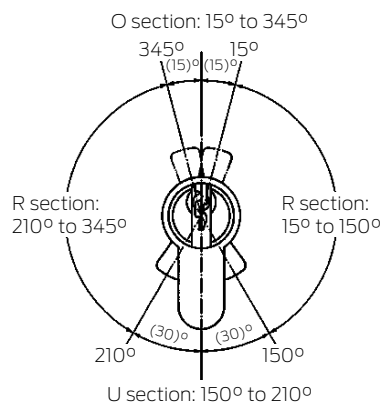

For these doors/mortise locks a SI Digital Cylinder AX with panic function (AP) must be used.

SI Digital Cylinder AX with panic function are equipped with a spring mechanism which always pulls the tappet into a non-critical position (area O or area U). This means that the tappet can no longer block the panic function of a panic lock.

Installation does not differ from installation of the normal comfort cylinder (see *Comfort cylinder/anti-panic cylinder (CO/AP, reader on one side)* [▶ 35]).

For doors built along escape routes after April 2003, the following points must be observed:

- All closures for which the approvals state that the SI Digital Cylinder AX does not affect the function of the lock, all SI Digital Cylinder AX can be used.
- For all closures in which the tappet position of the SI Digital Cylinder AX affects the function of the lock, the SI Digital Cylinder AX AP (anti-panic cylinder) may have to be used; this must be specified in the lock manufacturer's approval.



### DANGER

Due to the structural properties of panic locks, it is not permitted to turn the knob of the SI Digital Cylinder AX to the stop, as this can affect the lock's panic function.



### CAUTION

**Use of the anti-panic version of the locking cylinder in non-approved locks**

If you use the anti-panic version of the locking cylinder in unauthorised locks, the escape door function may be impaired and cannot be released again.

1. Only use the anti-panic version of the locking cylinder in locks for which the locking cylinder is expressly approved.
2. Please refer to the documentation of the respective lock manufacturer.
3. Contact SimonsVoss Technologies GmbH for further information on this subject (see *Help and other information* [▶ 213]).

#### 6.3.2 Brass version (MS)

In this version, the AX locking cylinder is supplied in brass colour instead of stainless steel colour. The thumb-turn covers are high-gloss.

The following images show the appearance as an example:





### 6.3.3 Waterproof version (WP)

This option equips the SI Digital Cylinder AX with additional seals. The SI Digital Cylinder AX is therefore waterproof (see *Technical specifications* [[▶ 202](#)]).

You can now also use the SI Digital Cylinder AX with this option outside for external doors or other areas exposed to high humidity (e.g. washrooms or bathrooms).

### 6.3.4 Multi-point (MR)

This option equips your SI Digital Cylinder AX with a locking bit with dedicated points. The locking bit engages at these points when disengaged. If you have a smooth-running lock with multi-point locking, you should use this option.

### 6.3.5 VdS version Class BZ (VDS)

With this option, the SI Digital Cylinder AX meets the requirements specified for VdS class BZ.



#### NOTE

#### VdS conditions

VdS approval for class BZ is subject to the following conditions:

1. Protect your VdS/SKG SI Digital Cylinder AX with burglar-resistant door plates B or C certified according to VdS/SKG (DIN 18257 class ES 2 or ES 3).
2. Make sure that the SI Digital Cylinder AX does not protrude more than 3 mm.
3. Do not use your SI Digital Cylinder AX with MIFARE Classic, PinCode keypad, BLE or WaveNet.

### 6.3.6 Seawater-resistant version (SW)

This option equips the Locking Cylinder AX (similar to the WP option; see *Waterproof version (WP)* [[▶ 23](#)]) with additional seals, a painted grip element and a specially polished V4A thumb-turn, which are all also suitable for use in maritime environments. Maritime environments include:

- Maritime shipping

- Coastal ports
- Other use situations with saline water in the immediate vicinity

### **6.3.7 Without thumb-turn (OK)**

With this option, the AX locking cylinder is supplied without a thumb-turn on the inside.

### **6.3.8 Self-locking (SL)**

This option equips the half cylinder with a self-locking function (spring-loaded cam with fixed reset position). With this option, you can lock the SI Digital Cylinder AX without an ID medium. You press the SI Digital Cylinder AX in instead. The attached bevel pushes the suspension back and locks the SI Digital Cylinder AX without an ID medium.

You can use this option to enhance security for switch cabinets, distribution boxes and server cabinets that are equipped with a gear lever handle.



## 7. Accessories

### 7.1 Special tools

	Product	Description	Item order code
	Special tool	<p>You can use this special tool to:</p> <ul style="list-style-type: none"> <li>■ Dismantle thumb-turns.</li> <li>■ Remove the cover of the electronic thumb-turn.</li> </ul> <p>Also included is a 1.5 mm hexagonal key for dismantling the electronic thumb-turn.</p>	Z5.TOOL
	Lifter	<p>You can use this special tool to:</p> <ul style="list-style-type: none"> <li>■ Pull clamps out of the profile cylinders.</li> <li>■ Unscrew and screw in the bolts in the profile cylinder.</li> </ul>	Z5.LIFTER
	Spacer	<p>You can use this special tool to align the distance of the bolt when assembling the profile cylinder housing.</p>	Z5.SPACER
	Terminal block	<p>You can use this special tool to push the clamps into the profile cylinder housing when assembling the profile cylinder housing.</p>	Z5.BLOCK

## 7.2 Components

### 7.2.1 LockNode

LockNodes are used to network your SI Digital Cylinder AX. The two SmartIntego product families WO (Wireless Online) and VCN (Virtual Card Network) are different:

- WO: LockNode pre-installed ex works can be replaced if required.
- VCN: cannot be combined with LockNodes.



The SI Digital Cylinder AX then also powers the LockNode with its batteries. A spring-loaded pin comes into contact with the cap on the reader thumb-turn after assembly to communicate wirelessly in a similar way to an antenna.

The LockNode is supplied with a suitable replacement cap (see *Replacement caps* [▶ 26]).



### 7.2.2 Replacement caps

The cap that locks the electronic thumb-turn is replaceable (see *Replacement caps* [▶ 93]). The following replacement caps are available:

	<p>Plastic cap for SI Digital Cylinder AX in a virtual card network (SV-Z5.TT.CAP.P)</p>
---	--







	<p>Plastic cap for SI Digital Cylinder AX in wireless online networks</p> <p>With integrated antenna for use with a LockNode</p> <p>(SV-Z5.TT.CAP.P.AN)</p>
---	---

### 7.2.3 Length modularity

Extension bolt	Core extension for the profile	Profile extension
 <ul style="list-style-type: none"> <li>■ Z5.BOLT.XX (XX = required basic length)</li> </ul>	 <ul style="list-style-type: none"> <li>■ Z5.CORE.05: 5 mm</li> <li>■ Z5.CORE.10: 10 mm</li> <li>■ Z5.CORE.20: 20 mm</li> </ul>	 <ul style="list-style-type: none"> <li>■ Z5.PROFILE.05: 5 mm</li> <li>■ Z5.PROFILE.10: 10 mm</li> <li>■ Z5.PROFILE.20: 20 mm</li> </ul>

### Clamps

 <ul style="list-style-type: none"> <li>■ Z5.CLAMPS</li> </ul> <p>Set contains 50 units.</p>
---

Cylinder centre piece	Half cylinder centre piece	Half cylinder centre section with multi-point
		
■ Z5.CNT.EU	■ Z5.CNT.HZ	■ Z5.CNT.HZ.MR
Inner thumb-turn mount	Inside blank profile without thumb-turn	Thumb-turn mount for glass door thumb-turn
		
■ Z5.PR.IN	For .OK variant ■ Z5.PR.OK	Profile length 30 mm (extensible) ■ Z5.PR.GD

#### 7.2.4 Core extension

Core protection adapters are used if the gap between the thumb-turn and the cylinder profile needs to be increased. This may be necessary the cylinder is to be installed in a protective fitting or a round hole fitting.

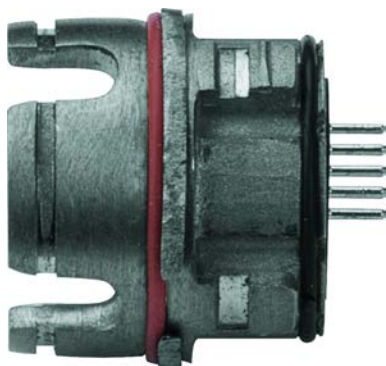

The core extension for your SI Digital Cylinder AX is available in various lengths:

- Z5.KA: 8 mm
- Z5.KA.12: 12mm

For more information see *Core extension* [▶ 148].

### 7.2.5 Thumb-turns

#### Inside thumb-turn

The inside thumb-turn (SV-Z5.TT.IN) is also available separately for your Comfort cylinders.



#### Escape thumb-turn

The escape thumb-turn (SV-Z5.TT.EC) is also available for your Comfort cylinders.



The escape thumb-turn for the Digital Cylinder AX is equipped with a ratchet function. It replaces the inside thumb-turn of a comfort cylinder.

- Unlocking from inside possible at any time without an identification medium
- Locking only possible from the outside and only with an identification medium.

The escape thumb-turn is suitable for DIN L and DIN R doors. Simply adjust the direction of rotation when it is removed.

People can escape rooms fitted with comfort cylinders and escape thumb-turns at any time.

See *Escape knob* [▶ 160] for installation.

#### **Glass door cylinder thumb-turn**

A special thumb-turn is available for your glass door cylinder (SV-Z5.TT.GD).



This thumb-turn impresses due to its low installation height and is eminently suitable for cylinders installed in glass doors. It is fastened onto a threaded thumb-turn mount and secured with a grub screw.

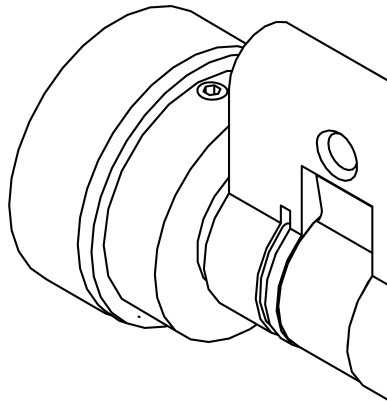

See *Installing the Glass Door Cylinder AX* [▶ 78] for installation.

You therefore need a glass door cylinder inside thumb-turn mount (Z5.PR.GD) and a 10 mm core extension (Z5.CORE.10) to install on modular Comfort cylinders. This allows you to use the shortened thumb-turn on shell-type handles in gymnasiums, for example.

#### 7.2.6 Grip ring







The grip ring for inside thumb-turns is also available as a separate spare part (Z5.TT.GR). One packaging unit contains five grip rings.

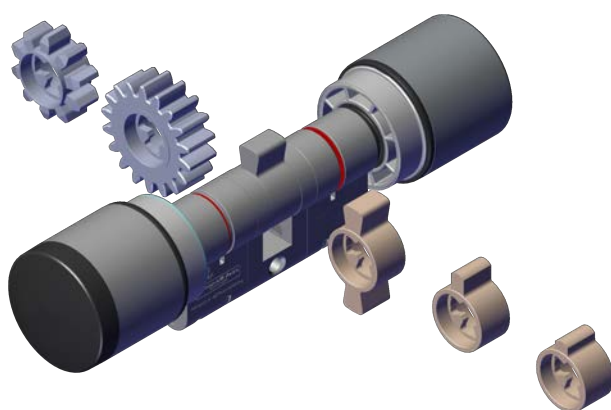

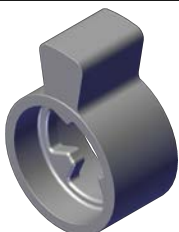
#### 7.2.7 Cam

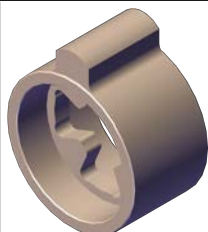
You can also choose between different cams:



Standard cam	Cam PM1 (long)	Cam PM2 (short)
 <p>■ Z5.CAM.WP</p>	 <p>■ Z5.CAM.PM1</p>	 <p>■ Z5.CAM.PM2</p>
Double cam	Cam gear, 10 teeth	Cam gear, 18 teeth
 <p>■ Z5.CAM.DOUBLE</p>	 <p>■ Z5.CAM.GEAR10</p>	 <p>■ Z5.GEAR.18</p>



Dimensional drawings can be found in Section *Cam dimensions* [▶ 206]; see *Replacing the cam* [▶ 179] for installation.

### 7.2.8 Lever

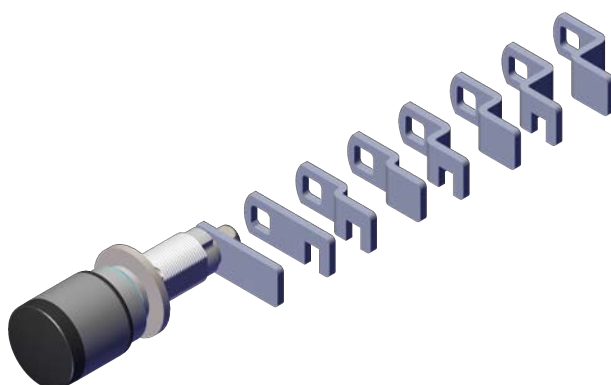
You can also choose other levers for your SI Digital Lever Cylinder AX:





 Z5.LE.11.01	 Z5.LE.11.02	 Z5.LE.11.03	 Z5.LE.11.04
 Z5.LE.12.01	 Z5.LE.12.02	 Z5.LE.12.03	 Z5.LE.12.04

Dimensional drawings can be found in Section *Lever dimensions* [[▶ 209](#)]; see *Replacing the lever* [[▶ 191](#)] for installation.

## 8. Programming

See system descriptions or step-by-step guides for Wireless Online and VirtualCard Network:

- *WO system description*
- *WO step-by-step guide*
- *VCN system description*
- *VCN step-by-step guide*

## 9. Installation

### IMPORTANT

#### Unauthorised access by drilling on the inside

The outside of the SI Digital Cylinder AX is equipped with drilling protection on the outside, depending on the version.

- If you find a mark on the inside (//N) of the cylinder body, mount the SI Digital Cylinder AX so that this side is in a protected area.

### 9.1 Comfort cylinder/anti-panic cylinder (CO/AP, reader on one side)

#### 9.1.1 Standard installation/initial installation

This is the easiest way to install the SI Digital Cylinder AX. You do not need any special tools for the initial assembly. Remove the red plastic assembly lock before initial assembly.

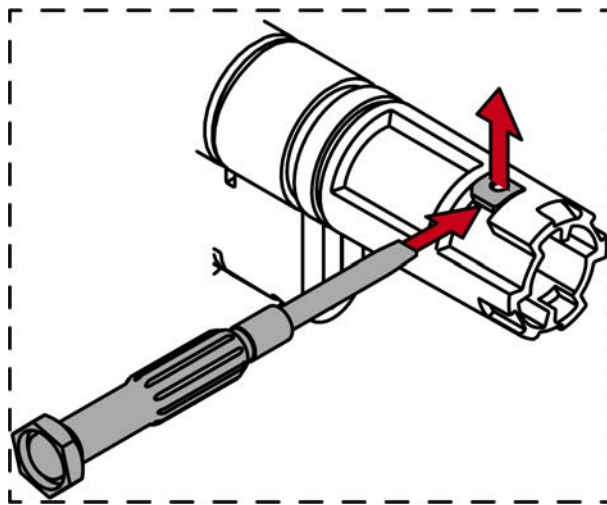

### NOTE

#### Tool-free initial assembly

The mechanical thumb-turn is only clipped on when delivered. A thumb-turn lock (red plastic part) prevents the thumb-turn from engaging. You can install the mechanical thumb-turn of the AX locking cylinder without tools, but you cannot disassemble it without special tools. When the AX locking cylinder is installed for the first time, it is therefore not necessary to disassemble the mechanical thumb-turn. Instead, start by inserting the AX locking cylinder.

- ✓ Special tool available.
  - ✓ PH2 screwdriver at hand.
1. Align the thumb turn horizontally.

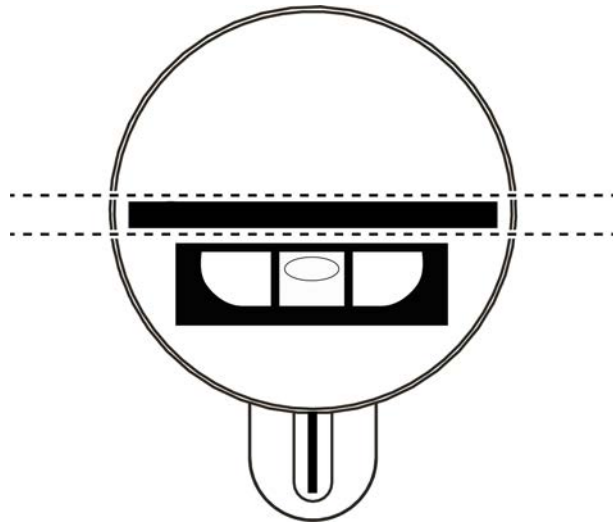

2. Attach the special tool.

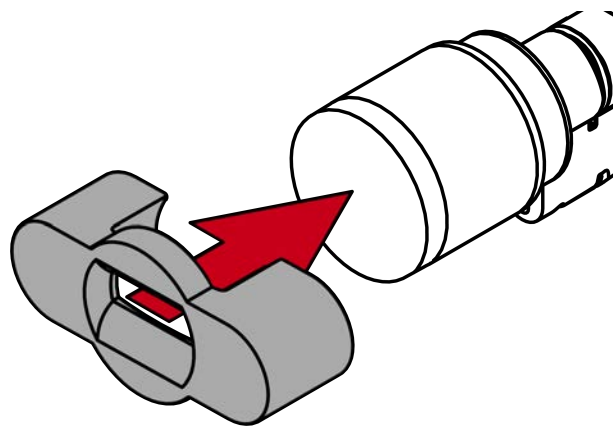

3. Align the special tool so that the logo is parallel to the recess.

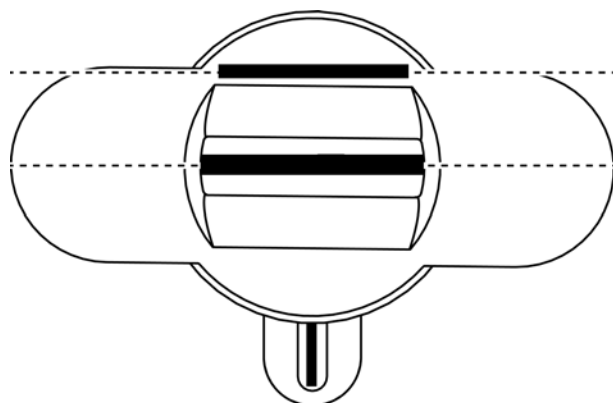

4. At the same time turn the special tool and the thumb-turn counter-clockwise.

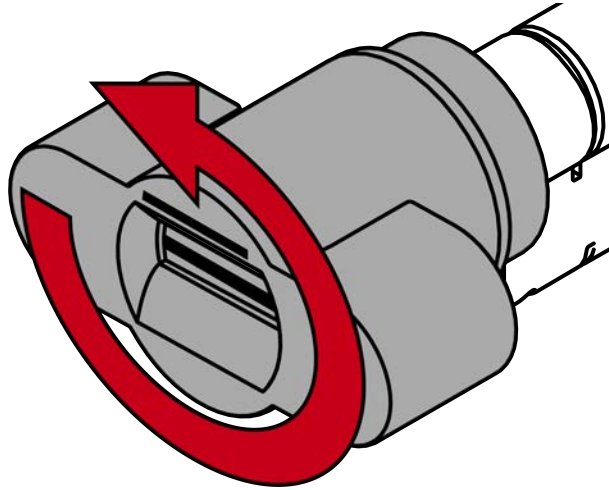

5. Remove the special tool and the thumb-turn at the same time.

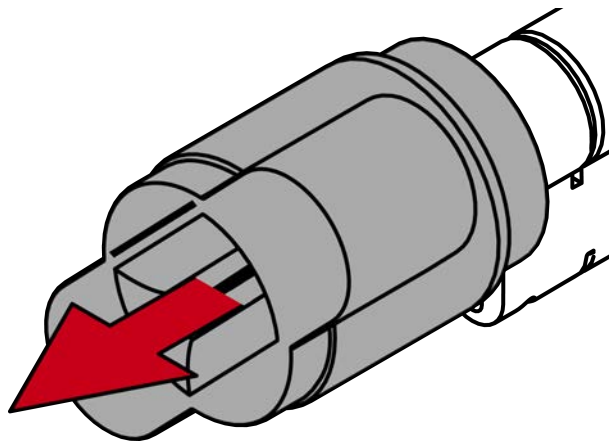

↳ The mechanical thumb-turn is disassembled.

6. Insert the SI Digital Cylinder AX into the mortise lock with the side without a thumb-turn facing the lock.

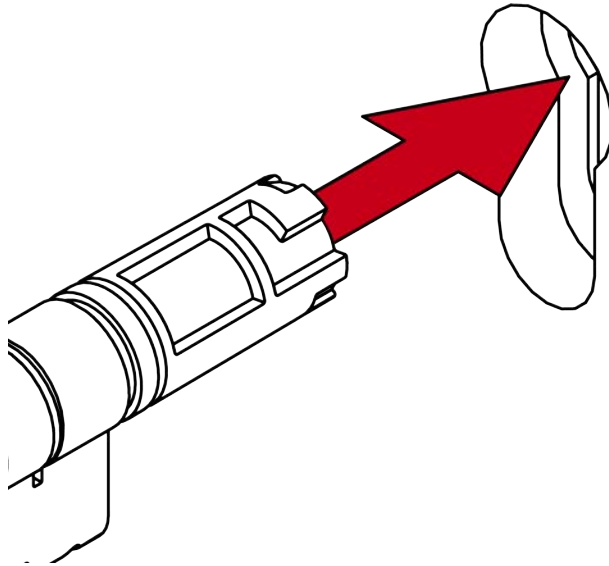

↳ SI Digital Cylinder AX is positioned in the mortise lock.

7. Screw the SI Digital Cylinder AX tight with the face plate screw.

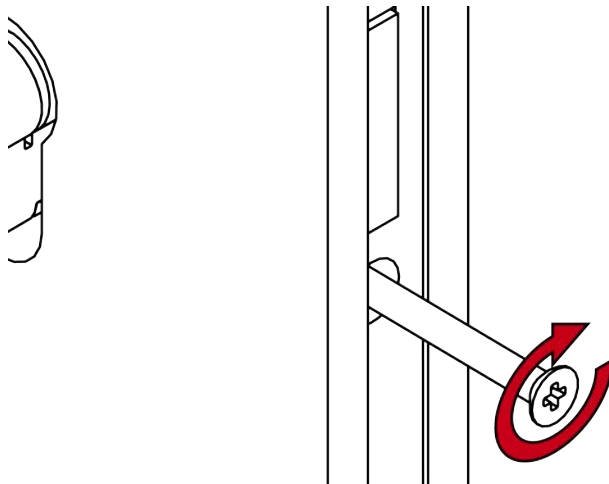

↳ SI Digital Cylinder AX is fixed in the mortise lock.

8. Attach the thumb turn.

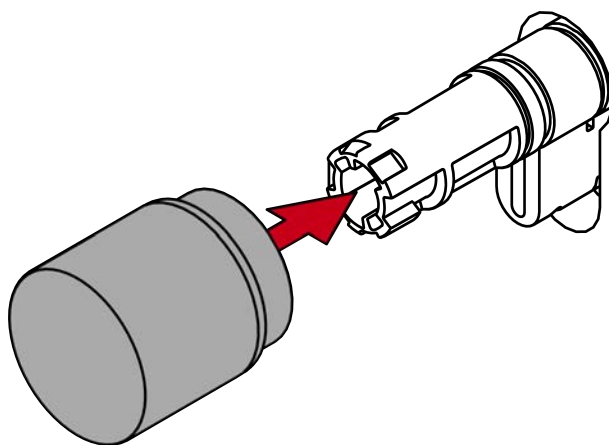

9. Turn the thumb-turn clockwise.

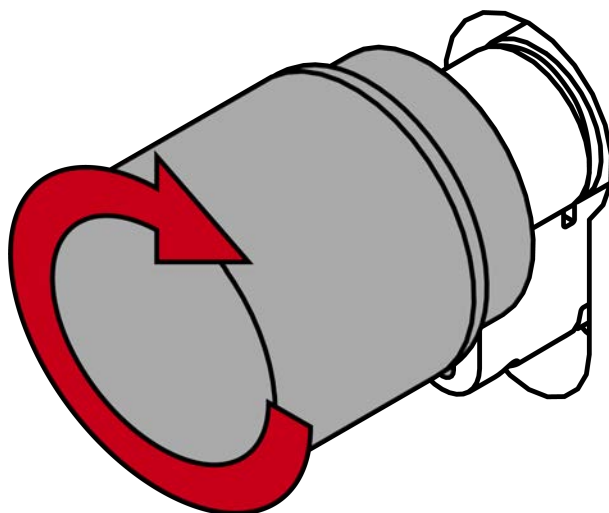

- ↳ The thumb-turn snaps into place with a click.
- ↳ The mechanical thumb-turn is installed.

10. Carry out a functional test (see *Functional test* [▶ 85]).

11. You must also carry out the anti-panic function test on anti-panic cylinders (see AP functional test).

- ↳ SI Digital Cylinder AX is fully installed.

### 9.1.2 Installation with clip-on cover plates

This option allows you to combine the SI Digital Cylinder AX with specific cover plates. Some cover plates are mounted on the cylinder and are located between the thumb-turn and the door. If you want to use such orifices, you have to dismantle both thumb-turn.

- ✓ Special tool available.
- ✓ 1.5 mm hexagonal wrench available.
- ✓ PH2 screwdriver at hand.

1. Align the thumb turn horizontally.

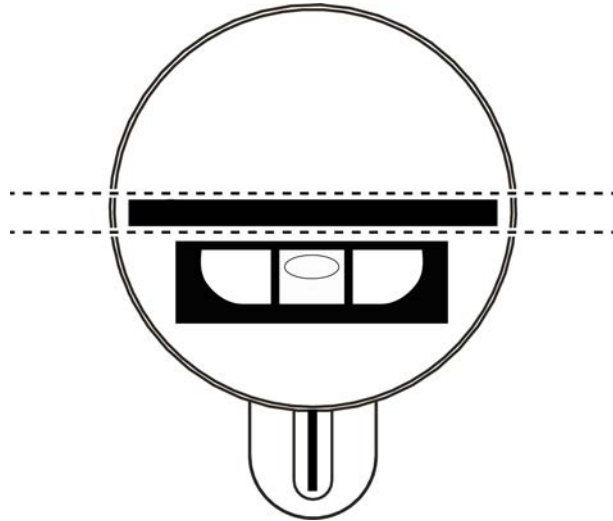

2. Attach the special tool.

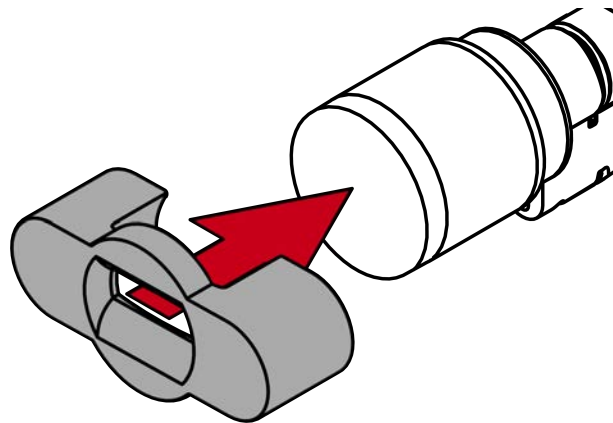

3. Align the special tool so that the logo is parallel to the recess.

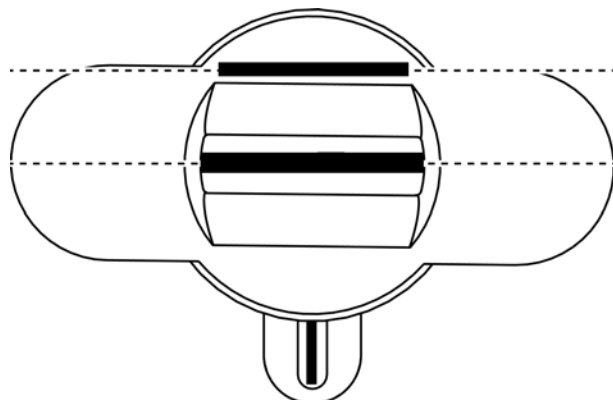



4. At the same time turn the special tool and the thumb-turn counter-clockwise.

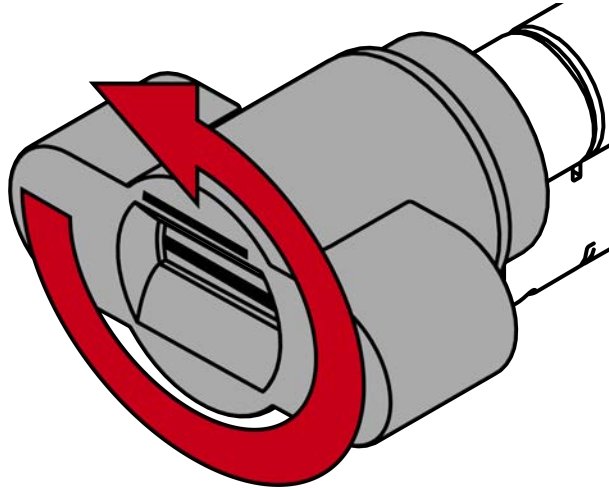

5. Remove the special tool and the thumb-turn at the same time.

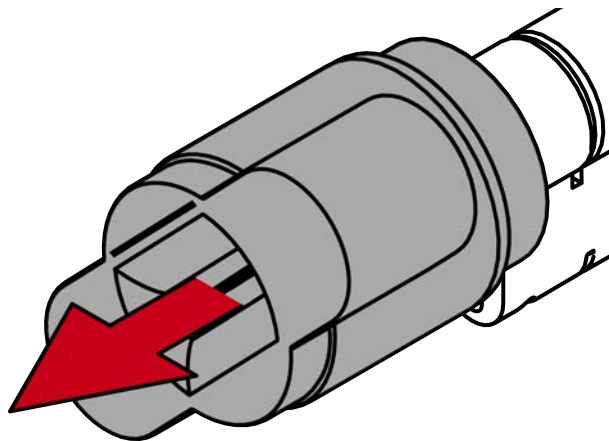

↳ The mechanical thumb-turn is disassembled.

6. Align the thumb turn horizontally.

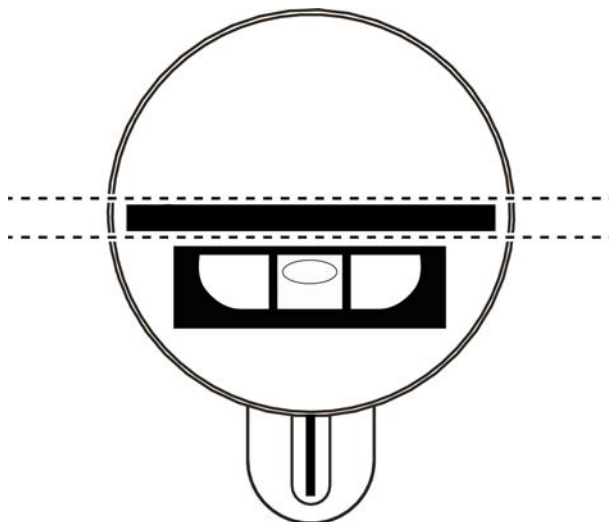

7. Attach the special tool.

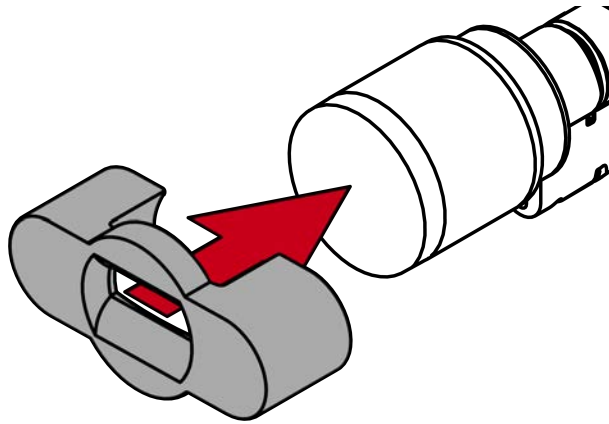

8. Align the special tool so that the logo is parallel to the recess.

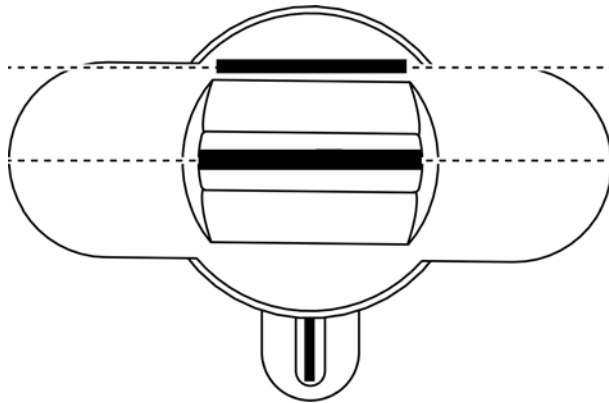

9. Hold the special tool and thumb turn cap firmly at the same time and turn them together 1-2° clockwise first and then counter-clockwise.



#### NOTE

##### Slipping when turning

The surface of the thumb turn cap can be slippery and the cap can be difficult to turn (especially with WP versions, recognizable by the blue cylinder neck ring or the lasered marking on the inner side of the cylinder profile).

- Wear non-slip gloves.

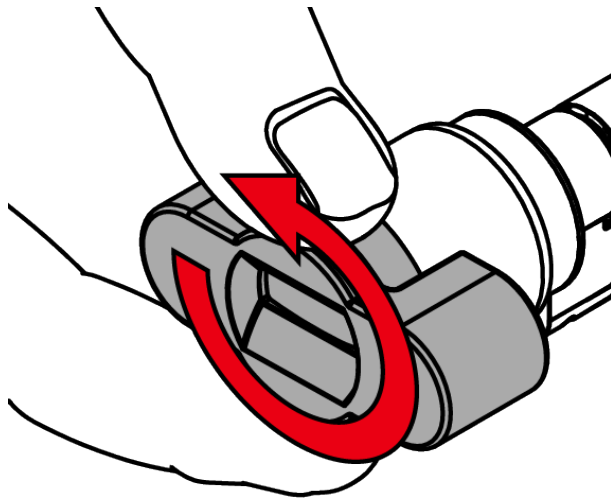

10. Remove the tool and cover.

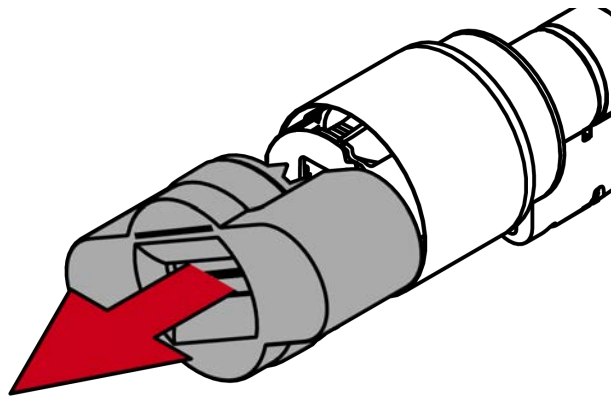

#### NOTE

Use the supplied hexagonal wrench.

The special tool is supplied with a hexagonal wrench.

- Use this hexagonal wrench to mount and dismount the electronic thumb turn.

11. Insert the hexagonal wrench into the hole provided until it stops.

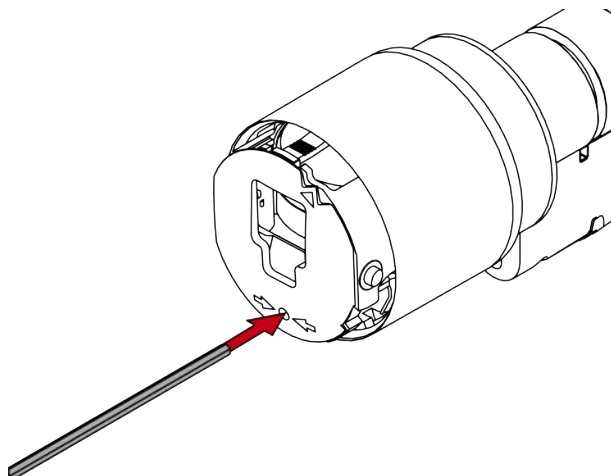

12. Turn the hex wrench 270 degrees counterclockwise.

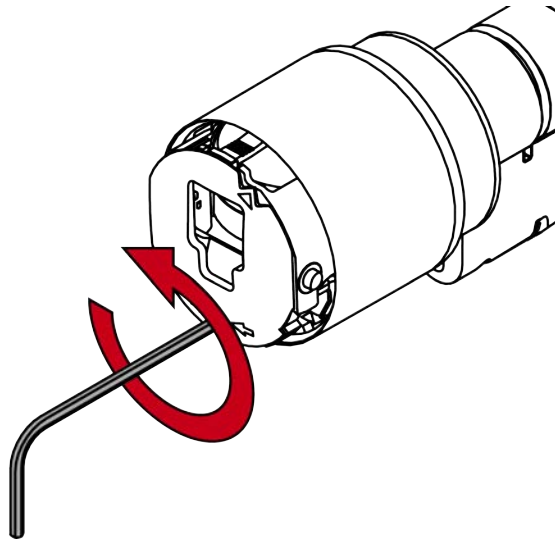

13. Pull out the hexagon wrench again.

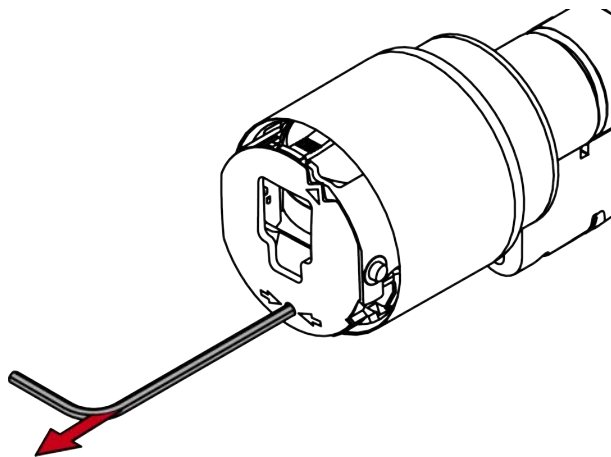

14. Pull off the thumb turn.

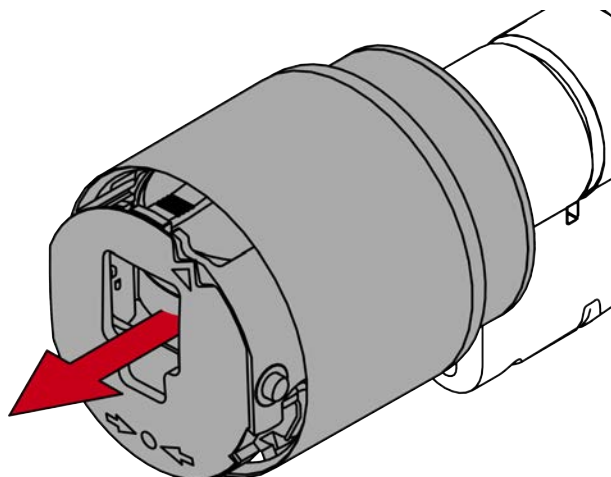

↳ Electronic thumb-turn is disassembled.

15. Insert the SI Digital Cylinder AX into the mortise lock.

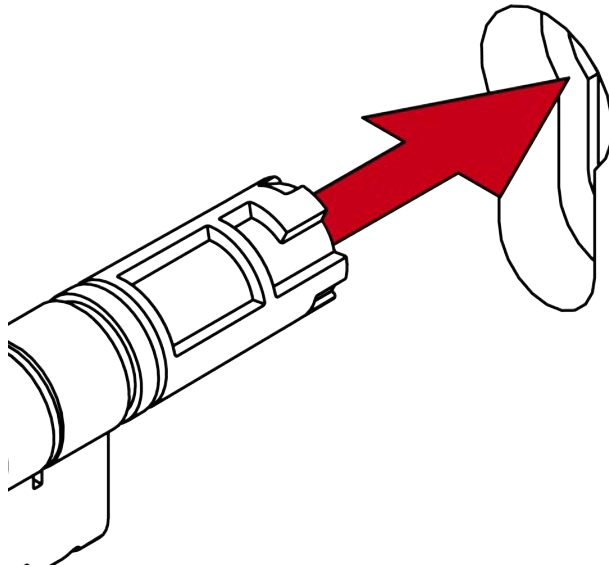

↳ SI Digital Cylinder AX is positioned in the mortise lock.

16. Screw the SI Digital Cylinder AX tight with the face plate screw.

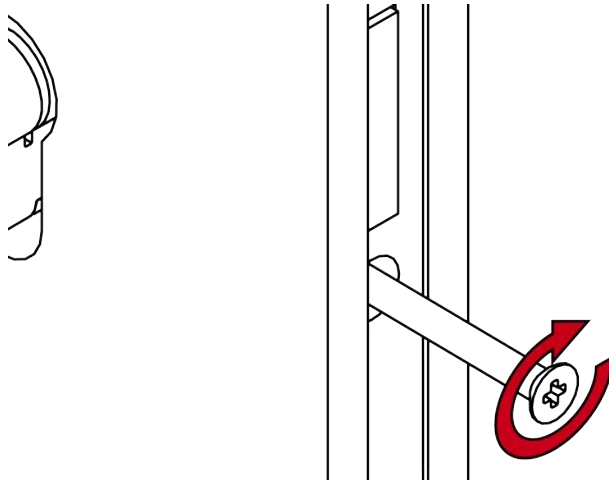

↳ SI Digital Cylinder AX is fixed in the mortise lock.

17. Mount the cover plates if necessary.

18. Align the thumb-turn mount horizontally.

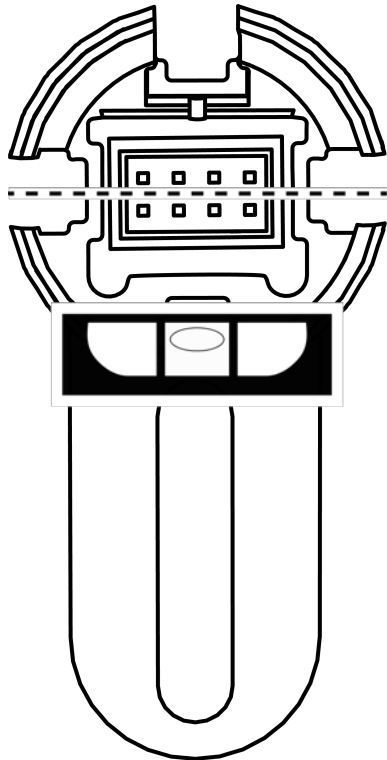

19. Attach the thumb turn.

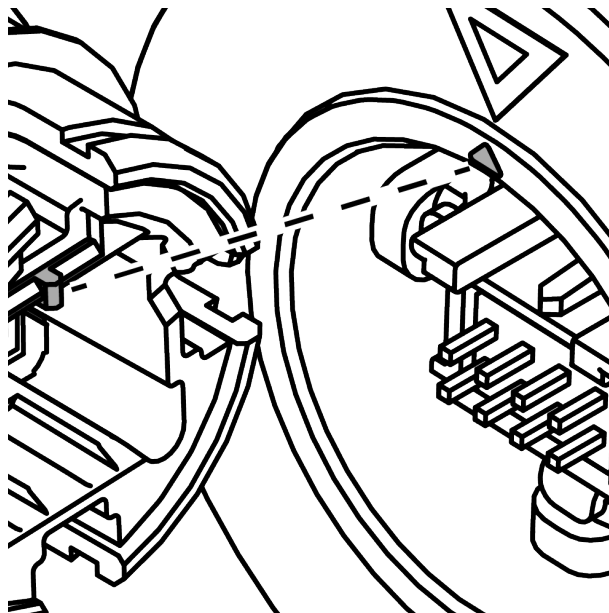

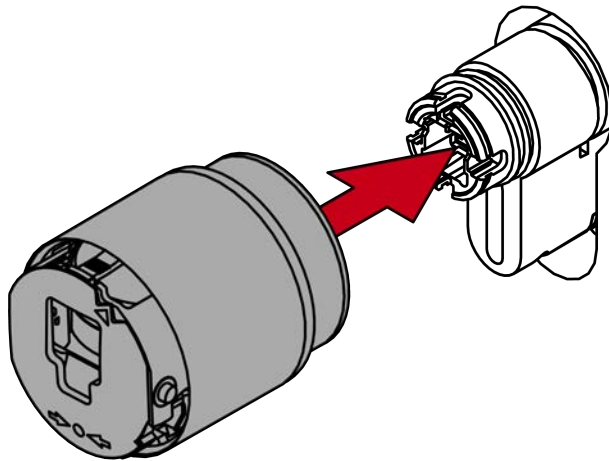

**NOTE**

Use the supplied hexagonal wrench.

The special tool is supplied with a hexagonal wrench.

- Use this hexagonal wrench to mount and dismount the electronic thumb turn.

20. Insert the hexagonal wrench into the hole provided until it stops.

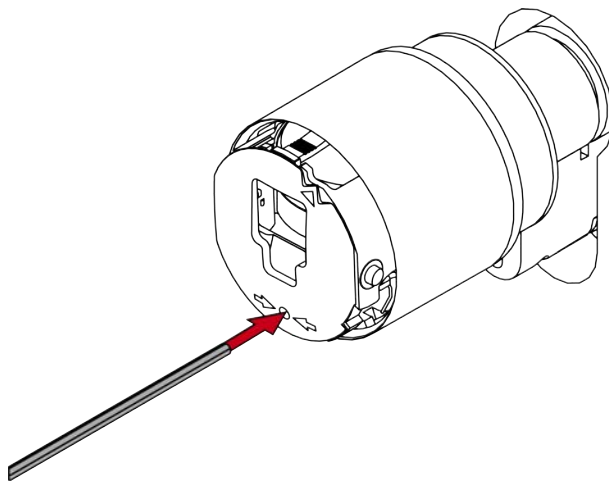

21. Turn the hex key 270 degrees clockwise.

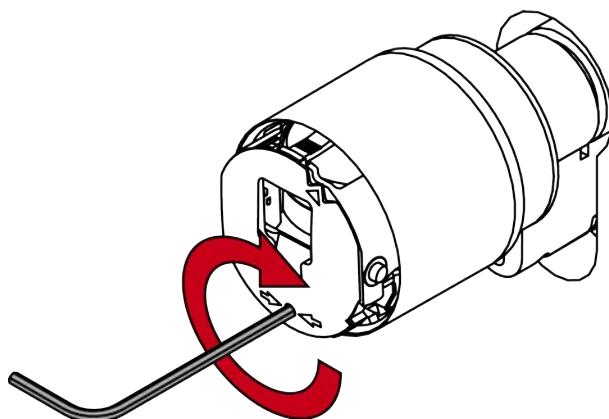

22. Pull out the hexagon wrench again.

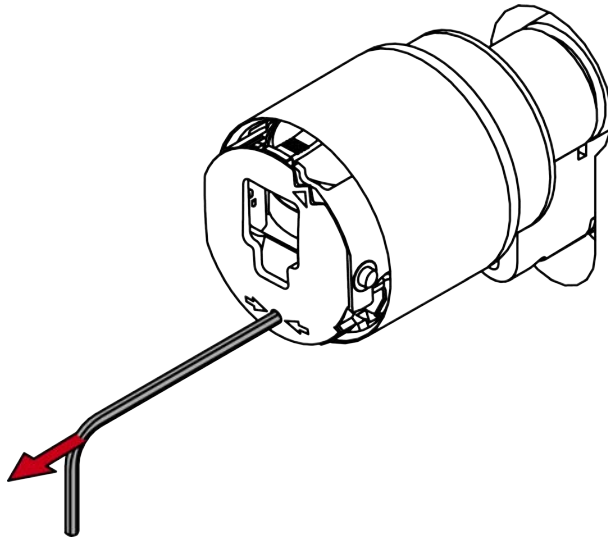

23. Put on the cover.

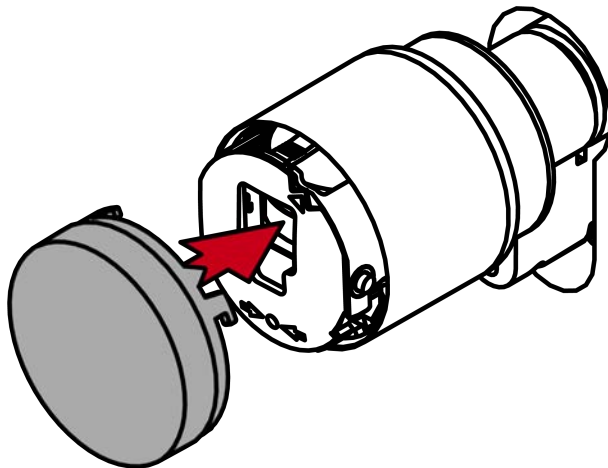
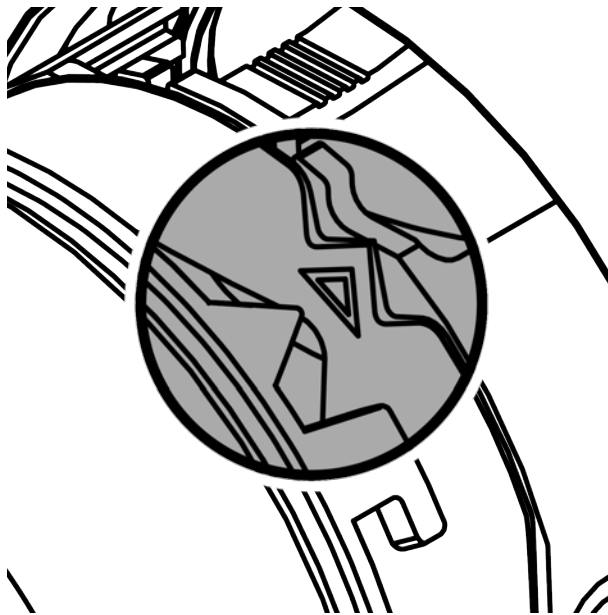



24. Turn the cover clockwise.

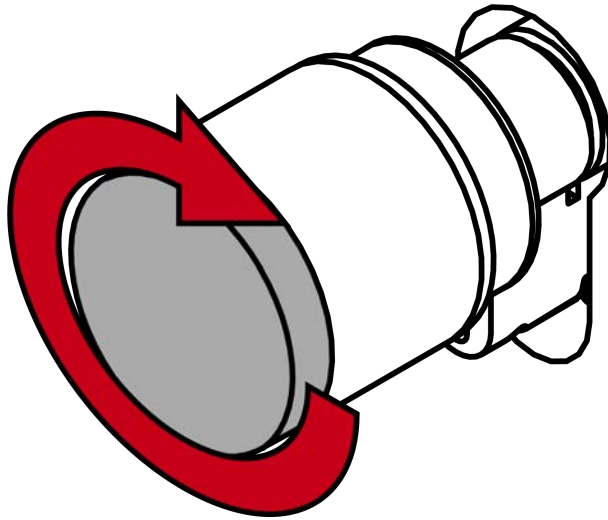

- ↳ The cover snaps into place with one click.
- ↳ The electronic thumb-turn is installed.

25. Attach the thumb turn.

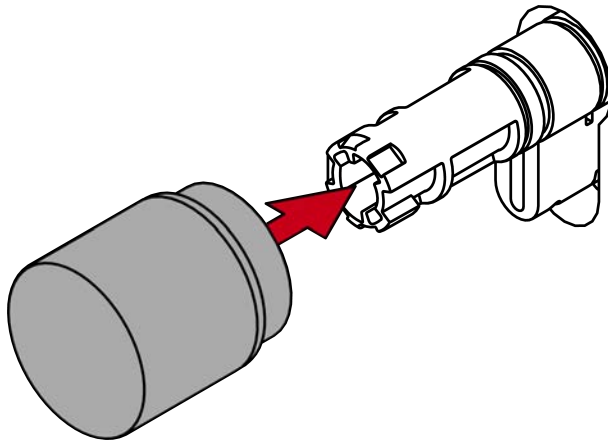

26. Turn the thumb-turn clockwise.

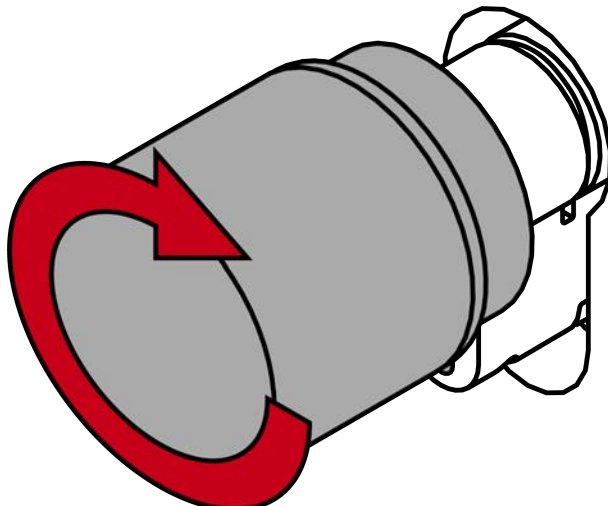

- ↳ The thumb-turn snaps into place with a click.
  - ↳ The mechanical thumb-turn is installed.
27. Carry out a functional test (see *Functional test* [▶ 85]).
28. You must also carry out the anti-panic function test on anti-panic cylinders (see AP functional test).
- ↳ SI Digital Cylinder AX is installed with clip-on cover plates.

## 9.2 Freely-rotating cylinder (FD; reader on both sides)

### 9.2.1 Standard installation

- ✓ Special tool available.
  - ✓ 1.5 mm hexagonal wrench available.
  - ✓ PH2 screwdriver at hand.
1. Align the thumb turn horizontally.

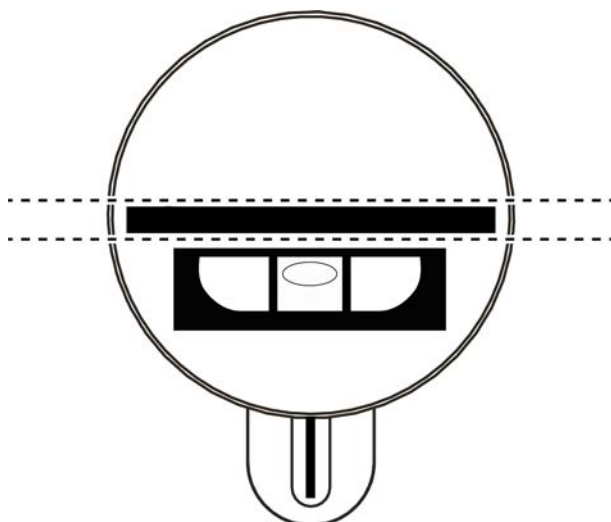

2. Attach the special tool.

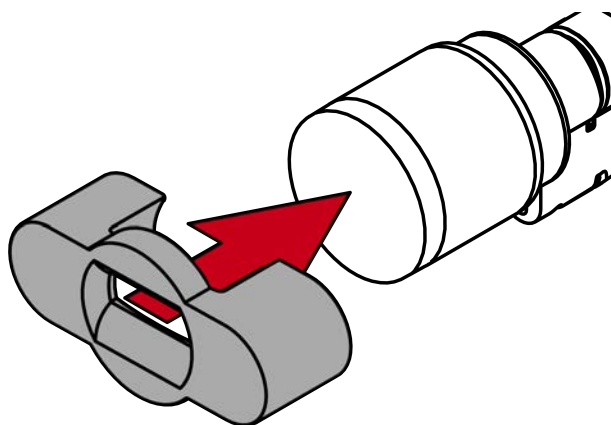

3. Align the special tool so that the logo is parallel to the recess.

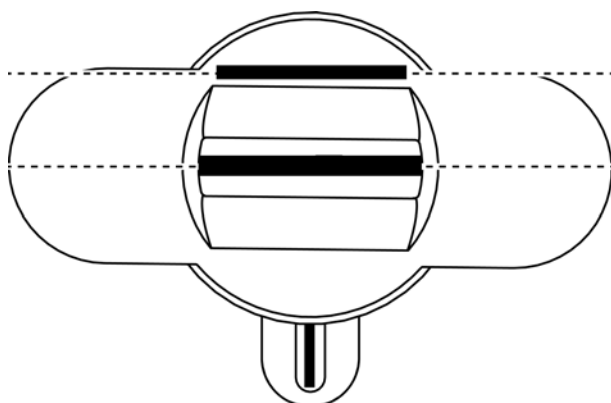

4. Hold the special tool and thumb turn cap firmly at the same time and turn them together 1-2° clockwise first and then counter-clockwise.



#### NOTE

##### Slipping when turning

The surface of the thumb turn cap can be slippery and the cap can be difficult to turn (especially with WP versions, recognizable by the blue cylinder neck ring or the lasered marking on the inner side of the cylinder profile).

- Wear non-slip gloves.

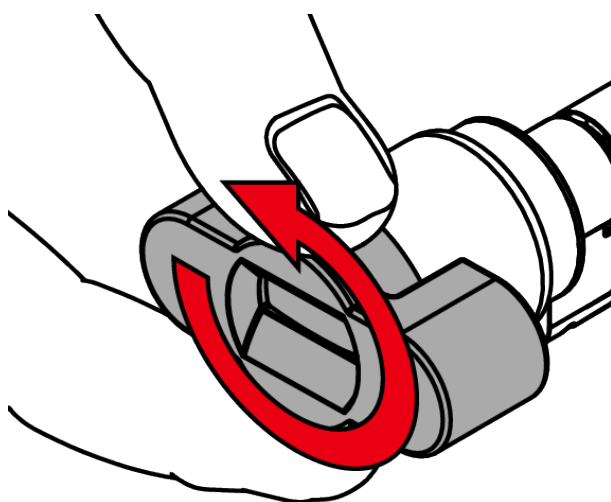

5. Remove the tool and cover.

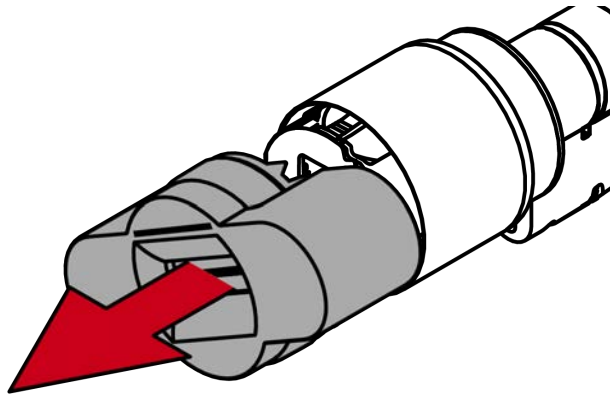

**NOTE**

Use the supplied hexagonal wrench.

The special tool is supplied with a hexagonal wrench.

- Use this hexagonal wrench to mount and dismount the electronic thumb turn.

6. Insert the hexagonal wrench into the hole provided until it stops.

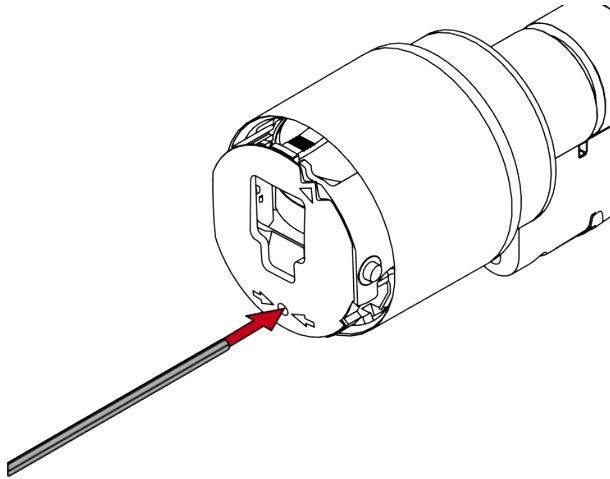

7. Turn the hex wrench 270 degrees counterclockwise.

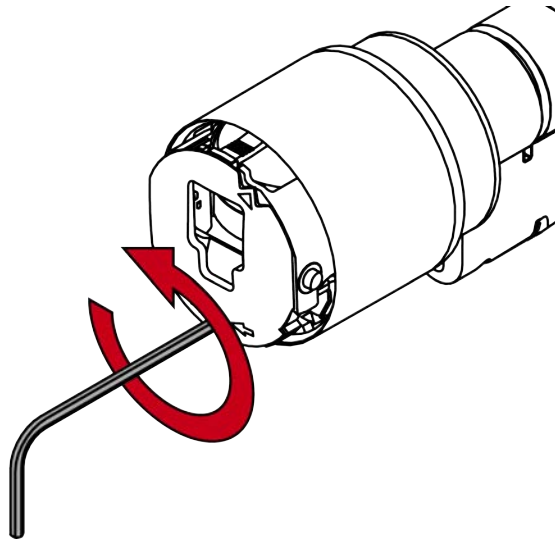

8. Pull out the hexagon wrench again.

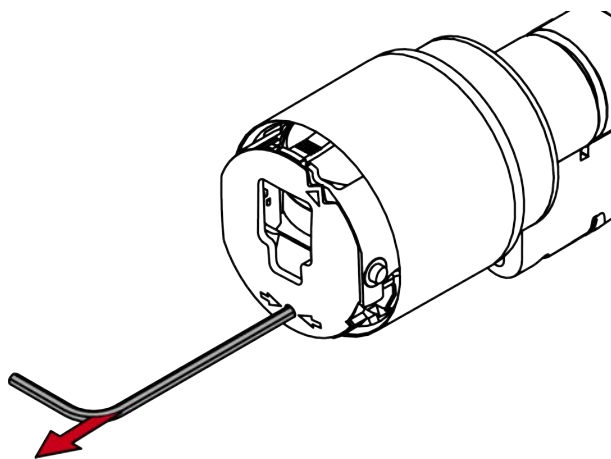

9. Pull off the thumb turn.

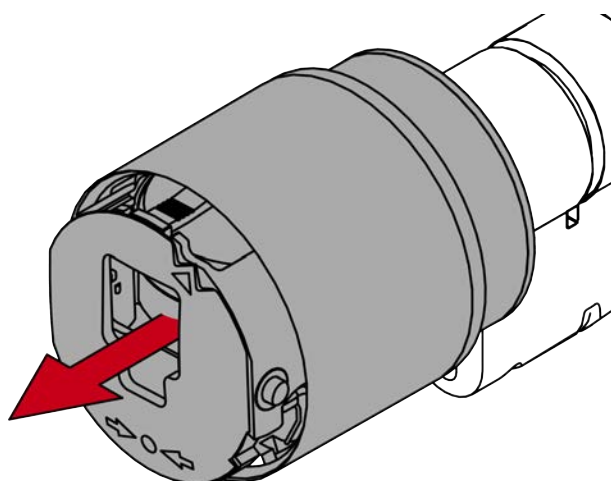

↳ Electronic thumb-turn is disassembled.

10. Insert the SI Digital Cylinder AX into the mortise lock with the side without a thumb-turn facing the lock.

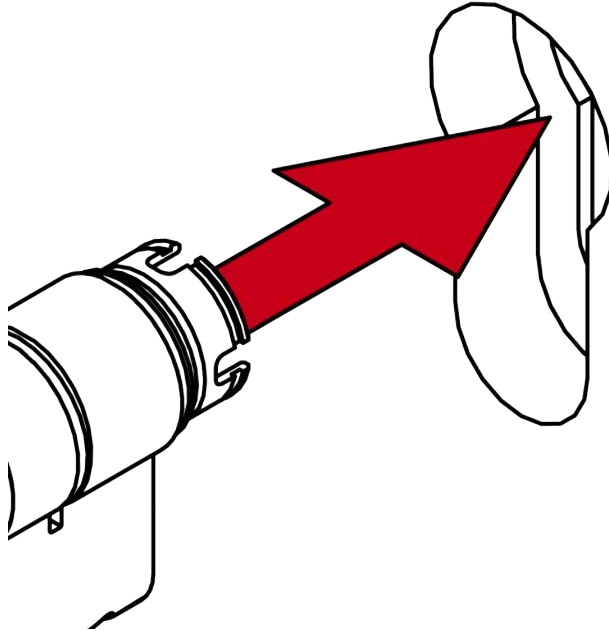

↳ SI Digital Cylinder AX is positioned in the mortise lock.

11. Screw the SI Digital Cylinder AX tight with the face plate screw.

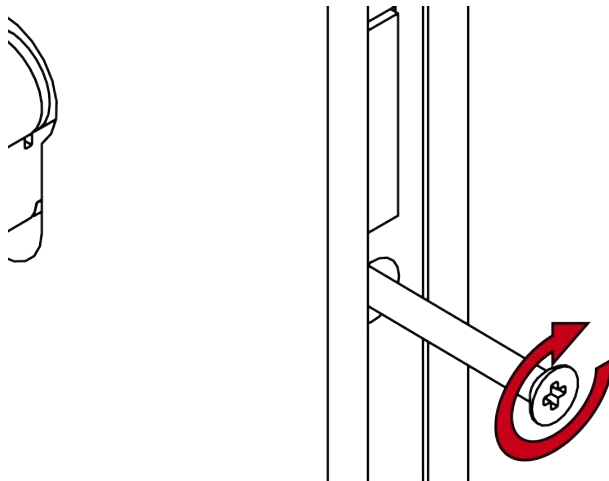

↳ SI Digital Cylinder AX is fixed in the mortise lock.

12. Align the thumb-turn mount horizontally.

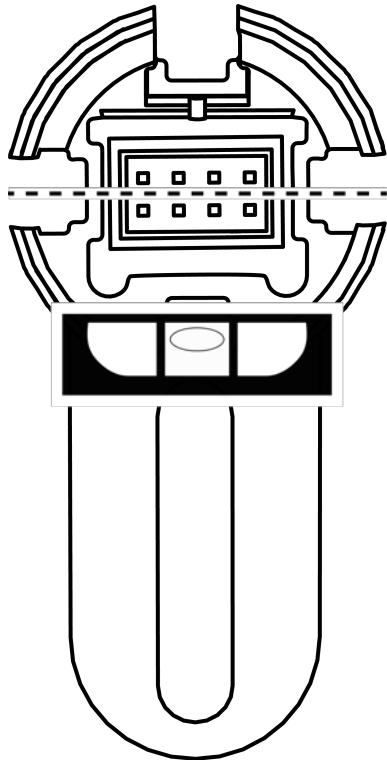

13. Attach the thumb turn.

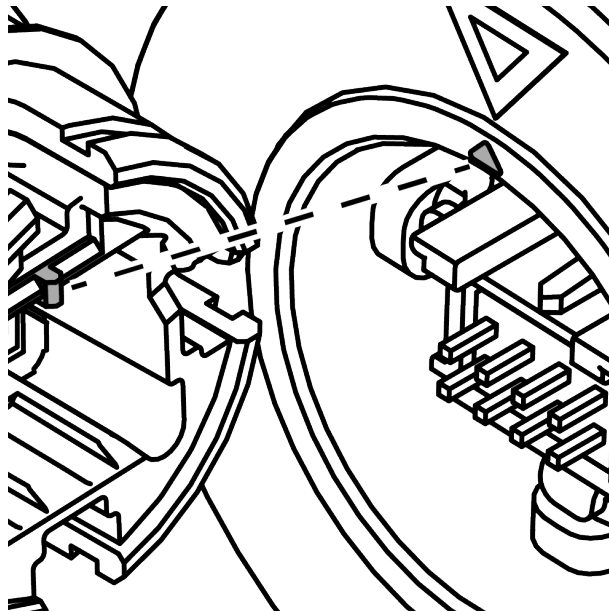

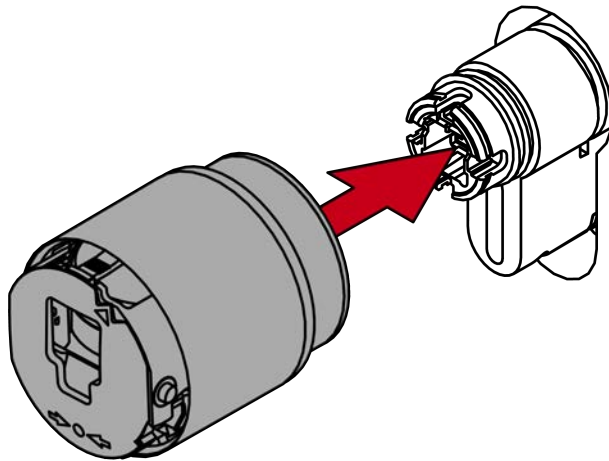

**NOTE**

Use the supplied hexagonal wrench.

The special tool is supplied with a hexagonal wrench.

- Use this hexagonal wrench to mount and dismount the electronic thumb turn.

14. Insert the hexagonal wrench into the hole provided until it stops.

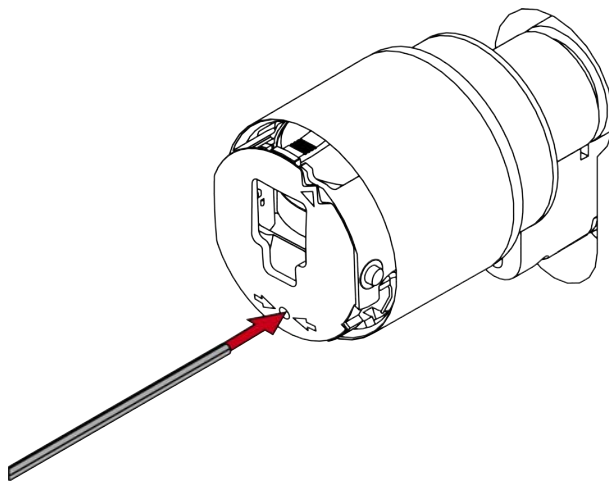

15. Turn the hex key 270 degrees clockwise.

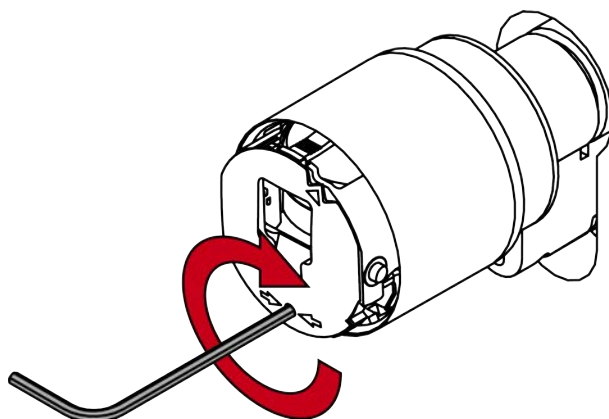



16. Pull out the hexagon wrench again.

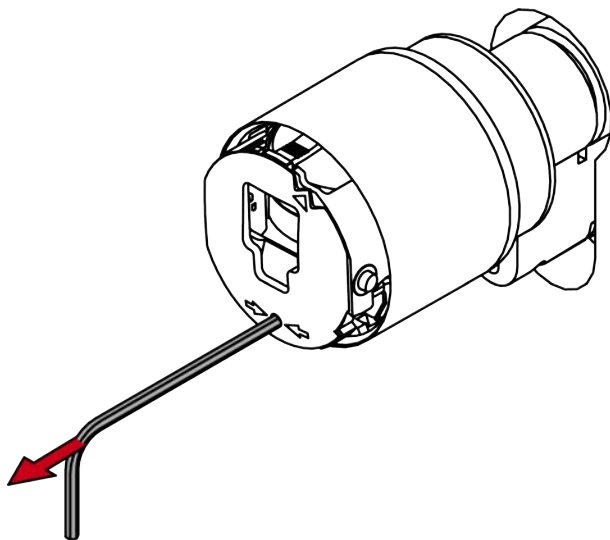

17. Put on the cover.

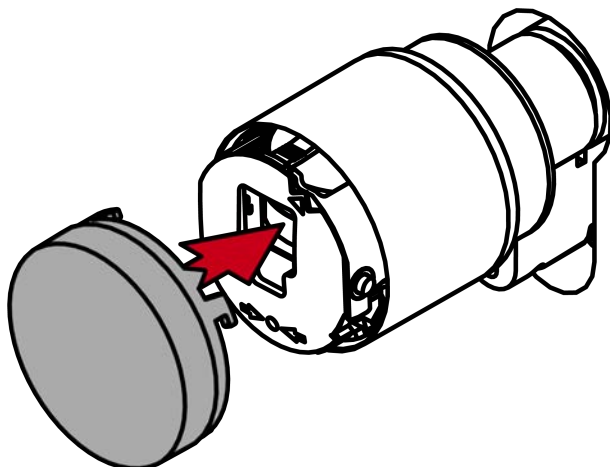
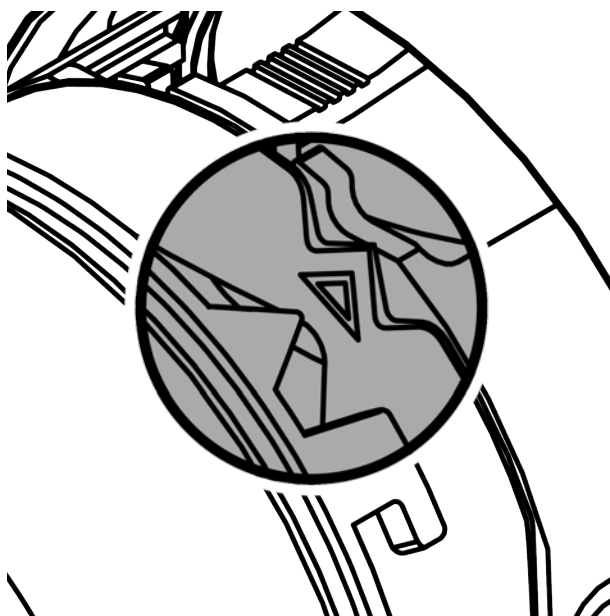

18. Turn the cover clockwise.

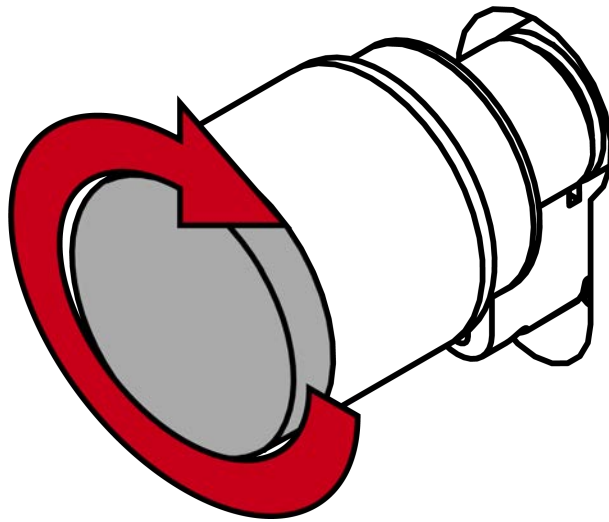

- ↳ The cover snaps into place with one click.
- ↳ The electronic thumb-turn is installed.

19. Carry out a functional test (see *Functional test* [▶ 85]).

20. You must also carry out the anti-panic function test on anti-panic cylinders (see AP functional test).

- ↳ SI Digital Cylinder AX is fully installed.

### 9.2.2 Installation with clip-on cover plates

- ✓ Special tool available.
- ✓ 1.5 mm hexagonal wrench available.
- ✓ PH2 screwdriver at hand.

1. Align the thumb turn horizontally.

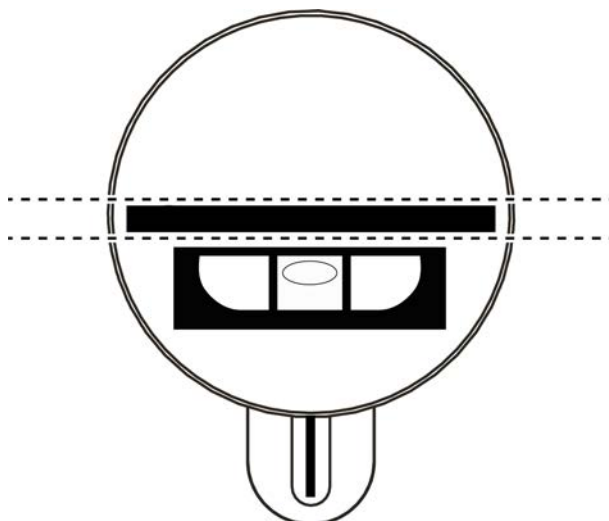

2. Attach the special tool.

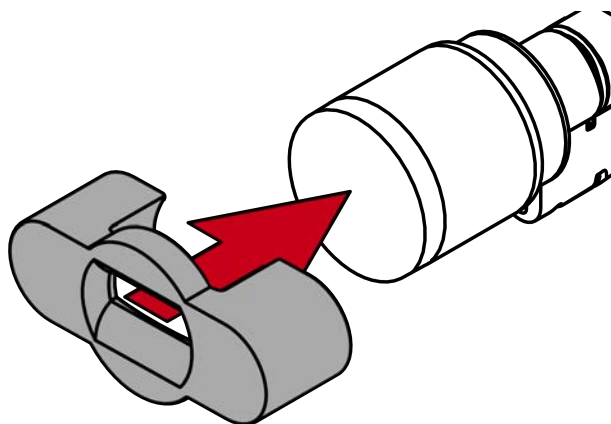

3. Align the special tool so that the logo is parallel to the recess.

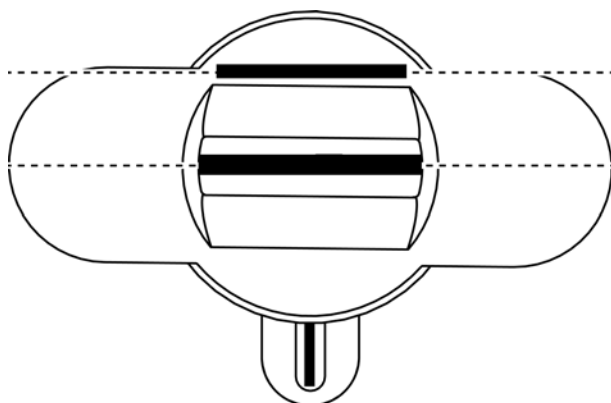

4. Hold the special tool and thumb turn cap firmly at the same time and turn them together 1-2° clockwise first and then counter-clockwise.



#### NOTE

##### Slipping when turning

The surface of the thumb turn cap can be slippery and the cap can be difficult to turn (especially with WP versions, recognizable by the blue cylinder neck ring or the lasered marking on the inner side of the cylinder profile).

- Wear non-slip gloves.

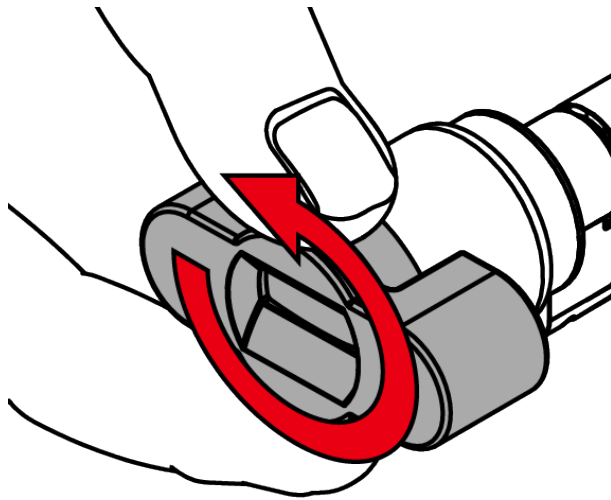

5. Remove the tool and cover.

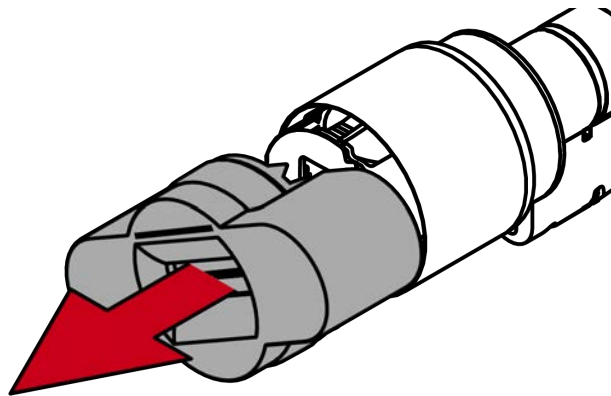

#### NOTE

Use the supplied hexagonal wrench.

The special tool is supplied with a hexagonal wrench.

- Use this hexagonal wrench to mount and dismount the electronic thumb turn.

6. Insert the hexagonal wrench into the hole provided until it stops.

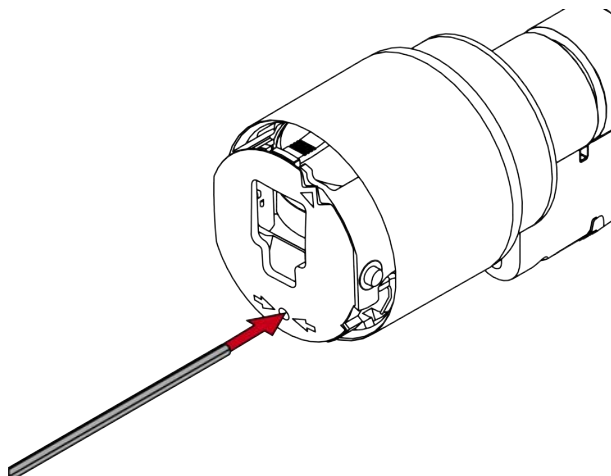

7. Turn the hex wrench 270 degrees counterclockwise.

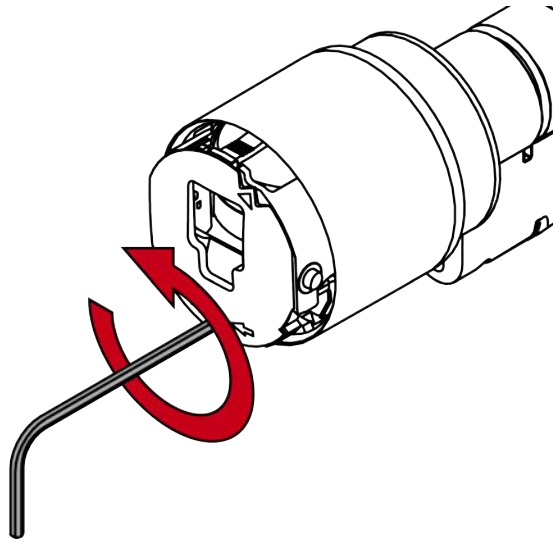

8. Pull out the hexagon wrench again.

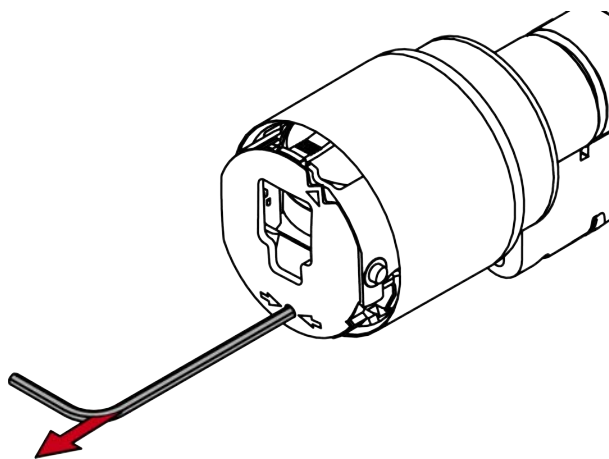

9. Pull off the thumb turn.

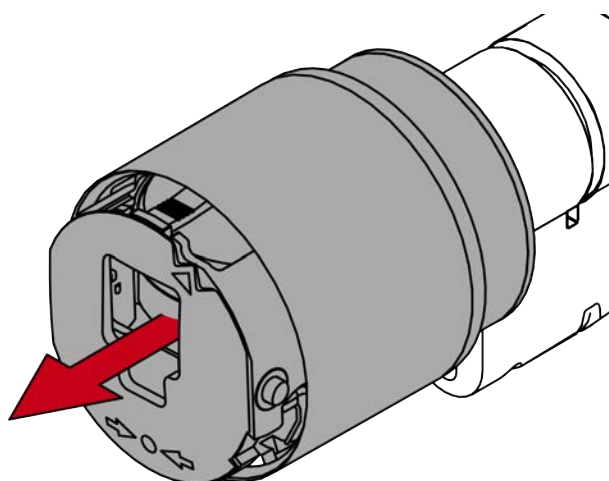

↳ Electronic thumb-turn is disassembled.

10. Remove the other thumb-turn as well.

11. Insert the SI Digital Cylinder AX into the mortise lock.

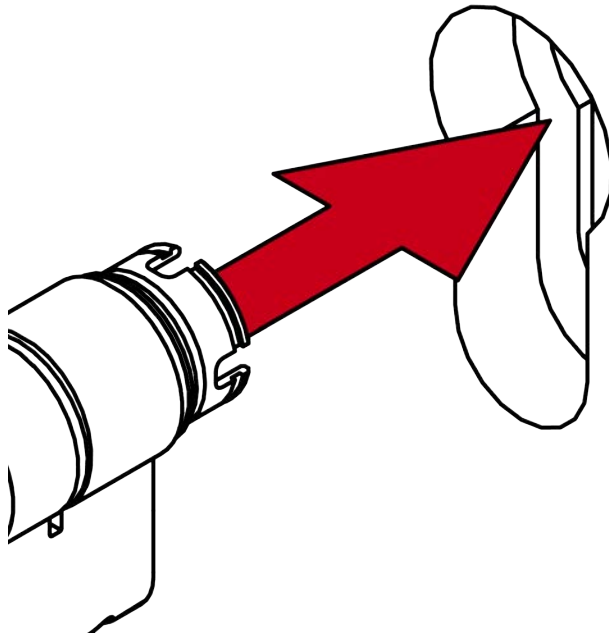

↳ SI Digital Cylinder AX is positioned in the mortise lock.

12. Screw the SI Digital Cylinder AX tight with the face plate screw.

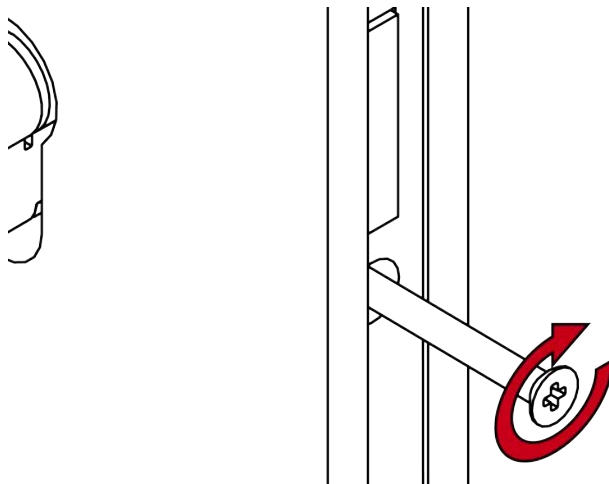

13. Mount the cover plates if necessary.

14. Align the thumb-turn mount horizontally.

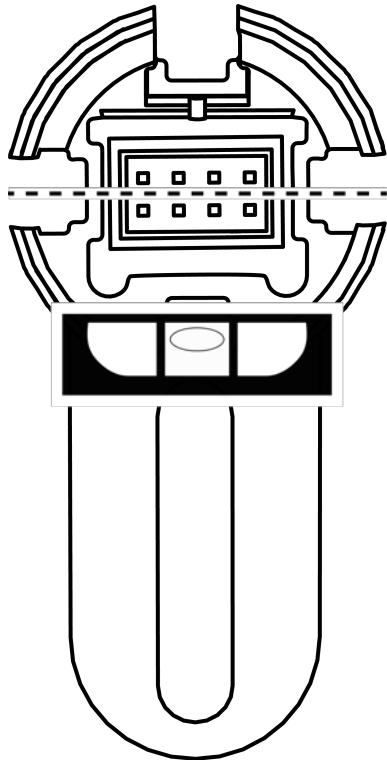

15. Attach the thumb turn.

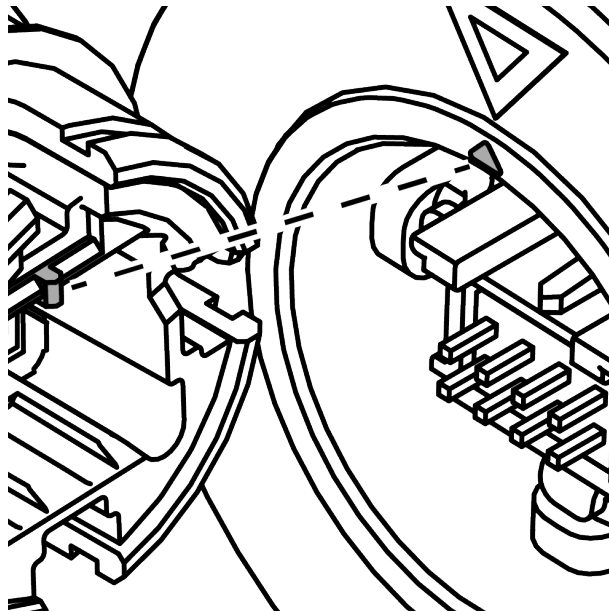

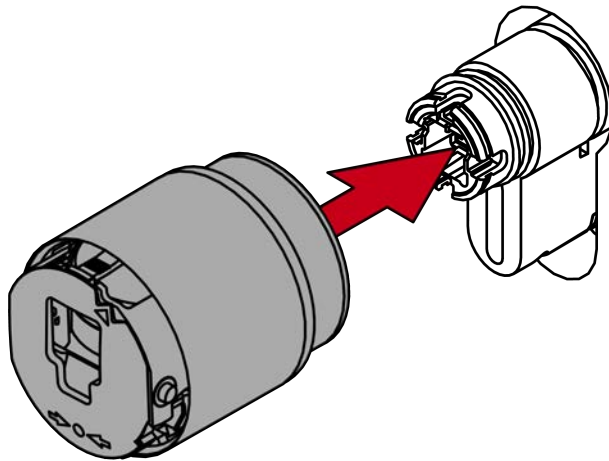

**NOTE**

Use the supplied hexagonal wrench.

The special tool is supplied with a hexagonal wrench.

- Use this hexagonal wrench to mount and dismount the electronic thumb turn.

16. Insert the hexagonal wrench into the hole provided until it stops.

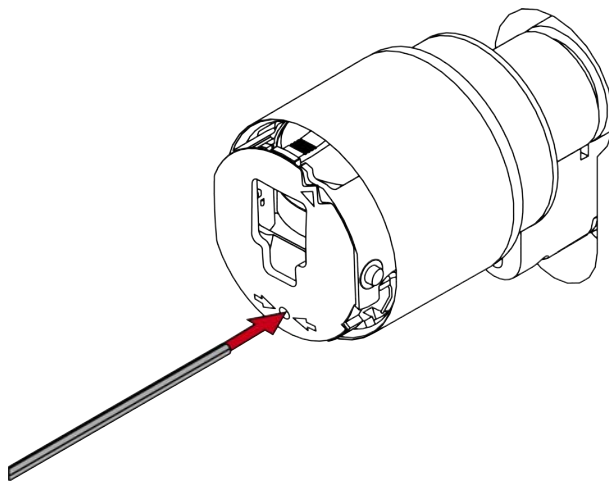

17. Turn the hex wrench 270 degrees counterclockwise.

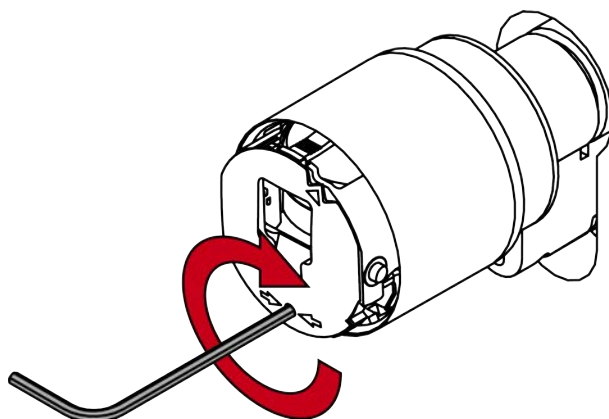



18. Pull out the hexagon wrench again.

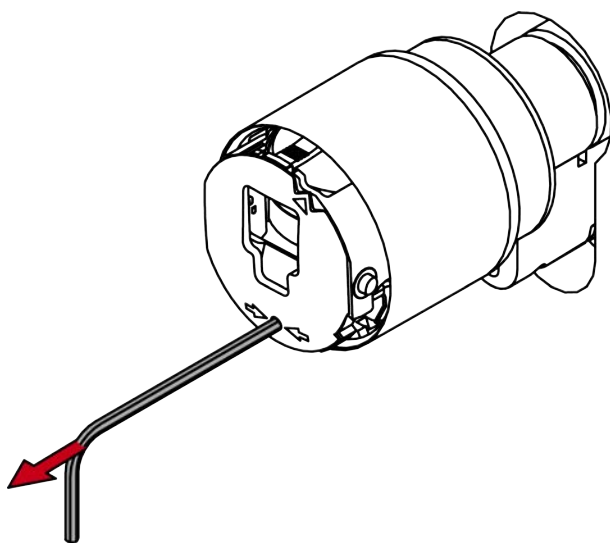

19. Put on the cover.

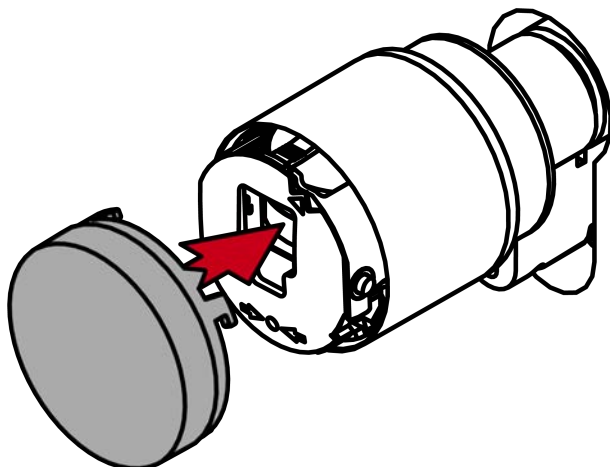
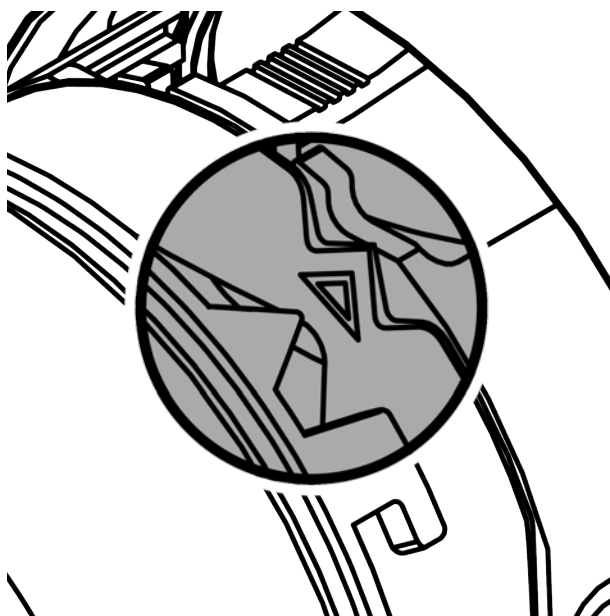

20. Turn the cover clockwise.

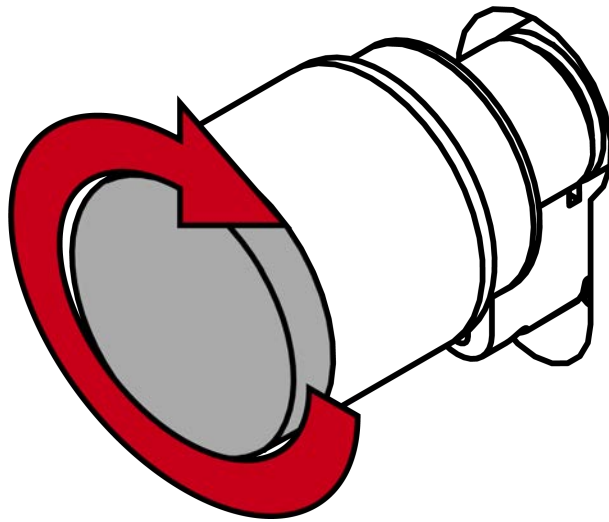

- ↳ The cover snaps into place with one click.
  - ↳ The electronic thumb-turn is installed.
21. Install the other electronic thumb-turn in the same way.
22. Carry out a functional test (see *Functional test* [▶ 85]).
23. You must also carry out the anti-panic function test on anti-panic cylinders (see AP functional test).
- ↳ SI Digital Cylinder AX is installed with clip-on cover plates.

### 9.3 Half cylinder (HZ, reader on one side)

#### 9.3.1 Standard installation

✓ PH2 screwdriver at hand.

1. Insert the SI Digital Cylinder AX into the mortise lock with the side without a thumb-turn facing the lock.

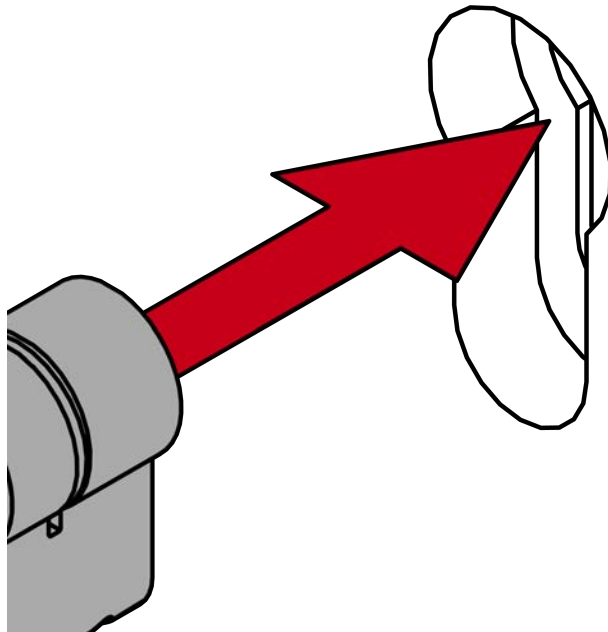

↳ SI Digital Cylinder AX is positioned in the mortise lock.

2. Screw the SI Digital Cylinder AX tight with the face plate screw.

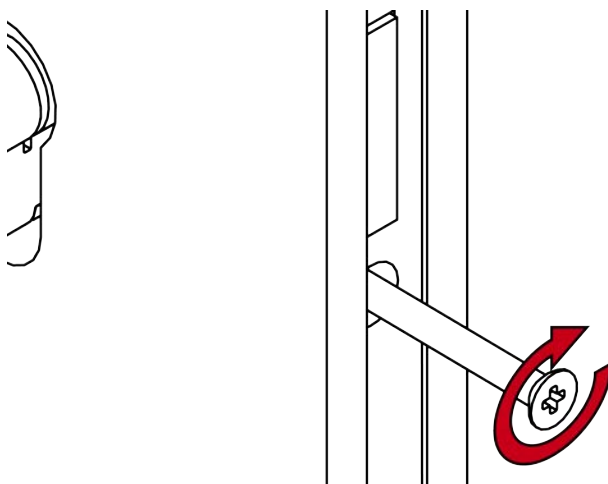

↳ SI Digital Cylinder AX is fixed in the mortise lock.

↳ SI Digital Cylinder AX is fully installed.

### 9.3.2 Installation with clip-on cover plate

- ✓ Special tool available.
- ✓ 1.5 mm hexagonal wrench available.
- ✓ PH2 screwdriver at hand.

1. Align the thumb turn horizontally.

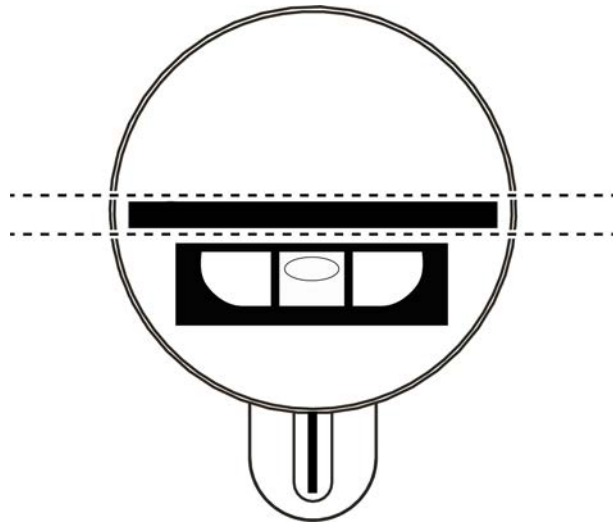

2. Attach the special tool.

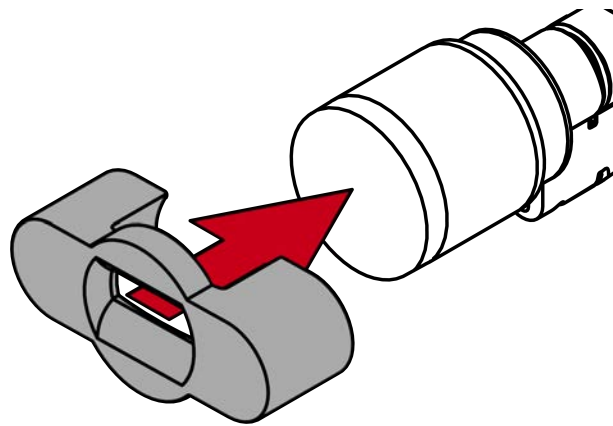

3. Align the special tool so that the logo is parallel to the recess.

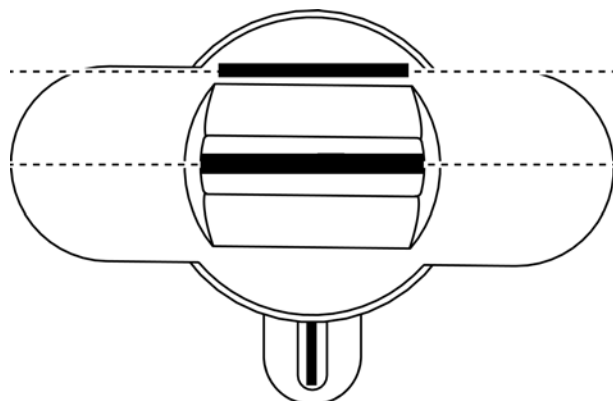

4. Hold the special tool and thumb turn cap firmly at the same time and turn them together 1-2° clockwise first and then counter-clockwise.



**NOTE**

**Slipping when turning**

The surface of the thumb turn cap can be slippery and the cap can be difficult to turn (especially with WP versions, recognizable by the blue cylinder neck ring or the lasered marking on the inner side of the cylinder profile).

- Wear non-slip gloves.

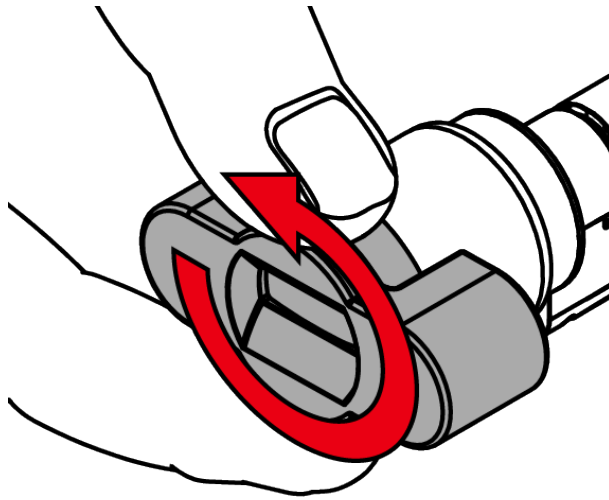

5. Remove the tool and cover.

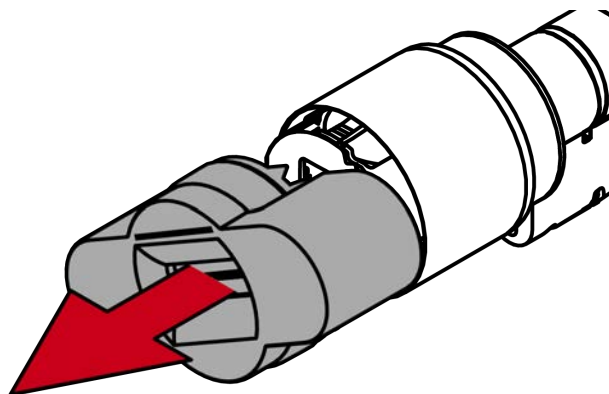

**NOTE**

**Use the supplied hexagonal wrench.**

The special tool is supplied with a hexagonal wrench.

- Use this hexagonal wrench to mount and dismount the electronic thumb turn.

6. Insert the hexagonal wrench into the hole provided until it stops.

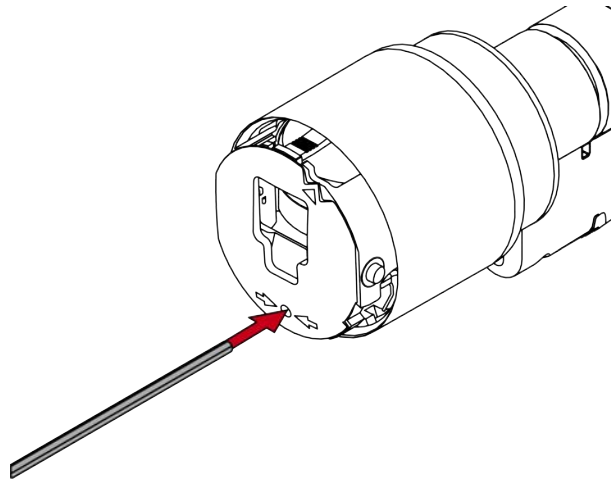

7. Turn the hex wrench 270 degrees counterclockwise.

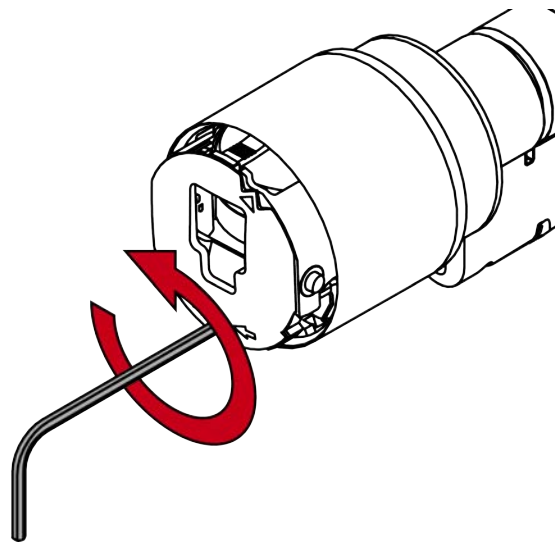

8. Pull out the hexagon wrench again.

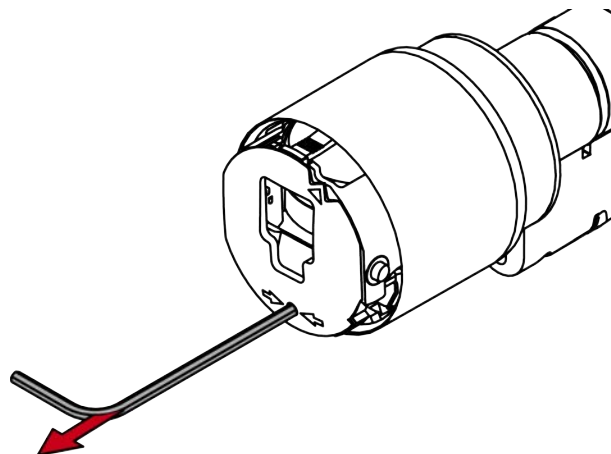

9. Pull off the thumb turn.

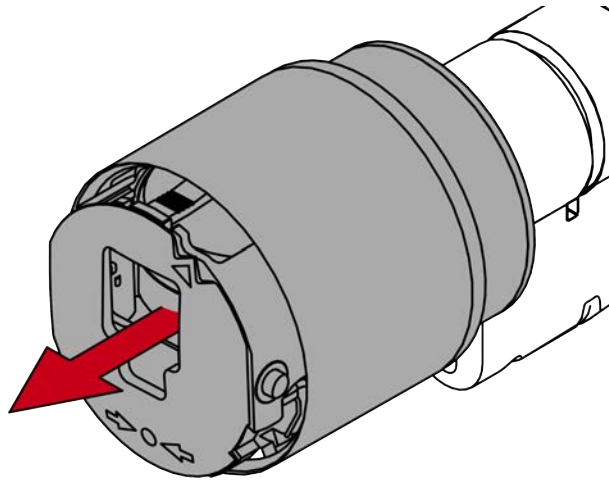

↳ Electronic thumb-turn is disassembled.

10. Insert the SI Digital Cylinder AX into the mortise lock.

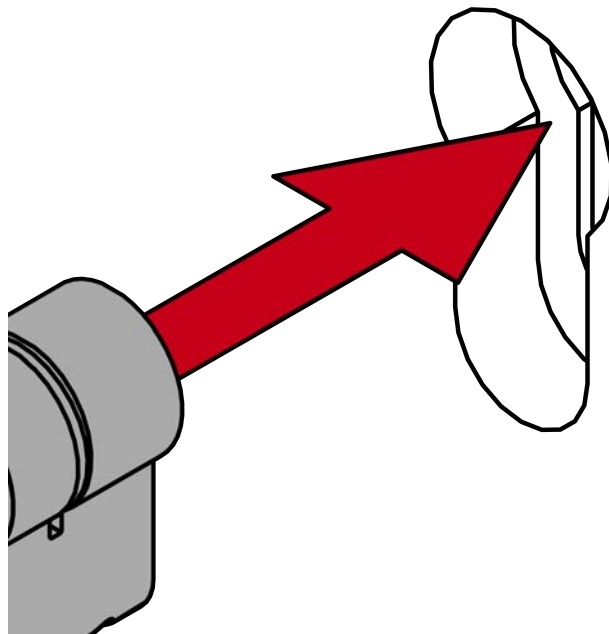

11. Screw the SI Digital Cylinder AX tight with the face plate screw.

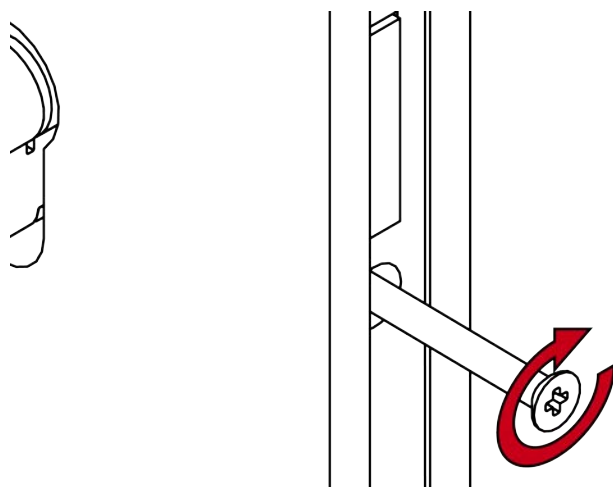

12. Mount the cover plates if necessary.
13. Align the thumb-turn mount horizontally.

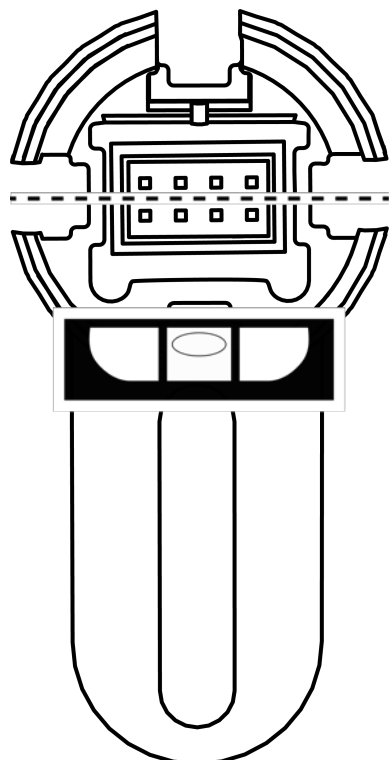



14. Attach the thumb turn.

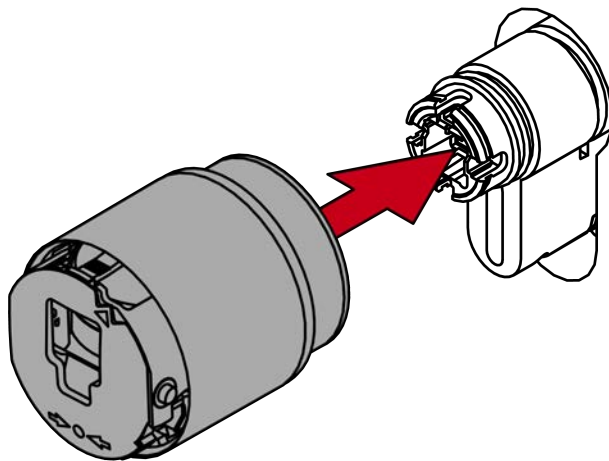
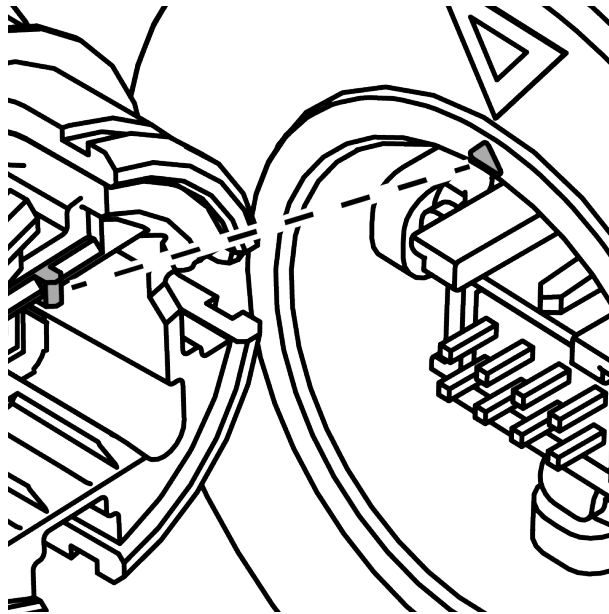

#### NOTE

Use the supplied hexagonal wrench.

The special tool is supplied with a hexagonal wrench.

- Use this hexagonal wrench to mount and dismount the electronic thumb turn.

15. Insert the hexagonal wrench into the hole provided until it stops.

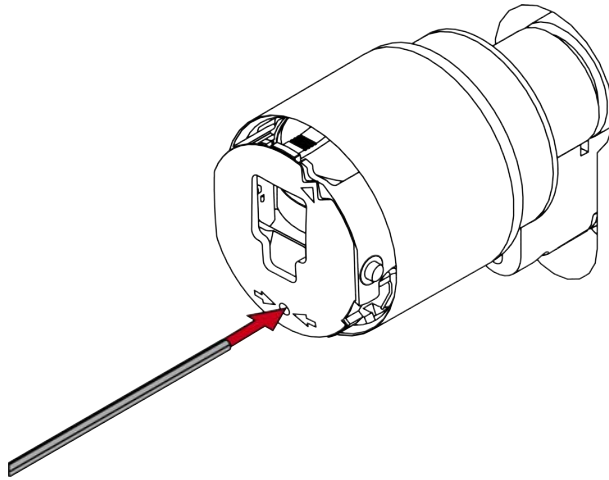

16. Turn the hex wrench 270 degrees counterclockwise.

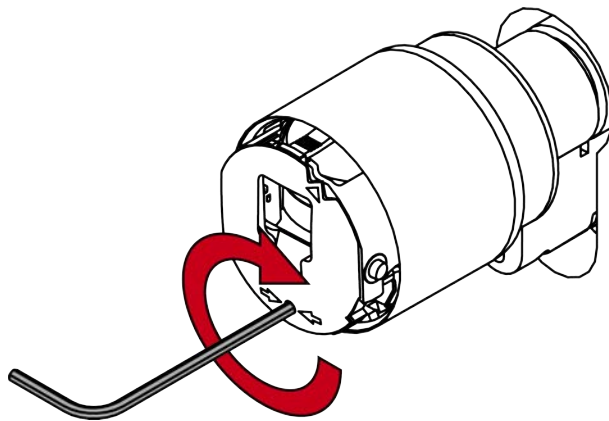

17. Pull out the hexagon wrench again.

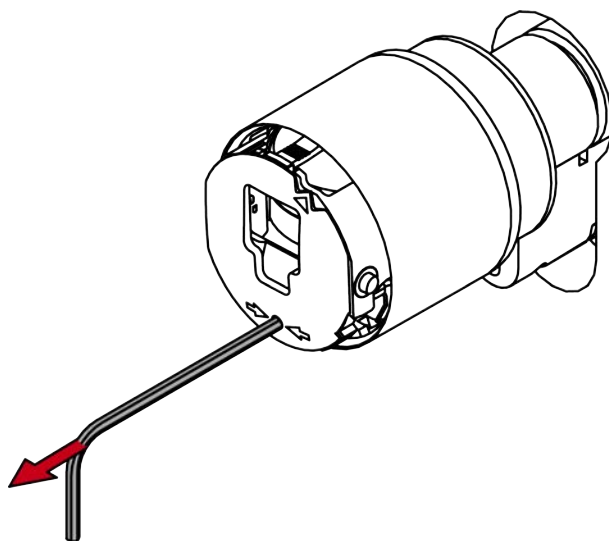

18. Put on the cover.

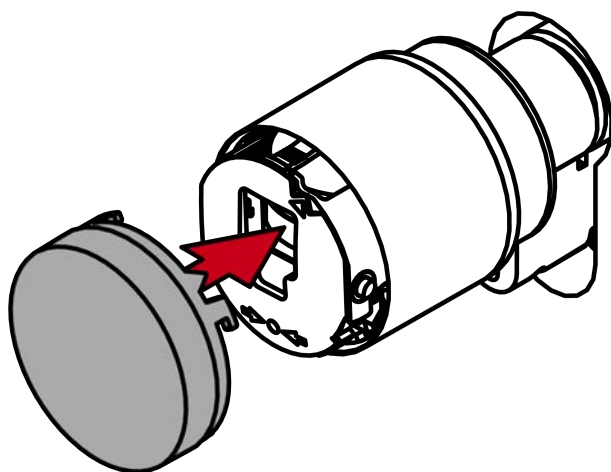
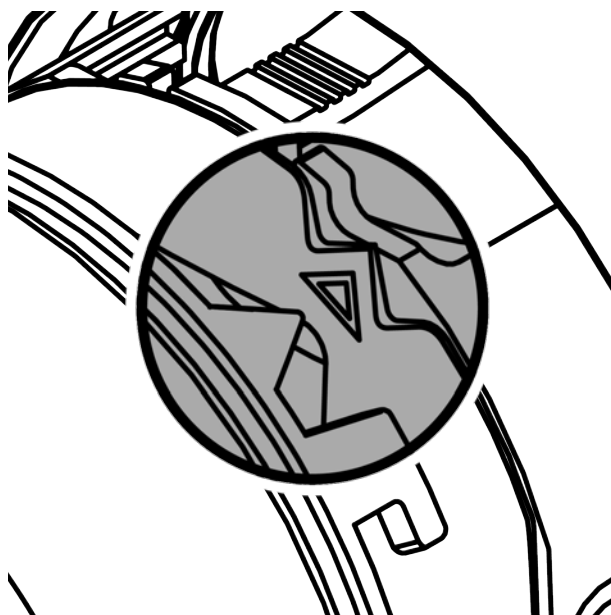

19. Turn the cover clockwise.

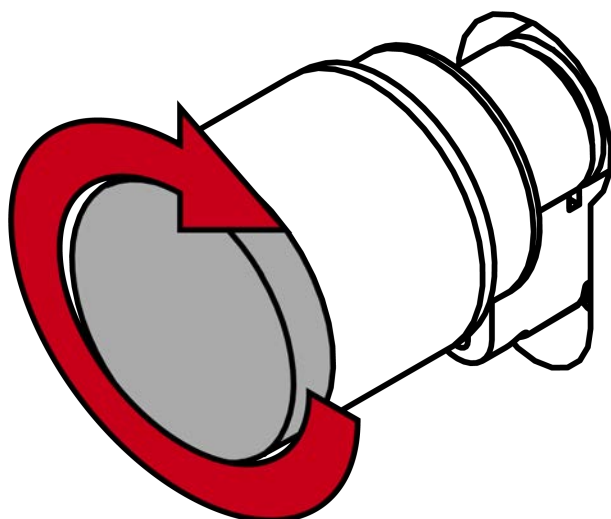

↳ The cover snaps into place with one click.

- ↳ The electronic thumb-turn is installed.
- 20. Carry out a functional test (see *Functional test* [▶ 85]).
- 21. You must also carry out the anti-panic function test on anti-panic cylinders (see AP functional test).
- ↳ SI Digital Cylinder AX is installed with clip-on cover plate.

## 9.4 Scandinavian oval/round (SO/RS)



### NOTE

#### Conditions for SSF approval

The approval of the SI Digital Cylinder AX is subject to the following conditions:

1. Mount the SSF-approved SI Digital Cylinder AX together with a reinforcement device according to SSF 1096 / SSF 3522.
2. Mount the SSF-approved SI Digital Cylinder AX with screws that have an SSF 1091 approved screw drive.

### 9.4.1 Installation

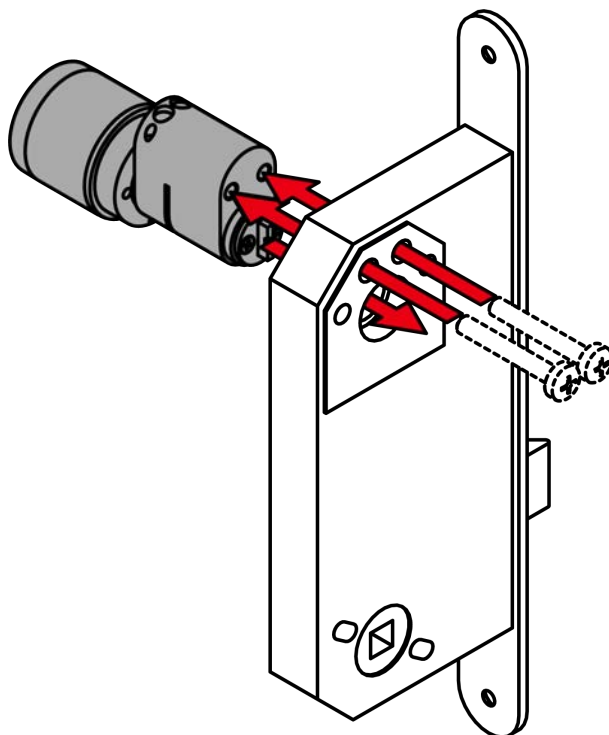

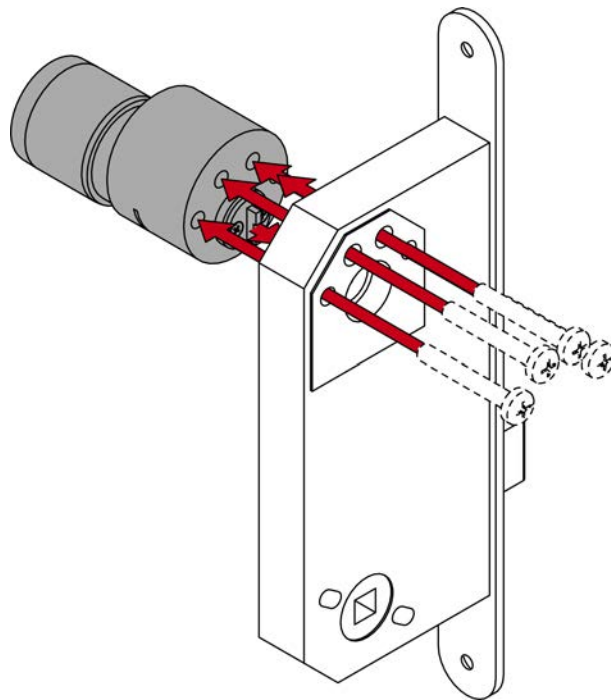

### IMPORTANT

#### Unauthorised access by drilling on the inside

The outside of the SI Digital Cylinder AX is equipped with drilling protection on the outside, depending on the version.

- If you find a mark on the inside (*IN*) of the cylinder body, mount the SI Digital Cylinder AX so that this side is in a protected area.

✓ Rosettes may already be fitted.

1. Insert the SI Digital Cylinder AX with the cam into the retainer of the mortise lock.
  2. Screw the SI Digital Cylinder AX tight.
  3. If necessary, install other fittings.
- ↳ SI Digital Cylinder AX installed.

### 9.5 Installing the Glass Door Cylinder AX

- ✓ 1.5 mm hexagonal wrench available.
- ✓ PH2 screwdriver at hand.

1. Undo the grub screw from the inside thumb-turn (SW 1.5 mm).

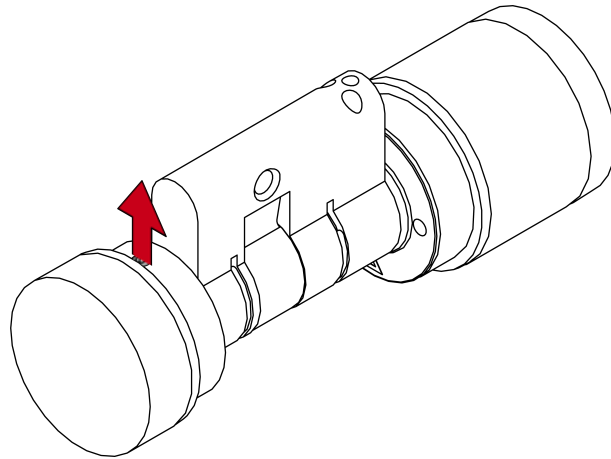

2. Twist the inside thumb-turn off anti-clockwise.

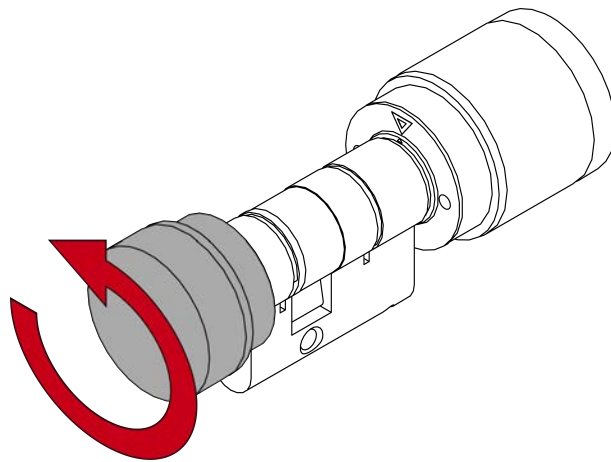

3. Insert the SI Digital Glass Door Cylinder AX into the door.

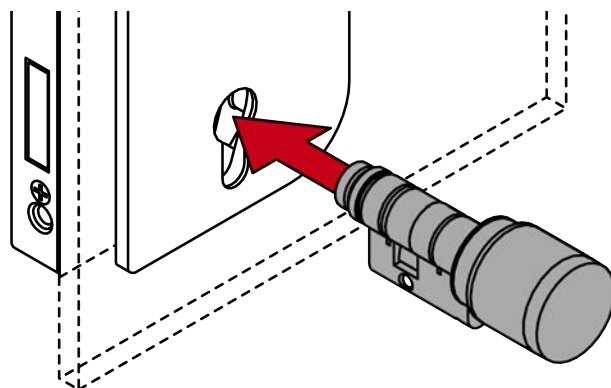

4. Secure the SI Digital Glass Door Cylinder AX firmly into place with the fastening screw (PH2).

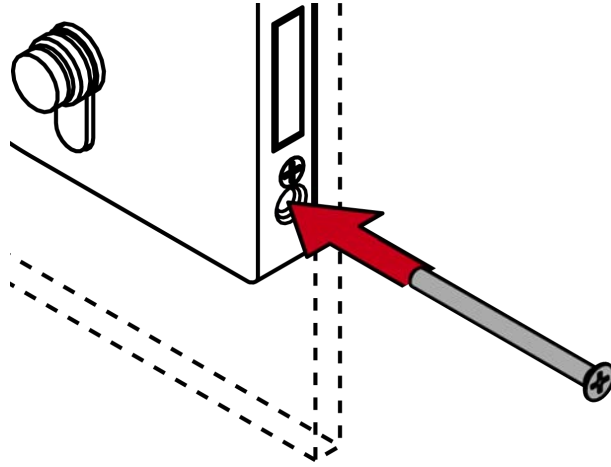

5. Screw the inside thumb-turn clockwise back onto the SI Digital Glass Door Cylinder AX.

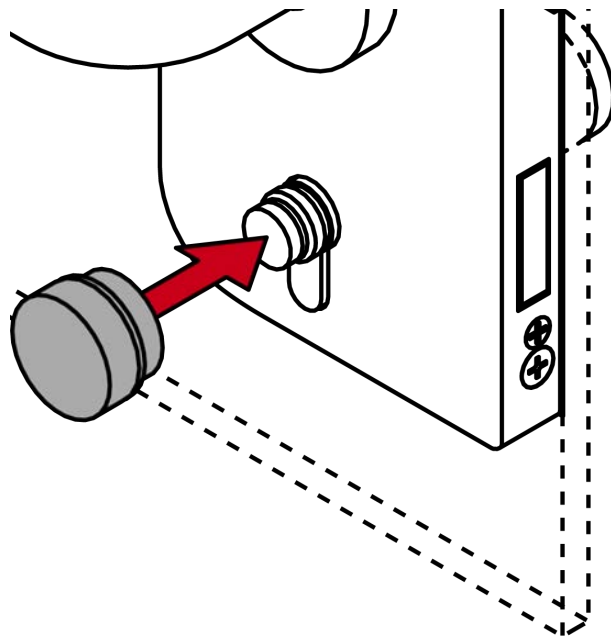

6. Secure the inside thumb-turn with the grub screw (SW 1.5 mm).

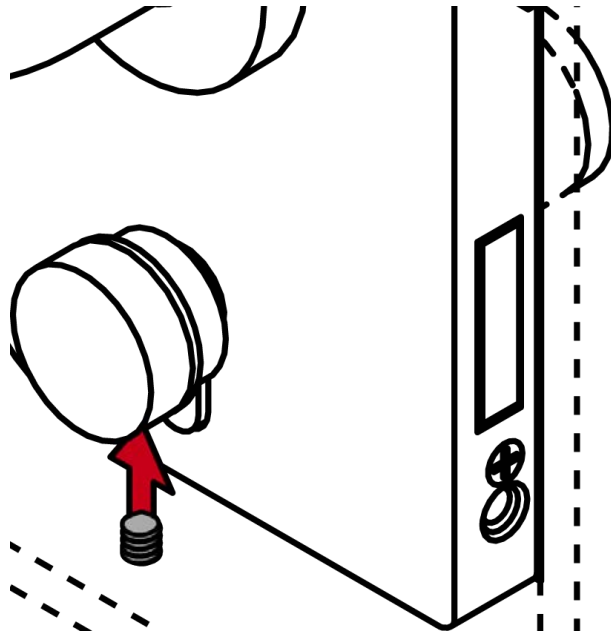

↳ SI Digital Glass Door Cylinder AX is installed.

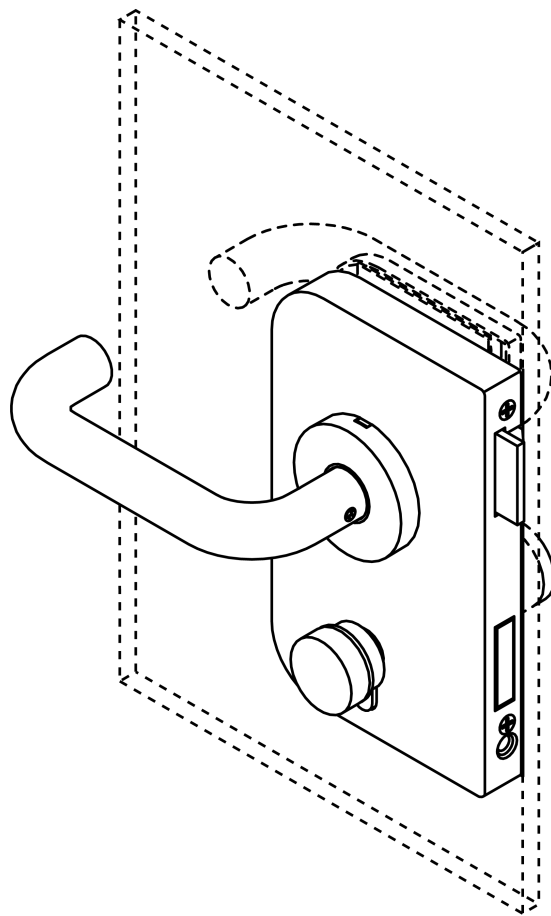



## 9.6 Installing the lever cylinder

- ✓ Open-ended/ring spanner SW22 available.
- ✓ Open-ended/ring spanner SW10 available.

1. Insert the SI Digital Lever Cylinder AX into the opening provided in the locker door.

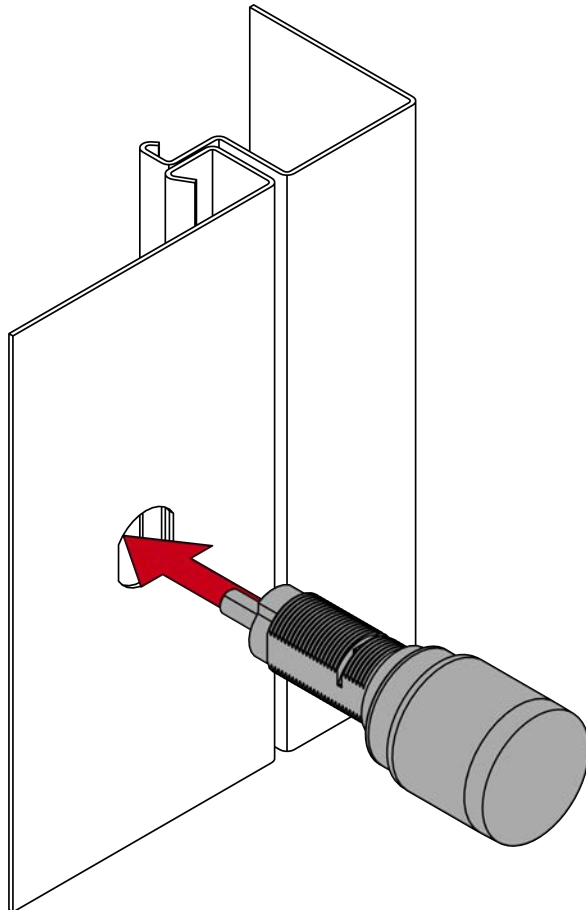

2. Place the large round washer on the cylinder profile so that it is flush with the inner side of the locker door.

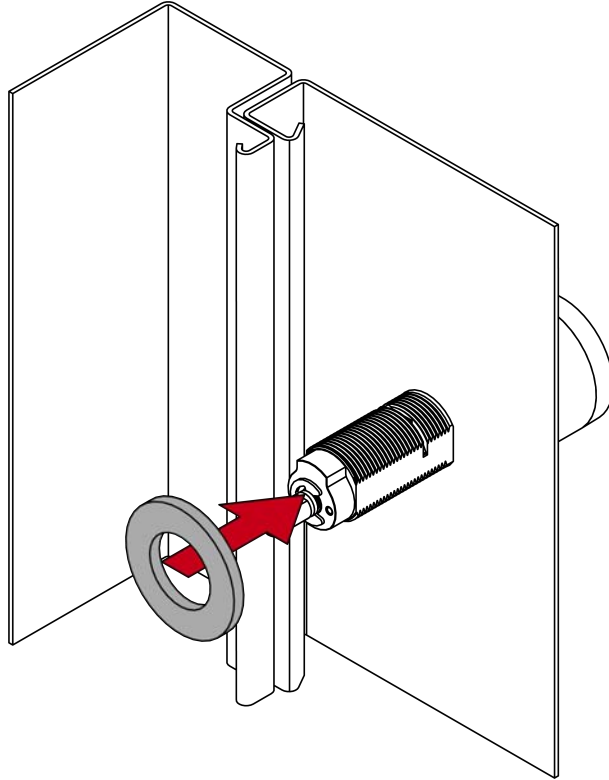

3. Place the nut on the cylinder profile and fasten it into place (SW22).

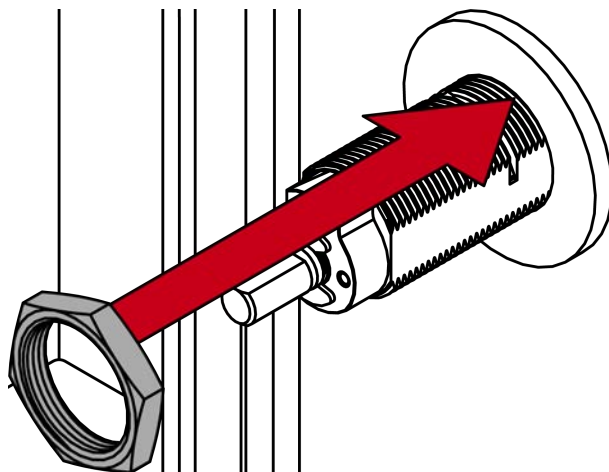

4. Place the small washer on the end of the cylinder profile.

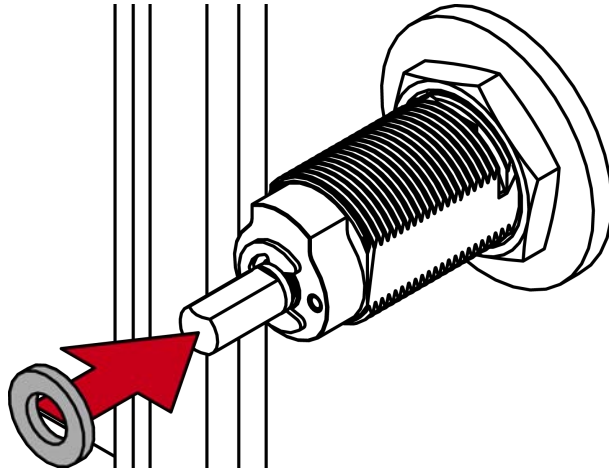

5. Place the spindle bushing on the small washer.

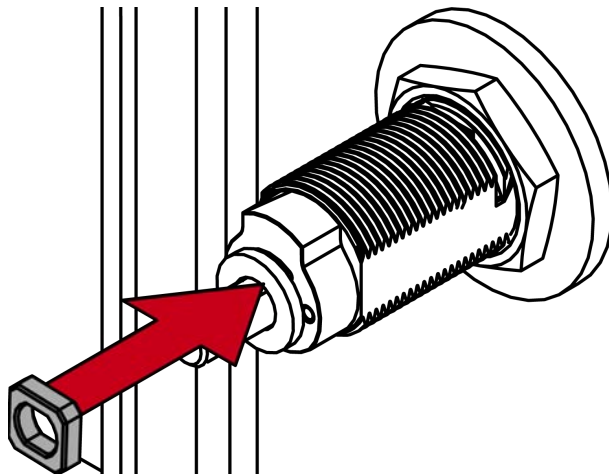

6. Place the lever on the spindle bushing.

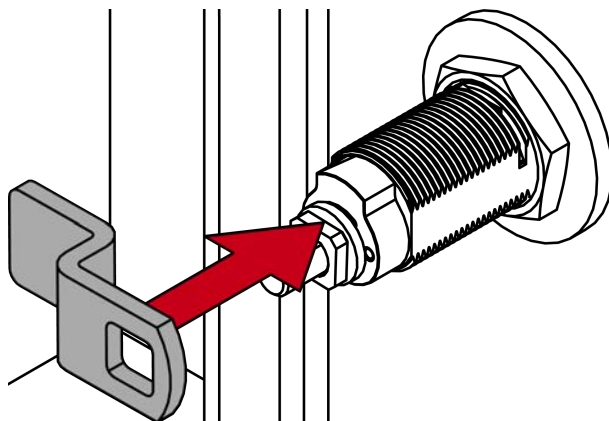

7. Place the second small washer on the lever.

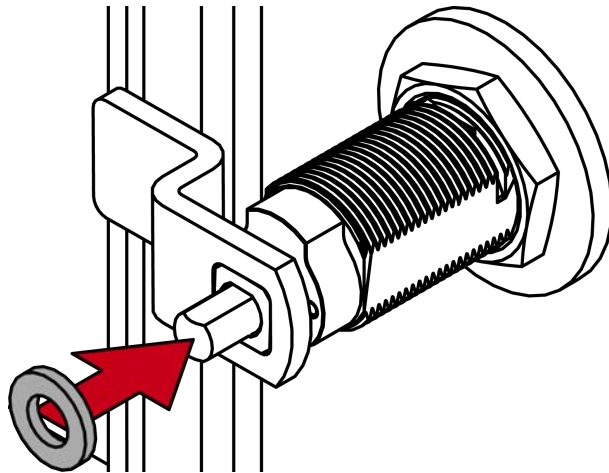

8. Then fasten the hexagon nut onto the lever (SW10).

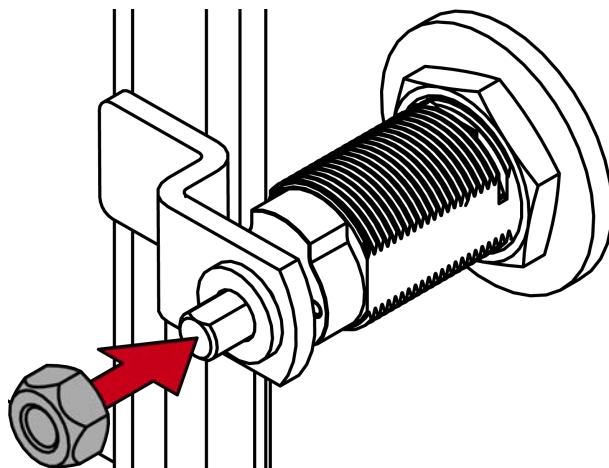

↳ SI Digital Lever Cylinder AX is fully installed.

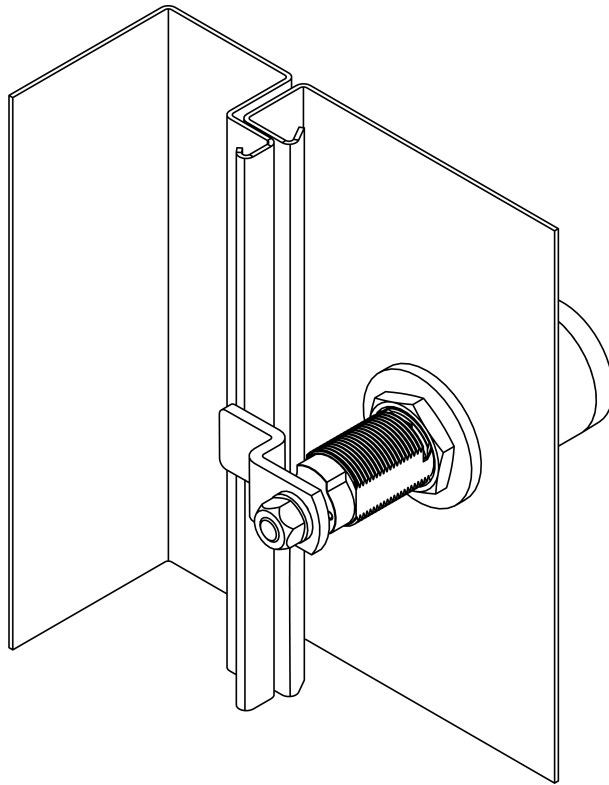

### 9.7 Functional test

Perform a function test after each installation and each battery change.

- ✓ Assembly or battery change completed
  - ✓ SI Digital Cylinder AX programmed
  - ✓ At least one identification medium authorised
1. Pull hard on the electronic or mechanical thumb-turns.
  2. Turn the electronic thumb-turns. The SI Digital Cylinder AX the AX locking cylinder must not be tight, nor rotate the tappet.
  3. Activate an authorised identification medium.
  4. Check that the SI Digital Cylinder AX engages and pushes out the locking bit.
- ↳ Mounting or battery change successfully completed.

### 9.8 AP functional test

Carry out a function test:

- After assembly
- After realignment
- After changes to the fastening screw
- After a modification (length modularity)

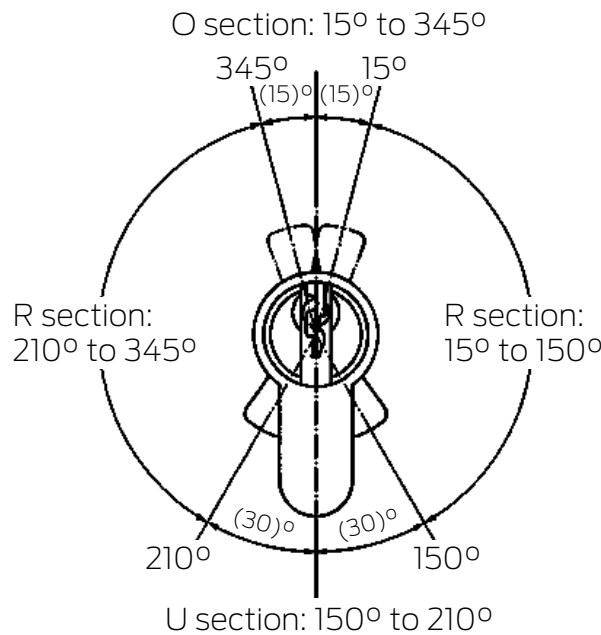

U section:	No restore force on the cam
R section:	Restore force section towards U section
O section:	Top dead point in dead bolt throw (no restore force on the cam)

- ✓ Functional test is carried out in escape direction.
  - ✓ The dead bolt is retracted.
1. With the cylinder engaged, first turn the thumb-turn in the direction of locking as far as the dead bolt throw in the R section.
    - ↳ Reset torque detectable...
  2. Release the thumb-turn.
    - ↳ Cylinder must automatically turn back into the U section.
  3. Activate an authorised identification medium.
    - ↳ Cylinder engages.
  4. Turn the engaged thumb-turn in the locking direction of the lock through the R section into the O section.
    - ↳ The dead bolt extends.
    - ↳ No reset torque detectable.
  5. Move the thumb-turn slightly over the threshold between the 'O' and 'R' section in the same direction of rotation.
  6. Release the thumb-turn.
    - ↳ The reset force must continue to turn the cam independently from this point to the U section.
    - ↳ The dead bolt extends completely.
    - ↳ If the thumb-turn does not automatically rotate as far as the 'U' section, either the fastening screw has been tightened too firmly or the locking device has been aligned incorrectly. The test is to be

repeated after the fault has been eliminated. A fastening screw which has been tightened too firmly acts as a brake on the restoring force mechanism.

7. Lock the door and check that the locking device functions correctly by pressing the door fitting or panic bar in the direction of escape.
  - ↳ The dead bolt must snap back.
  - ↳ The door must open easily.
  - ↳ If the dead bolt does not draw back when the handle is turned or the door fitting catches, either the locking cylinder or the locking device is incorrectly aligned or defective. The test is to be repeated after the fault has been eliminated as described above.

## 10. Customise Cylinder AX

### 10.1 LockNode

#### 10.1.1 Remove cap

✓ Special tool available.

1. Align the thumb turn horizontally.

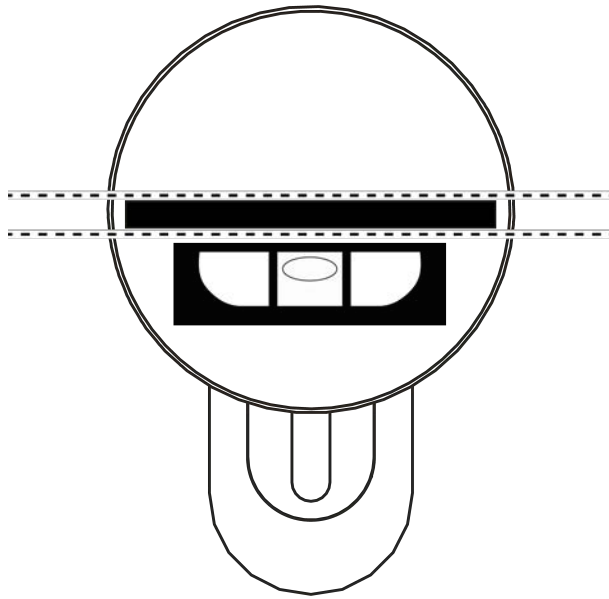

2. Attach the special tool.

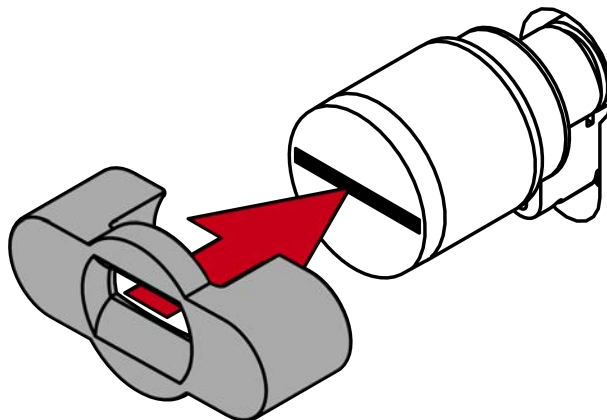



3. Align the special tool so that the logo is parallel to the recess.

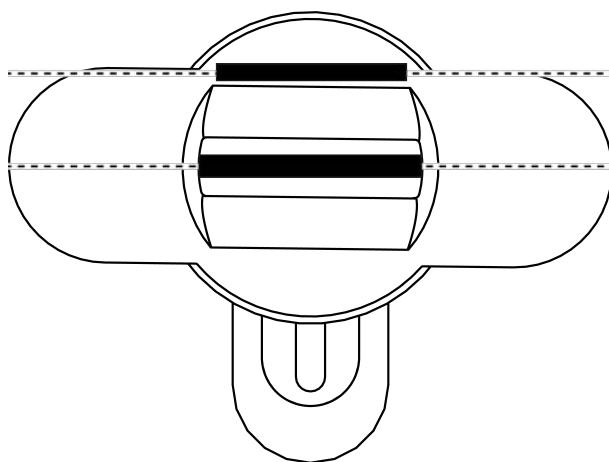

4. Hold the special tool and thumb turn cap firmly at the same time and turn them together 1-2° clockwise first and then counter-clockwise.



#### NOTE

##### Slipping when turning

The surface of the thumb turn cap can be slippery and the cap can be difficult to turn (especially with WP versions, recognizable by the blue cylinder neck ring or the lasered marking on the inner side of the cylinder profile).

- Wear non-slip gloves.

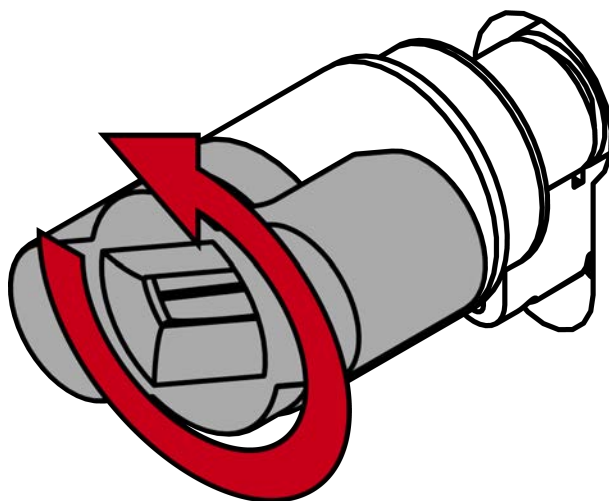

5. Remove the tool and cover.  
↳ Cap is disassembled.

### 10.1.2 Installation

1. Push the latch inward and open the battery cover.

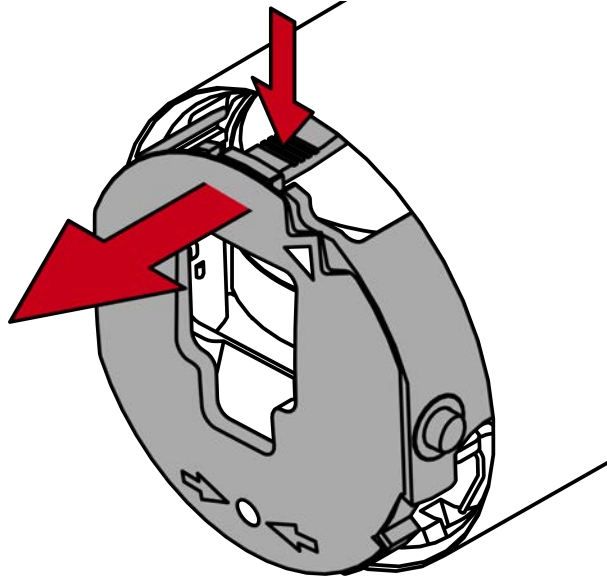

2. Slide the LockNode into the guides provided as shown.

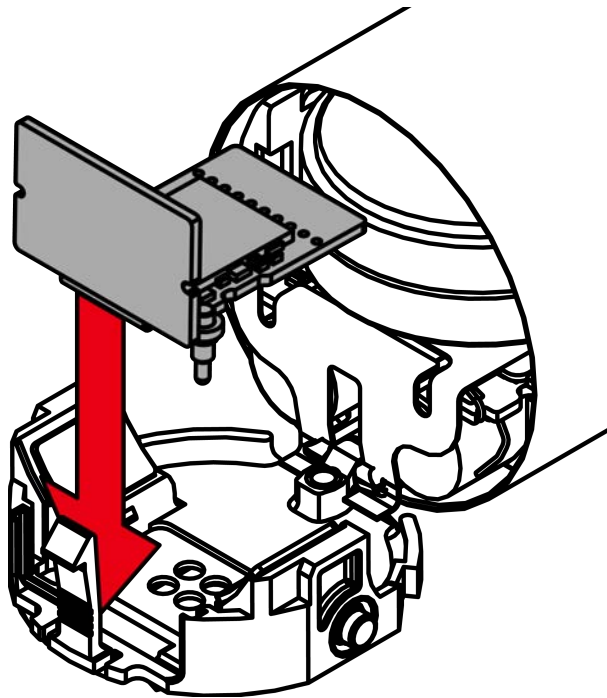

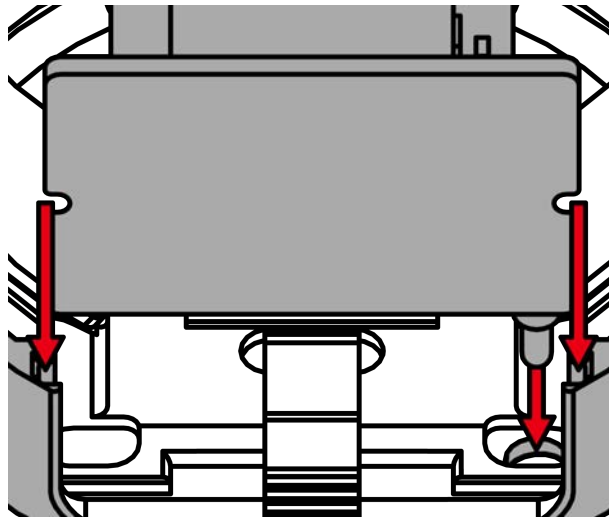

3. Close the battery cover and LockNode.

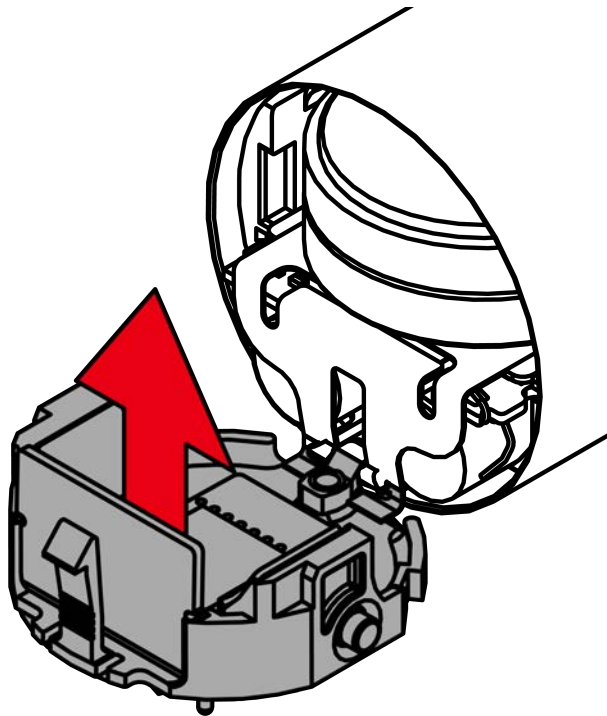

- ↳ The locking device bleeps and flashes red four times.
- ↳ LockNode is installed.

### 10.1.3 Attach the cap

✓ Special tool available.

1. Put on the cover.

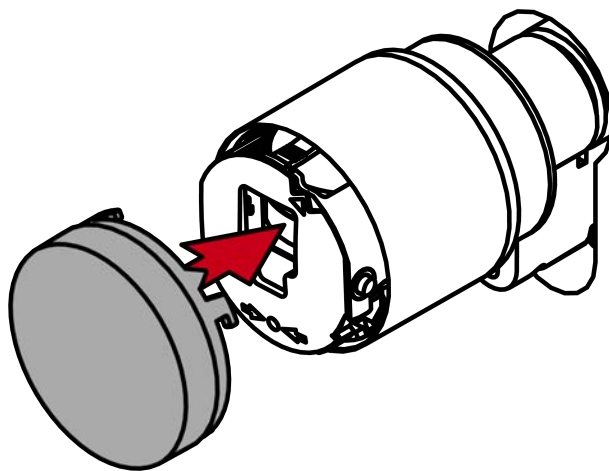
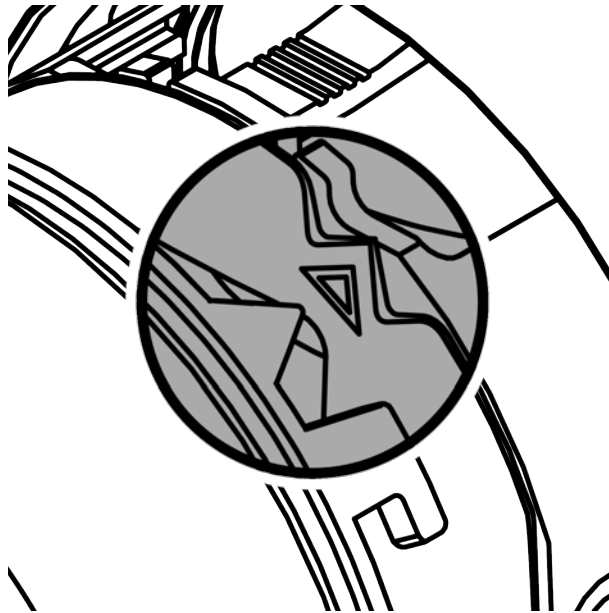

2. Turn the cover clockwise.

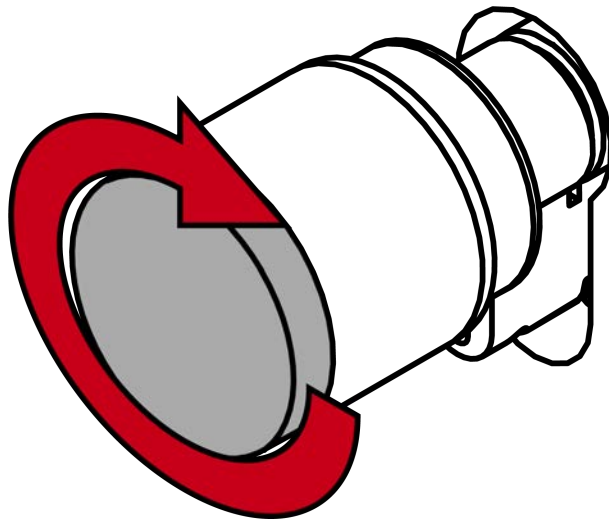

↳ The cover snaps into place with one click.

## 10.2 Replacement caps

The caps can be replaced without removing or programming the SI Digital Cylinder AX .

### 10.2.1 Remove cap

✓ Special tool available.

1. Align the thumb turn horizontally.

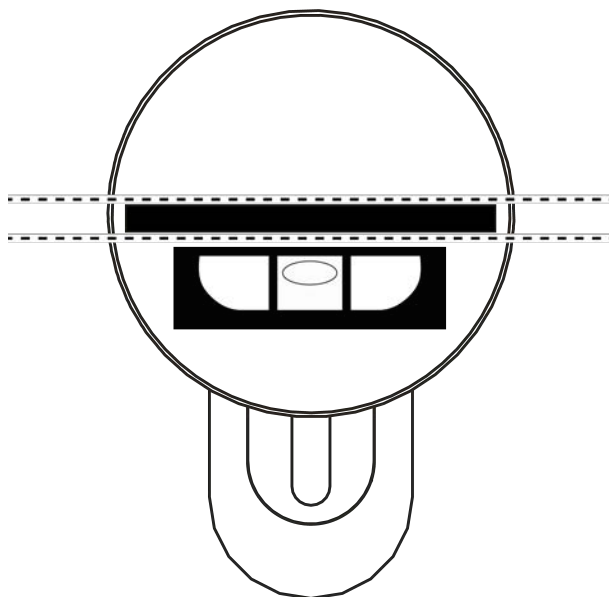

2. Attach the special tool.

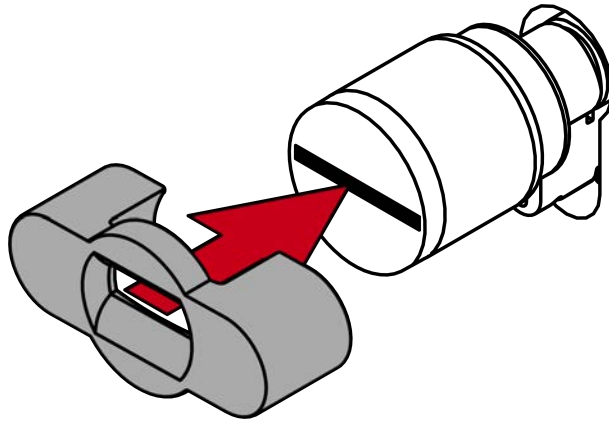

3. Align the special tool so that the logo is parallel to the recess.

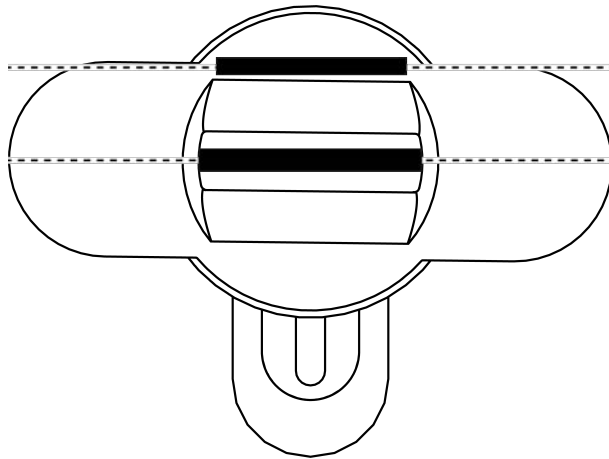

4. Hold the special tool and thumb turn cap firmly at the same time and turn them together 1-2° clockwise first and then counter-clockwise.



#### NOTE

##### Slipping when turning

The surface of the thumb turn cap can be slippery and the cap can be difficult to turn (especially with WP versions, recognizable by the blue cylinder neck ring or the lasered marking on the inner side of the cylinder profile).

- Wear non-slip gloves.

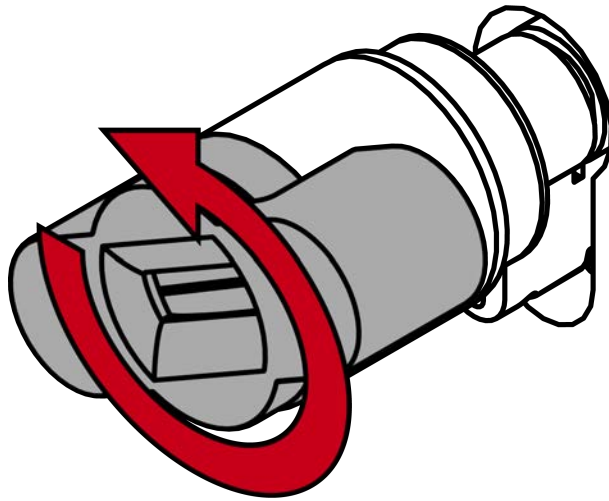

5. Remove the tool and cover.

↳ Cap is disassembled.

#### 10.2.2 Attach the cap

✓ Special tool available.

1. Put on the cover.

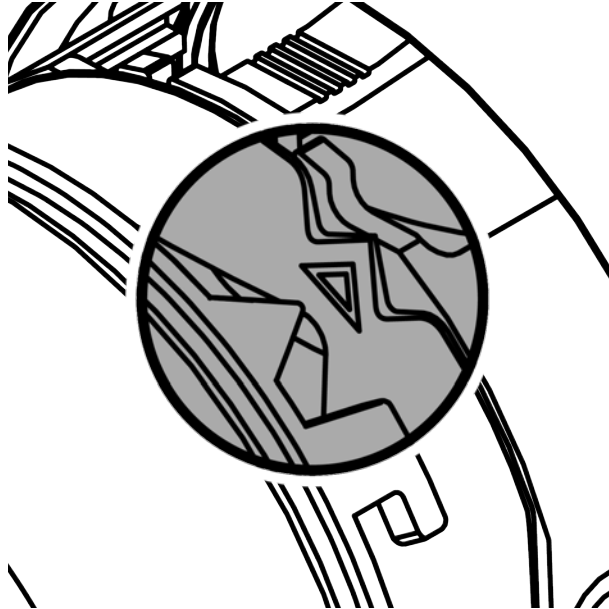

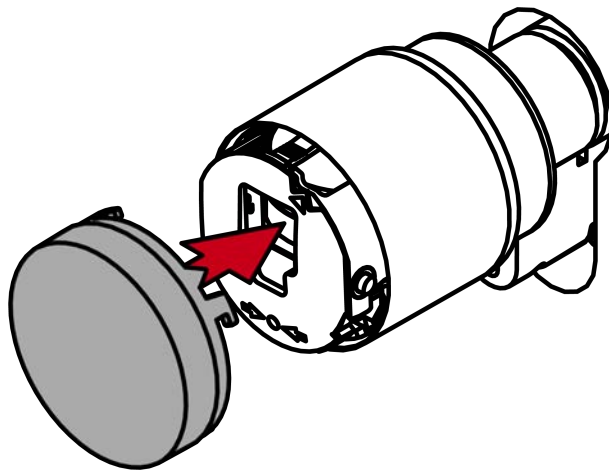

2. Turn the cover clockwise.

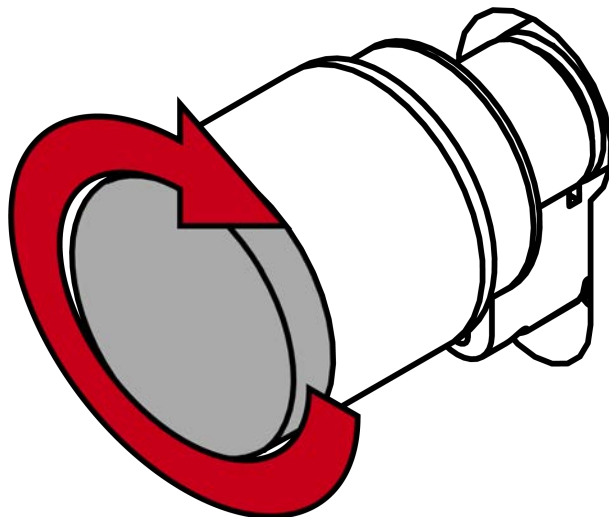

↳ The cover snaps into place with one click.

### 10.3 Length modularity

#### 10.3.1 Extend Cylinder AX

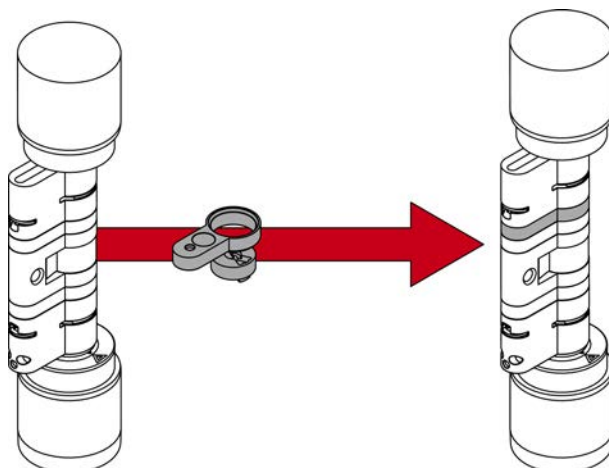



The core extension and profile extension must be the same length. You also need an extension bolt for the desired length.

- ✓ Extractor for releasing the clamp
- ✓ Spacer for aligning the extension bolt
- ✓ Clamp block for pressing in the clamp

1. Place the Cylinder AX in the thumb-turn assembly tool.

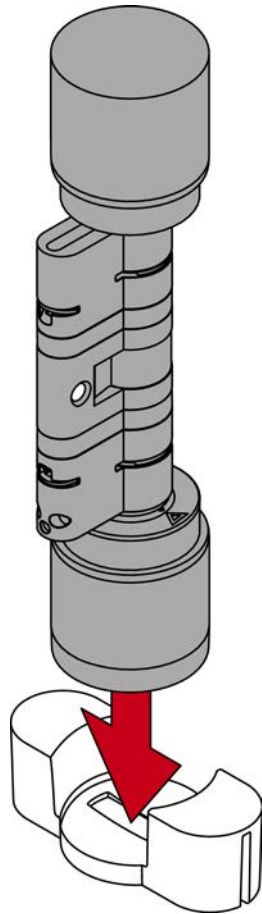

2. Hook the tip of the extractor into the clamp.

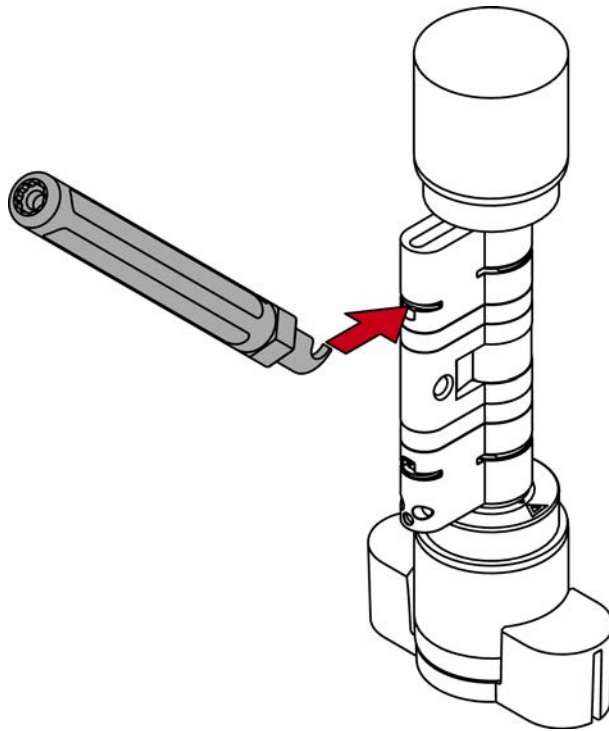

3. Lever the clamp out of the profile cylinder by moving the extractor to the centre of the cylinder.

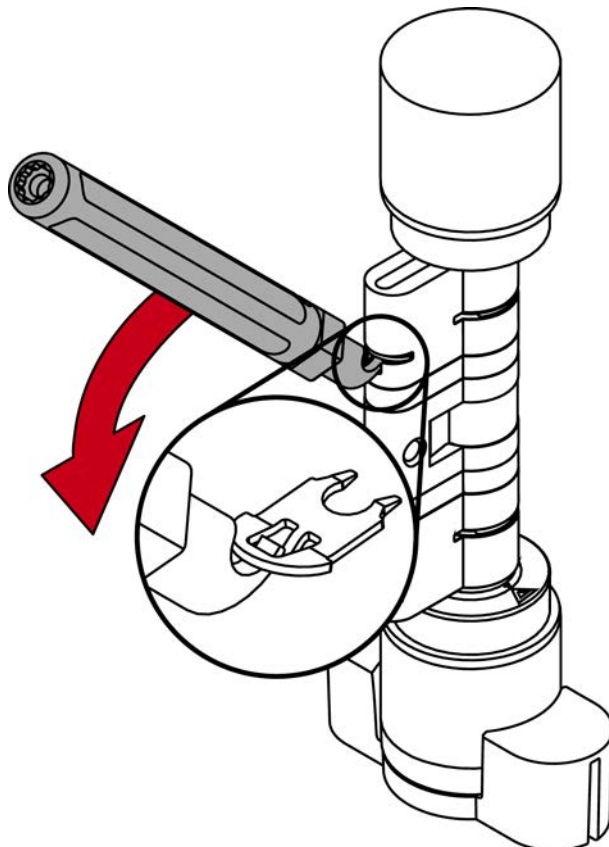

4. Pull the clamp completely out of the profile cylinder.

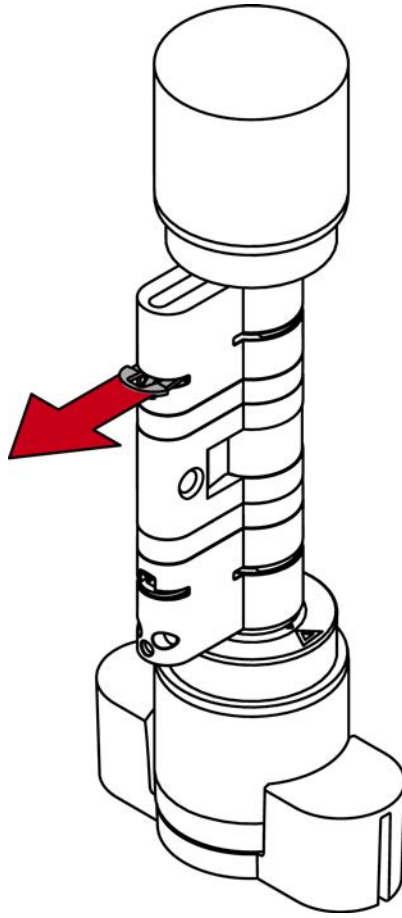

5. Disassemble the two cylinder halves.

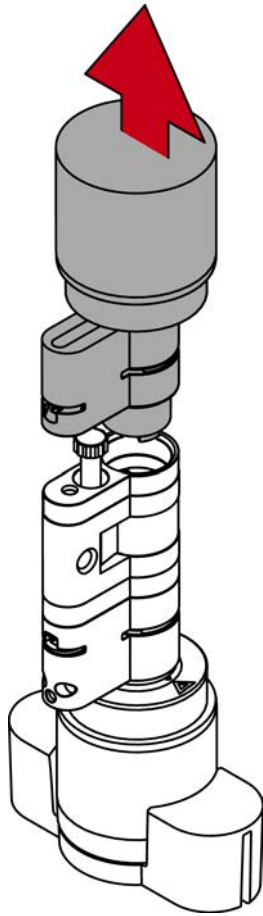

6. Use the extractor to unscrew the extension bolt.

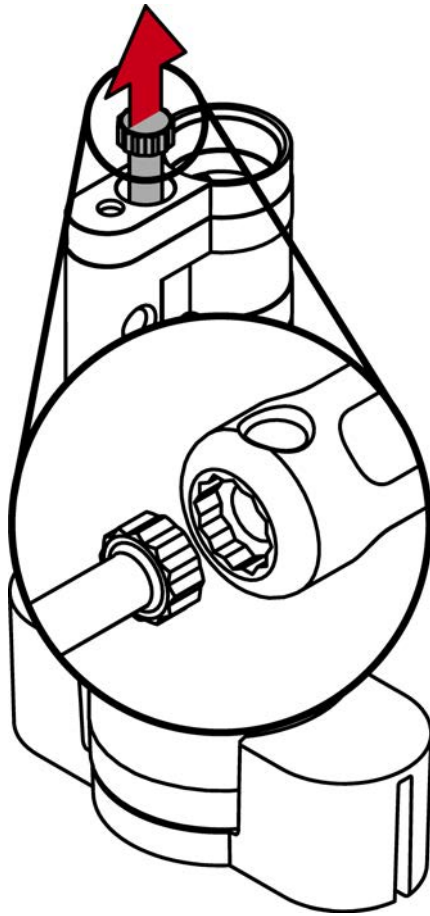

7. Insert suitable core extensions.

8. Attach suitable profile extensions.

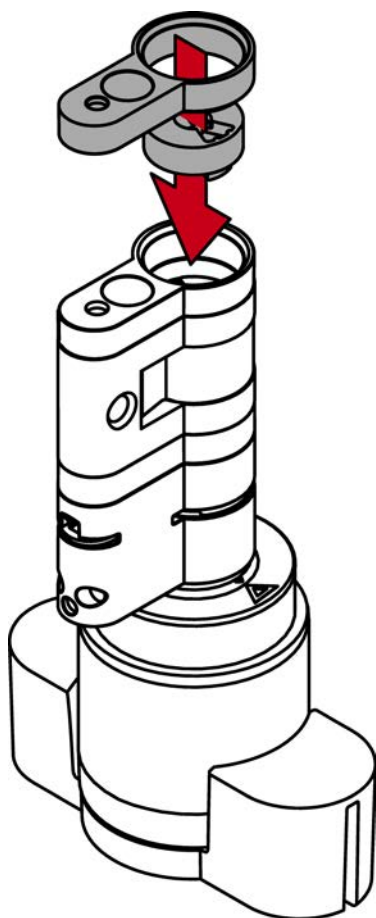

9. Place the spacer.

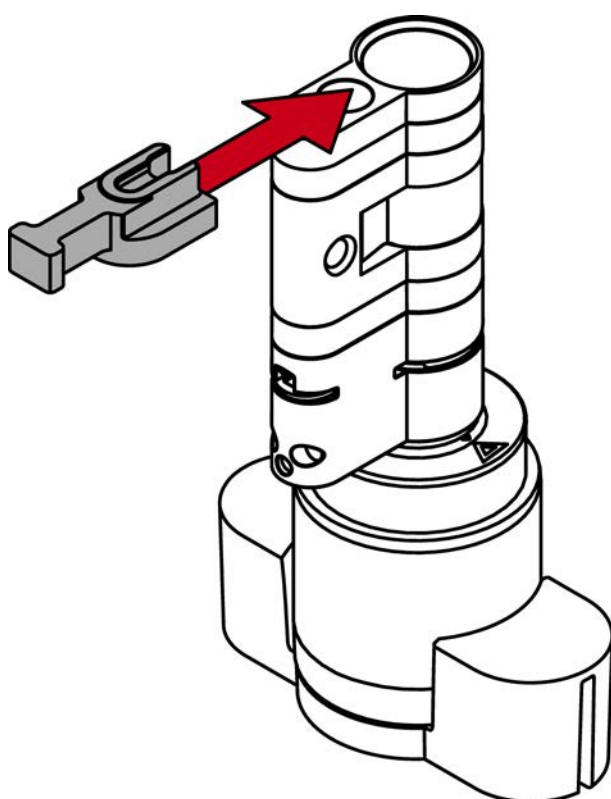

10. Screw in a suitable extension bolt with the extractor until it rests on the spacer.



**NOTE**

**Length on bolt head**

You will find a number on the bolt head. This number is the length of the cylinder profile to which the bolt fits.

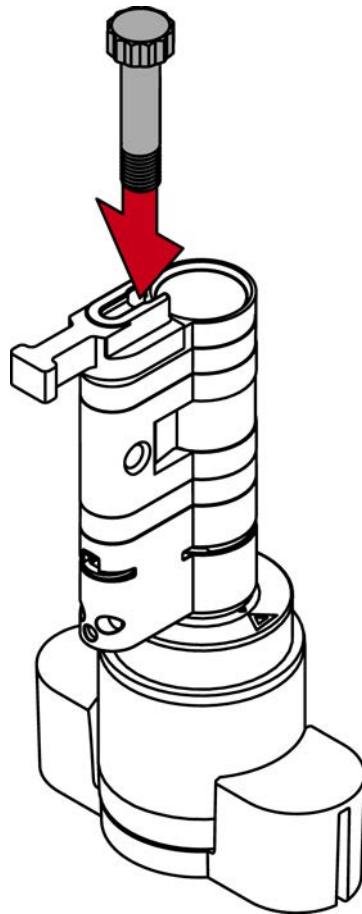

11. Reassemble the two cylinder halves.

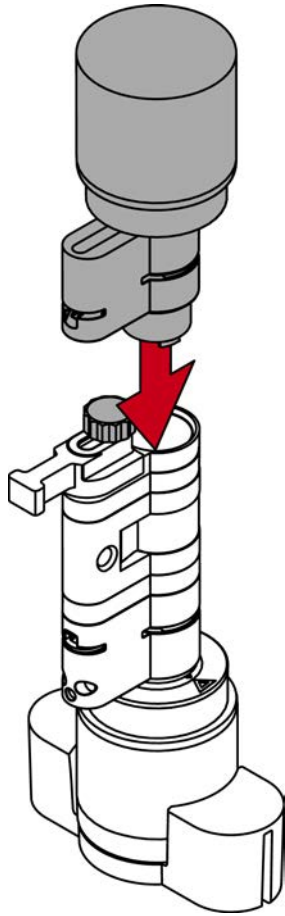

↳ Extension bolt is protected against twisting.



12. Pull the spacer off again.

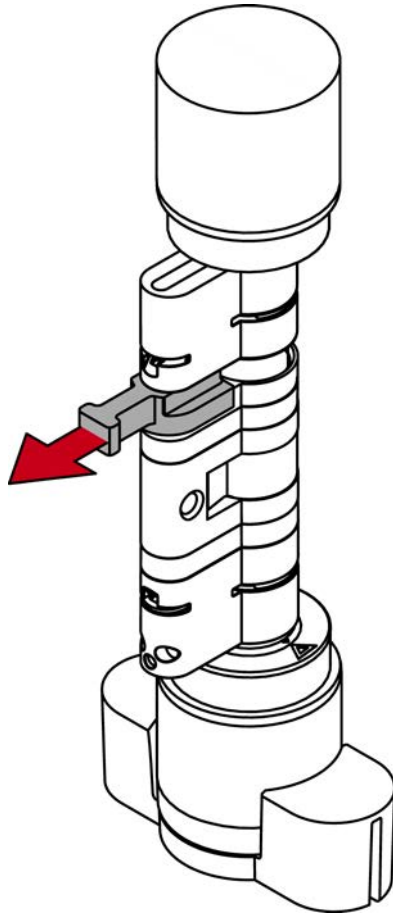

13. Push the halves together completely.

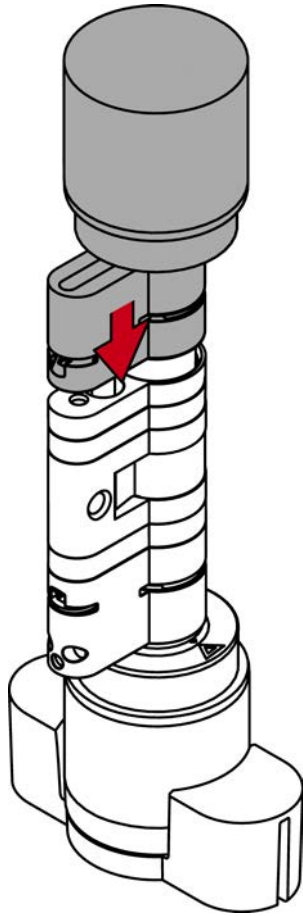

14. Place the clip back into the slot of the profile cylinder with its lug facing the fastening screw and press the clamp with your thumb so that it can no longer fall out.

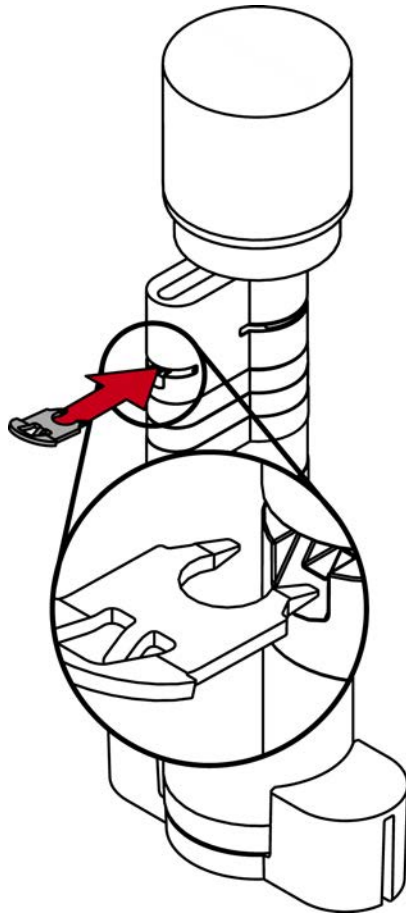

15. Insert the cylinder into the clamping block so that the profile cylinder and the thumb-turn lie flush in the recesses.

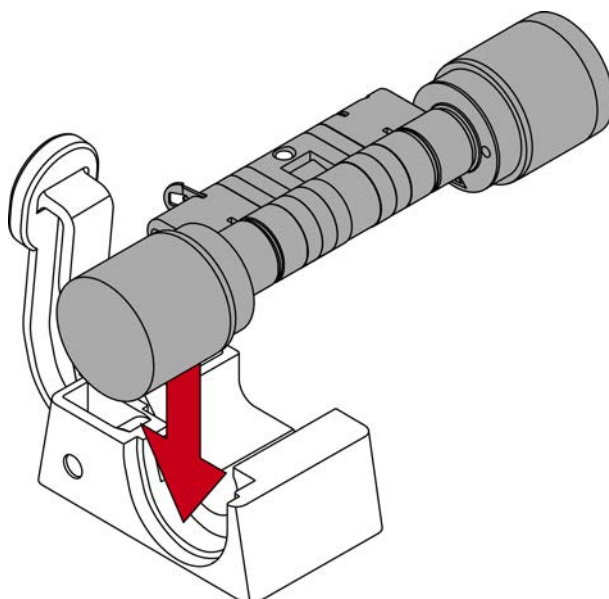

- ↳ The lever of the clamping block is reinforced at one point with a metal plate. The bracket that was previously inserted lies opposite this metal plate.

16. Push the clamp block lever towards the base plate until the clamp is fully seated in the profile cylinder.

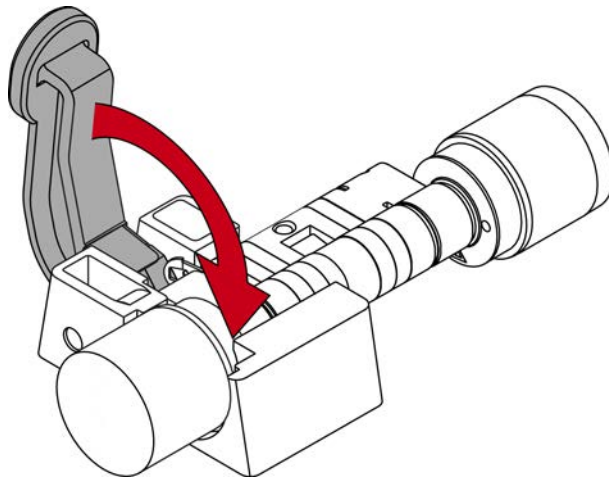

- ↳ Cylinder AX is extended.

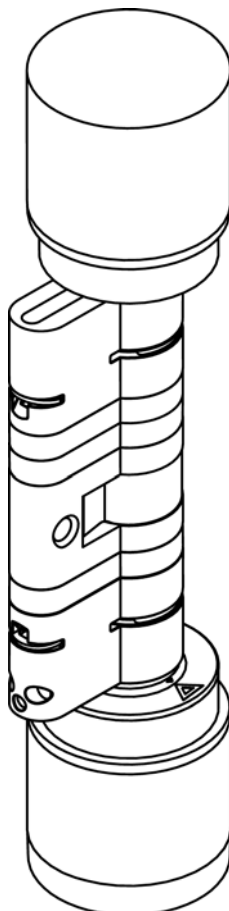

### 10.3.2 Shorten Cylinder AX

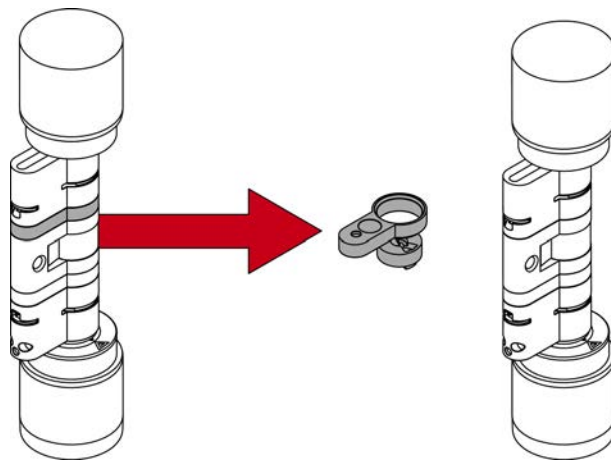

You need a bolt for the desired length.

- ✓ Extractor for releasing the clamp
- ✓ Spacer for aligning the bolt
- ✓ Clamp block for pressing in the clamp

1. Place the Cylinder AX in the thumb-turn assembly tool.

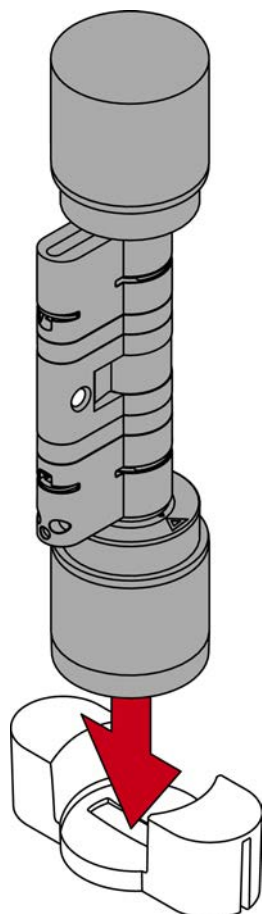

2. Hook the tip of the extractor into the clamp.

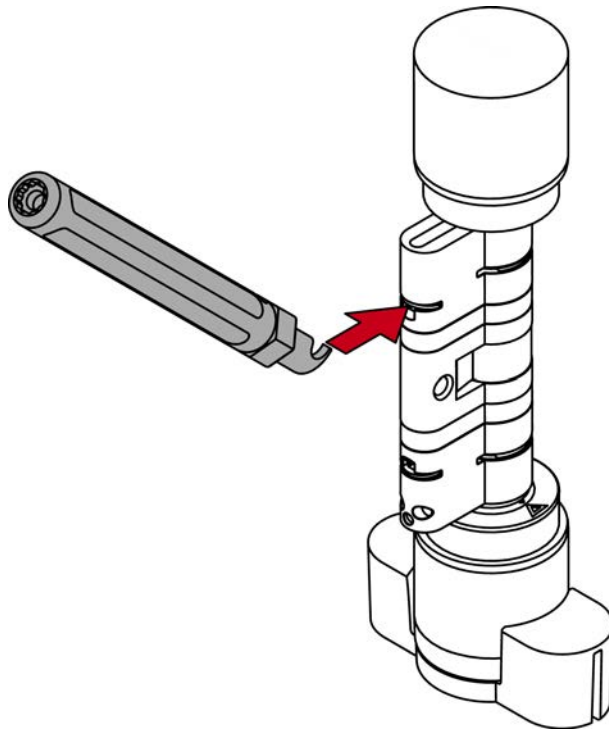

3. Lever the clamp out of the profile cylinder by moving the extractor to the centre of the cylinder.

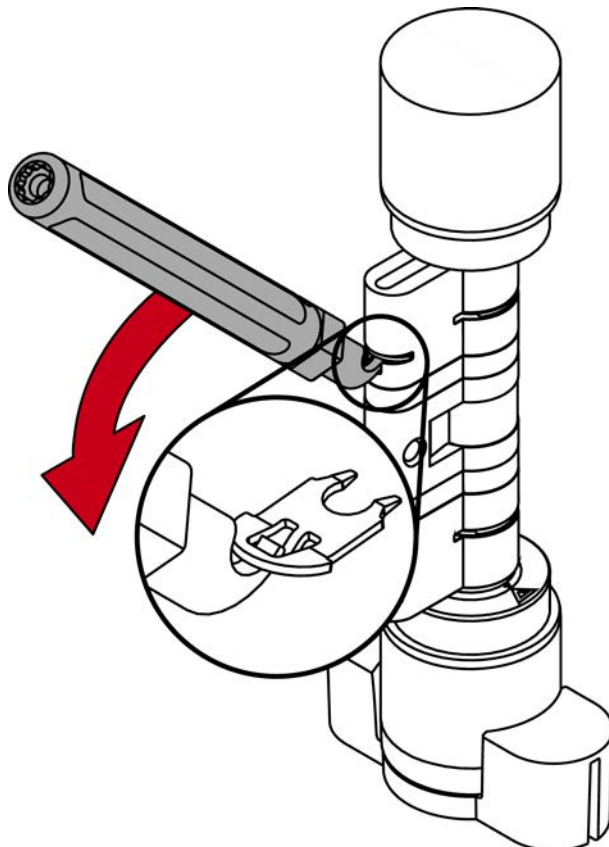

4. Pull the clamp completely out of the profile cylinder.

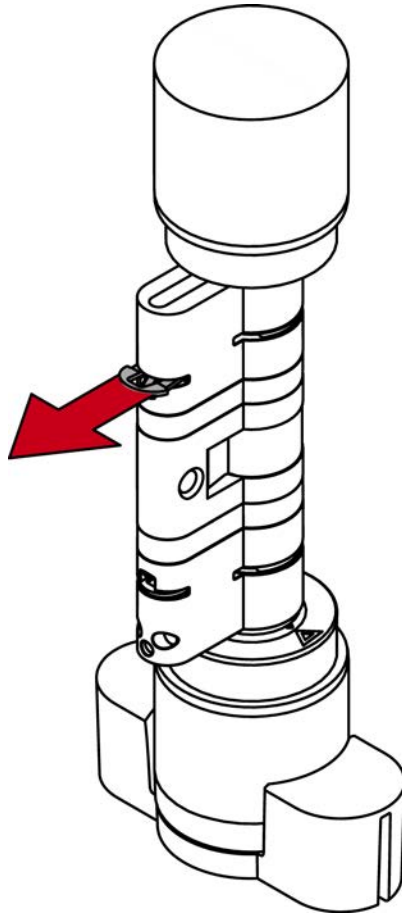

5. Disassemble the two cylinder halves.

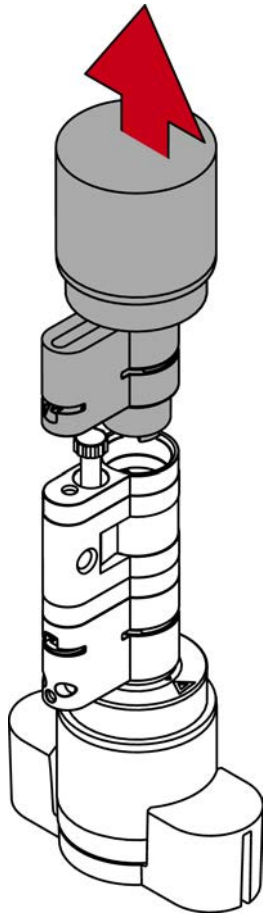



6. Unscrew the bolt with the extractor.

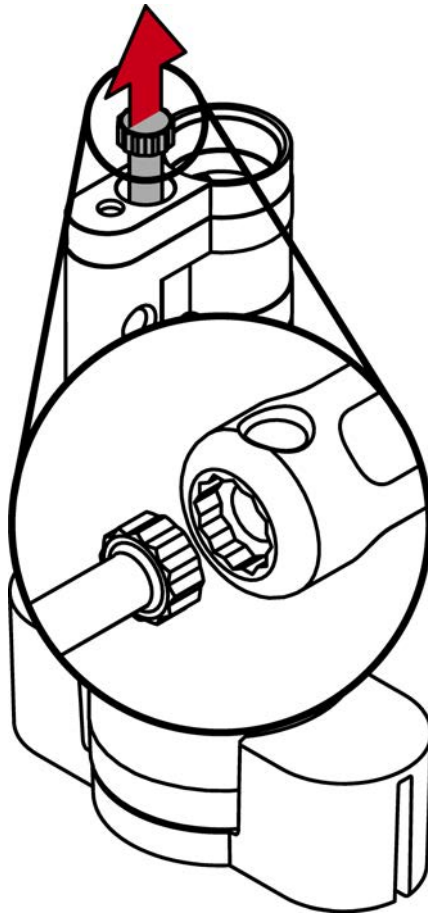

7. Remove the profile extension.

8. Remove the core extension.

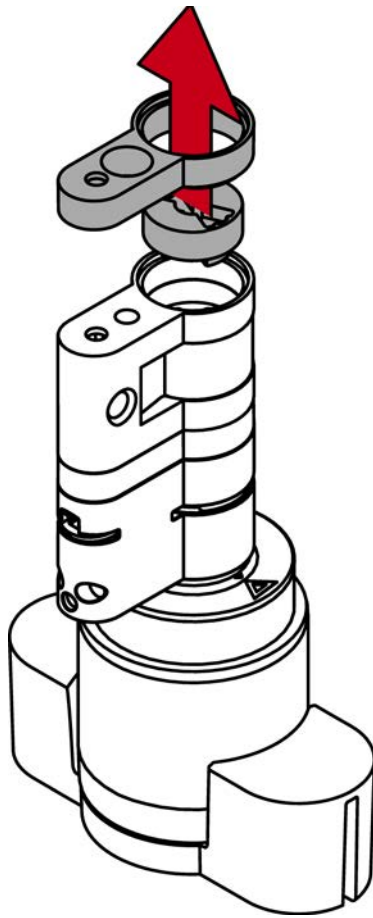

9. Place the spacer.

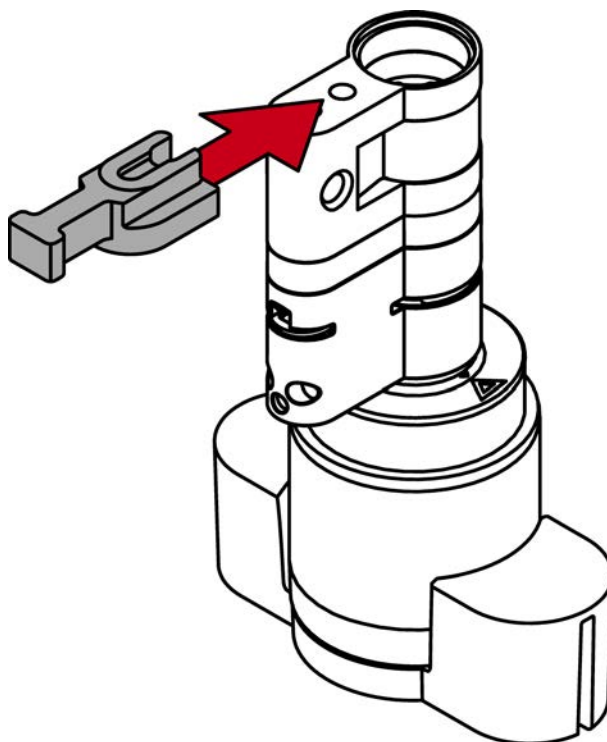

10. Screw in a suitable bolt with the extractor until it rests on the spacer.



**NOTE**

**Length on bolt head**

You will find a number on the bolt head. This number is the length of the cylinder profile to which the bolt fits.

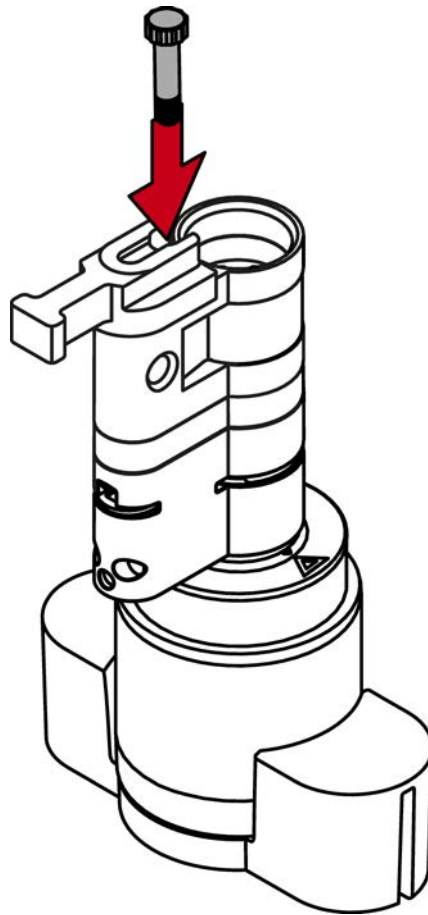

11. Reassemble the two cylinder halves.

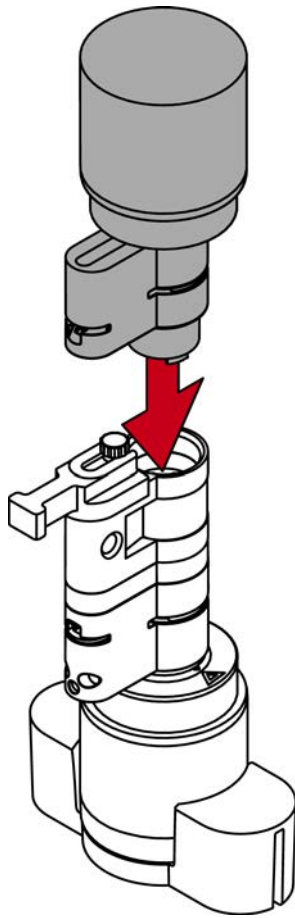

↳ Bolt is protected against twisting.

12. Pull the spacer off again.

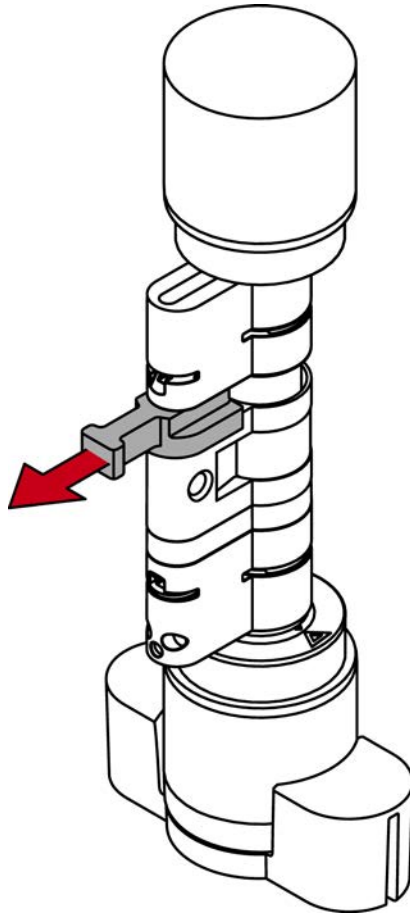

13. Push the halves together completely.

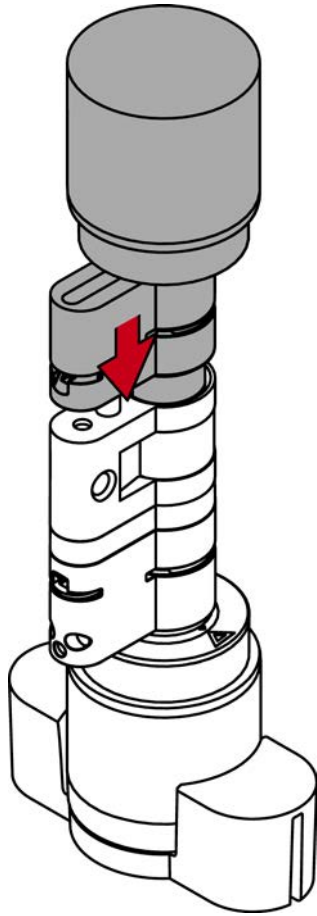

14. Refit the clip into the slot of the profile cylinder with the lug facing the fastening screw.

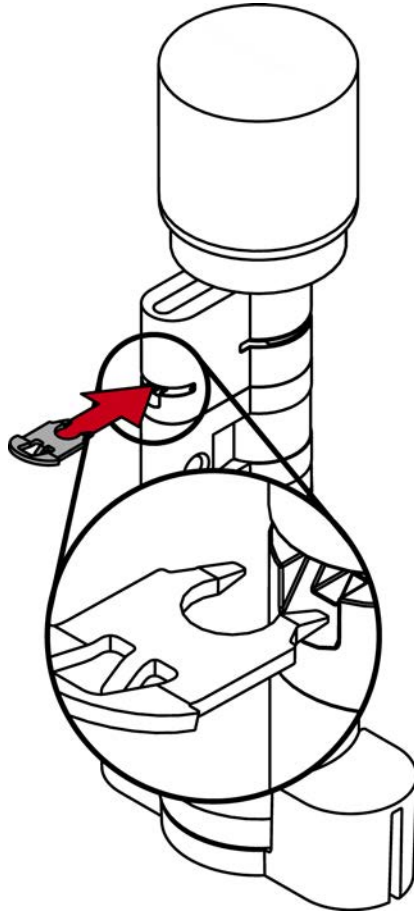

15. Insert the cylinder into the clamping block so that the profile cylinder and the thumb-turn lie flush in the recesses.

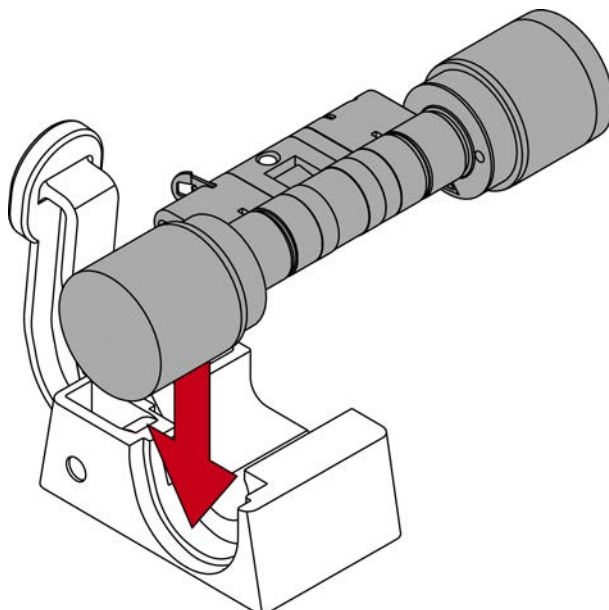

- ↳ The lever of the clamping block is reinforced at one point with a metal plate. The bracket that was previously inserted lies opposite this metal plate.

16. Push the clamp block lever towards the base plate until the clamp is fully seated in the profile cylinder.

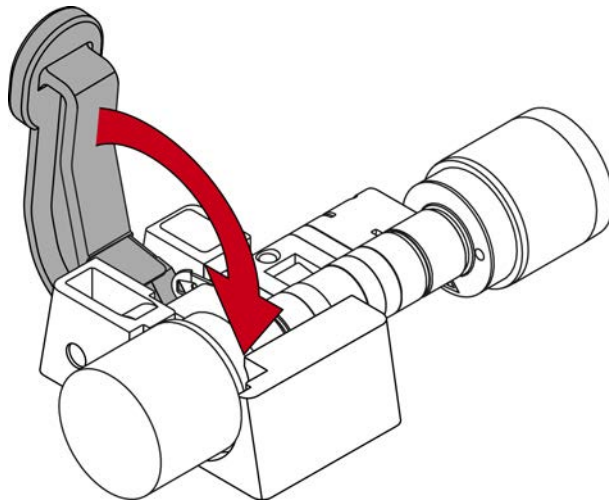

- ↳ Cylinder AX is shortened.

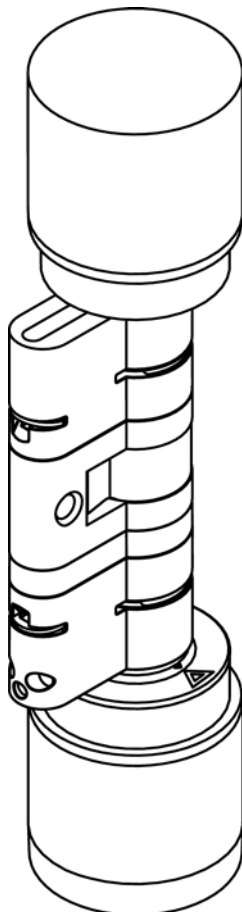



### 10.3.3 Combine CO cylinders to FD

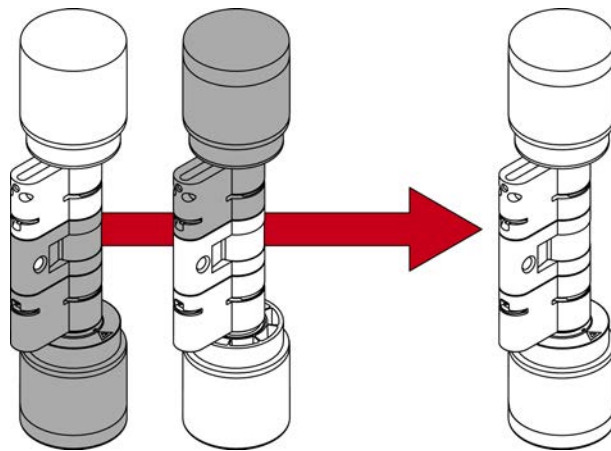

You can assemble a freely rotating AX cylinder from two AX comfort cylinders.

- ✓ Extractor for releasing the clamp
- ✓ Spacer for aligning the extension bolt
- ✓ Clamp block for pressing in the clamp

1. Place the first comfort cylinder AX in the thumb-turn assembly tool with the mechanical thumb-turn facing upwards.

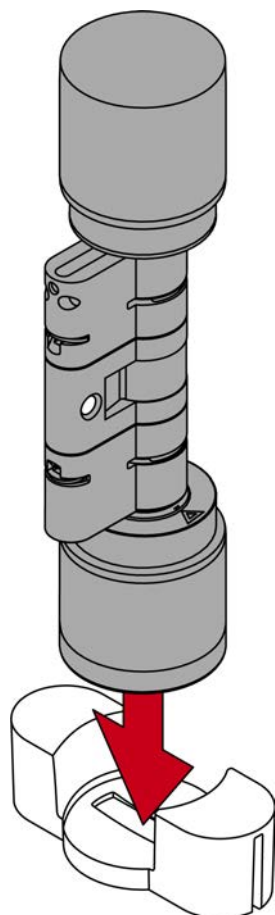

2. Hook the tip of the extractor into the clamp.

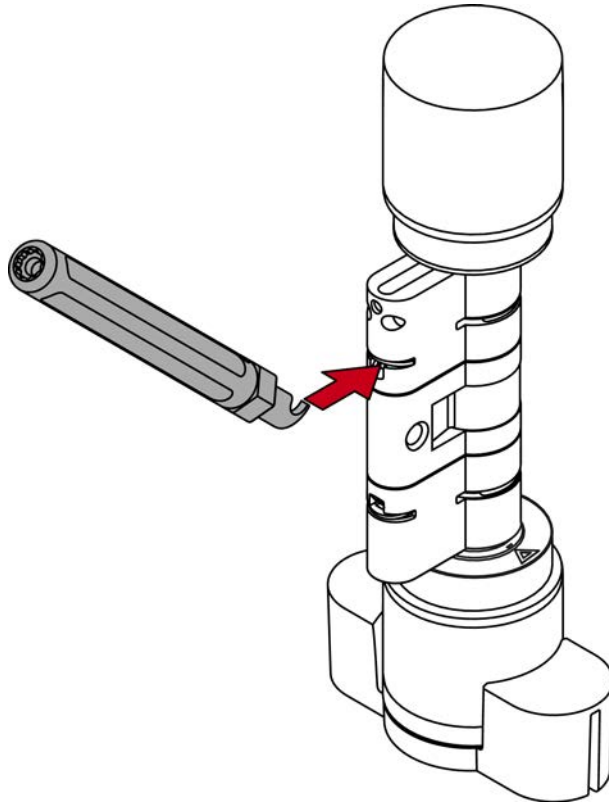

3. Lever the clamp out of the profile cylinder by moving the extractor to the centre of the cylinder.

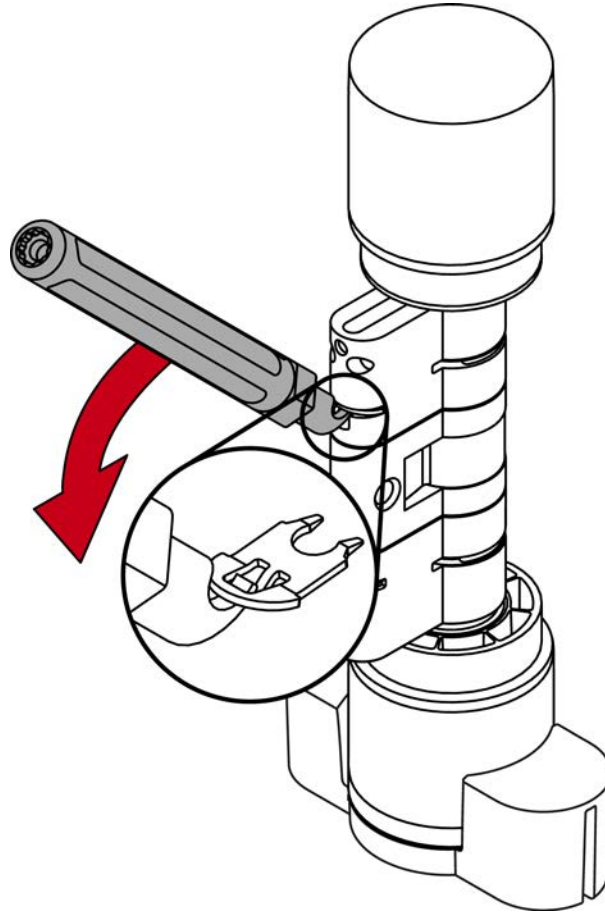

4. Pull the clamp completely out of the profile cylinder.

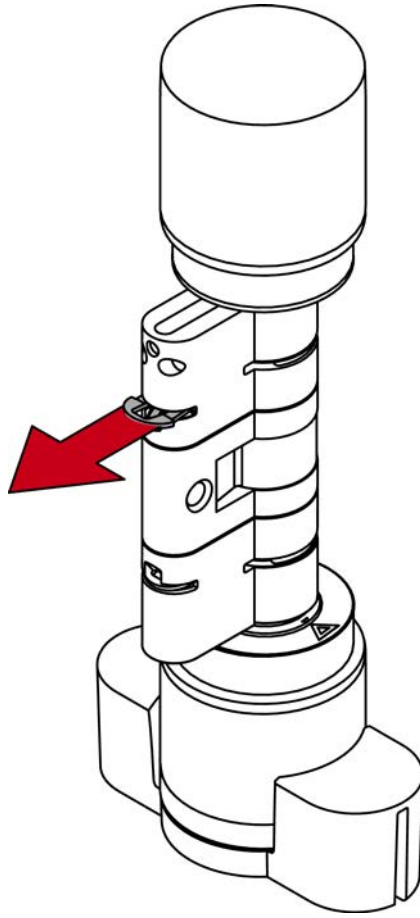

5. Disassemble the two cylinder halves.

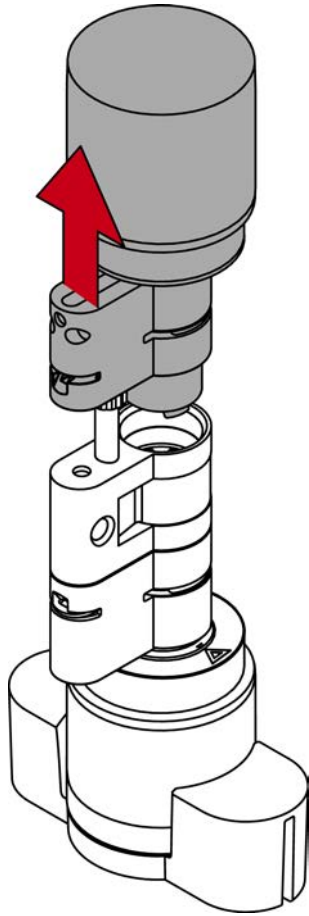

↳ First cylinder half prepared with centre piece and tappet piece.

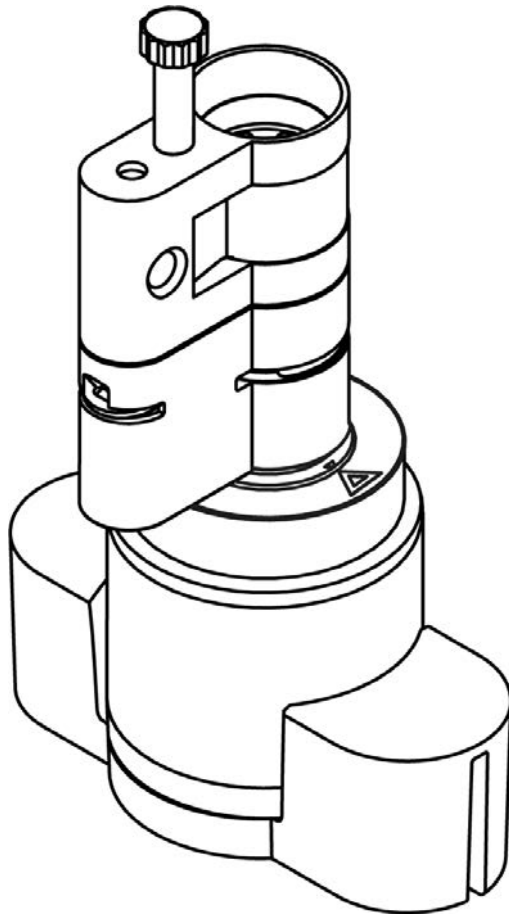

6. Place the second comfort cylinder AX in the thumb-turn assembly tool with the electronic thumb-turn facing upwards.

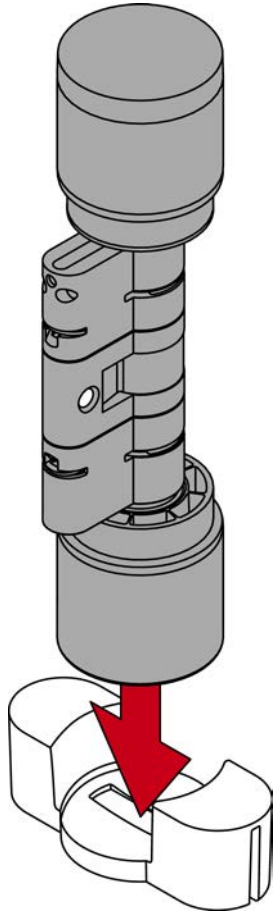

7. Hook the tip of the extractor into the clamp.

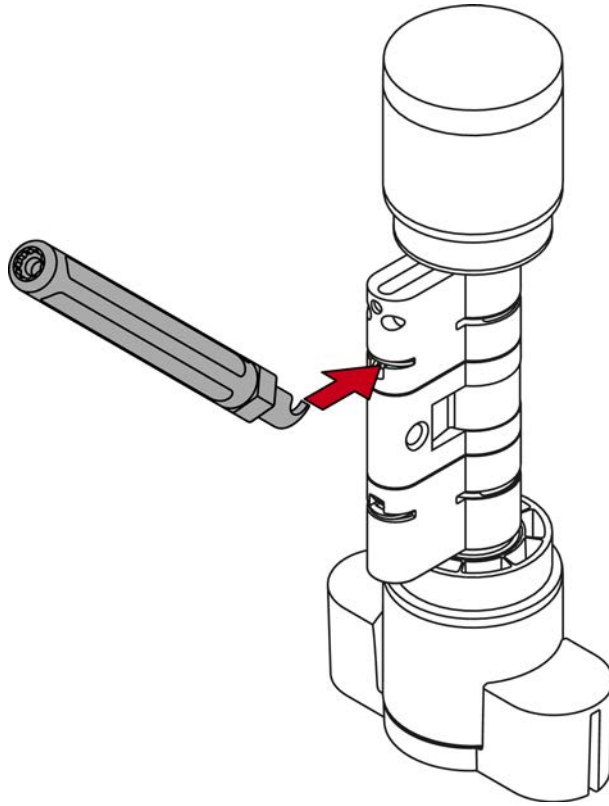



8. Lever the clamp out of the profile cylinder by moving the extractor to the centre of the cylinder.

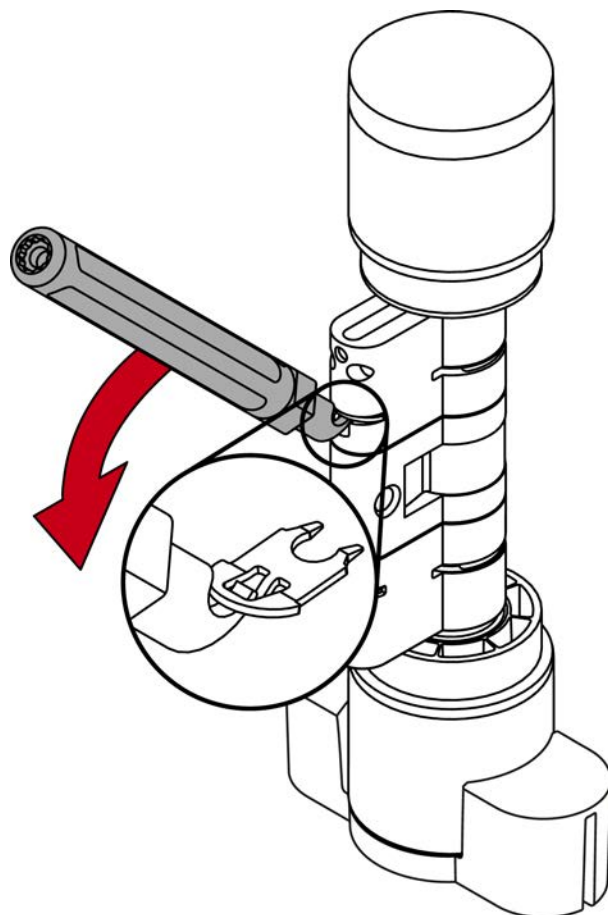

9. Pull the clamp completely out of the profile cylinder.

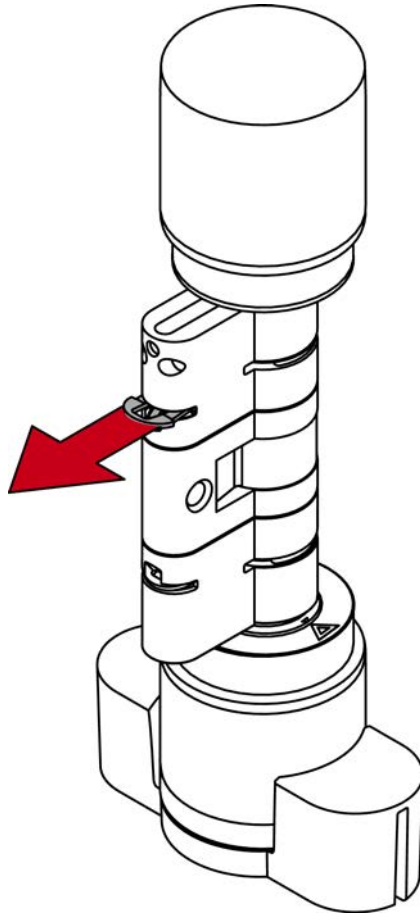

10. Disassemble the two cylinder halves.

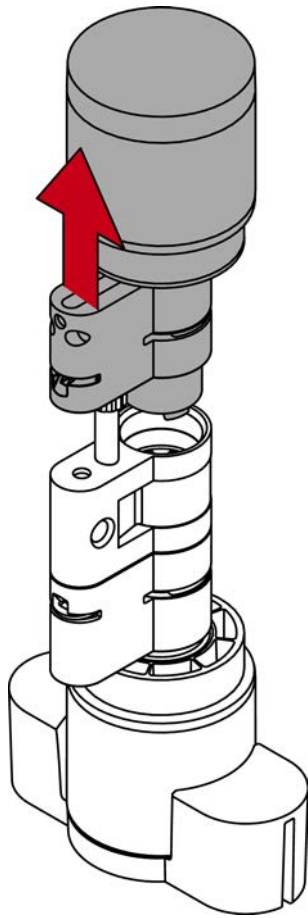

↳ Second cylinder half prepared without centre piece.

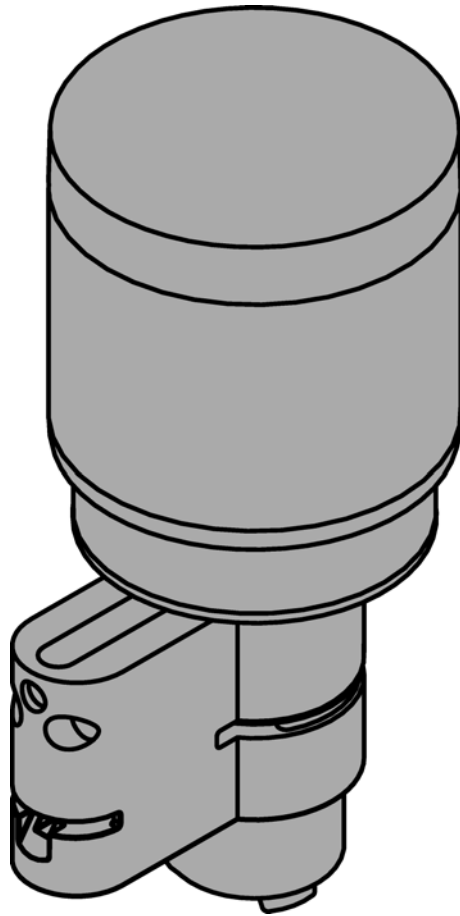

11. Place the first cylinder half on the second cylinder half.

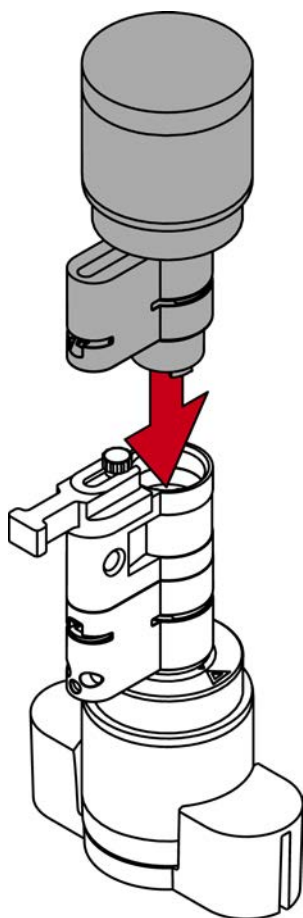

12. Refit the clip into the slot of the profile cylinder with the lug facing the fastening screw.

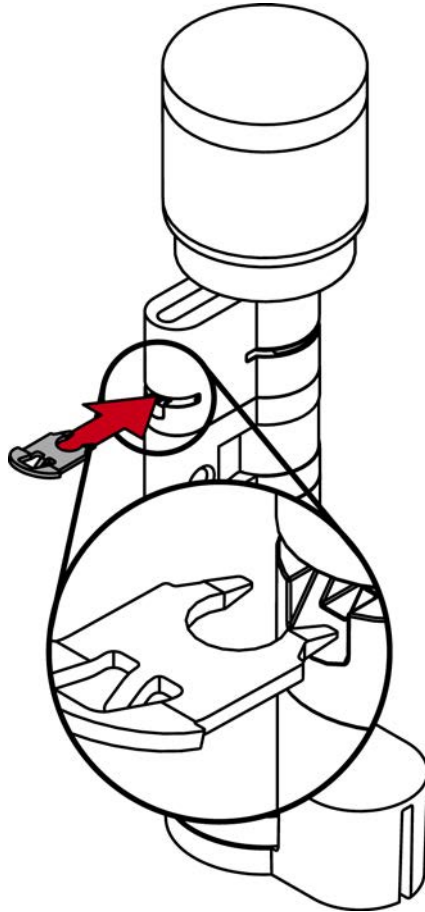

13. Insert the cylinder into the clamping block so that the profile cylinder and the thumb-turn lie flush in the recesses.

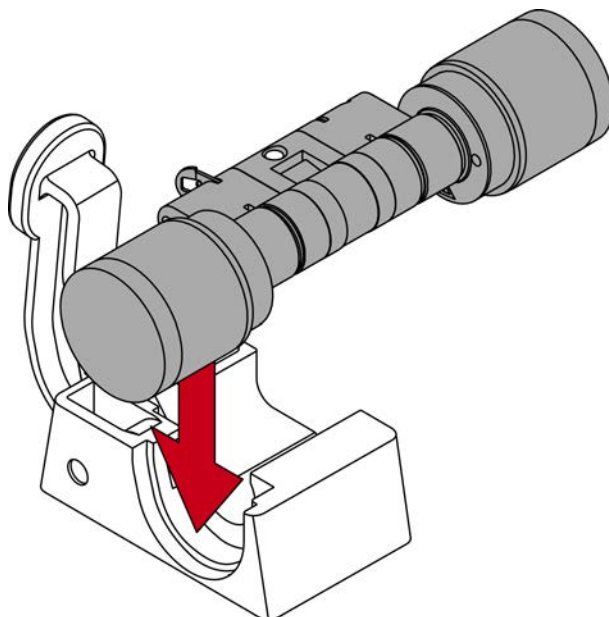

- ↳ The lever of the clamping block is reinforced at one point with a metal plate. The bracket that was previously inserted lies opposite this metal plate.

14. Push the clamp block lever towards the base plate until the clamp is fully seated in the profile cylinder.

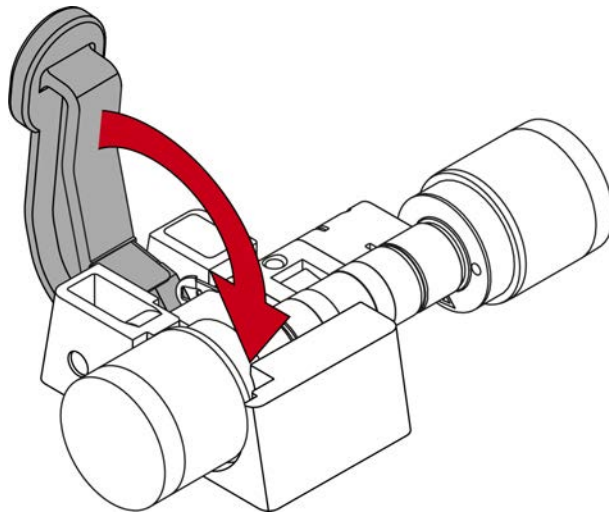

- ↳ Freely rotating cylinder fully assembled.

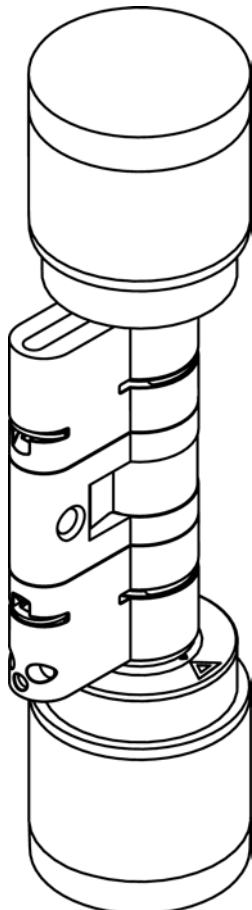

#### 10.3.4 Reduce CO cylinders to HZ

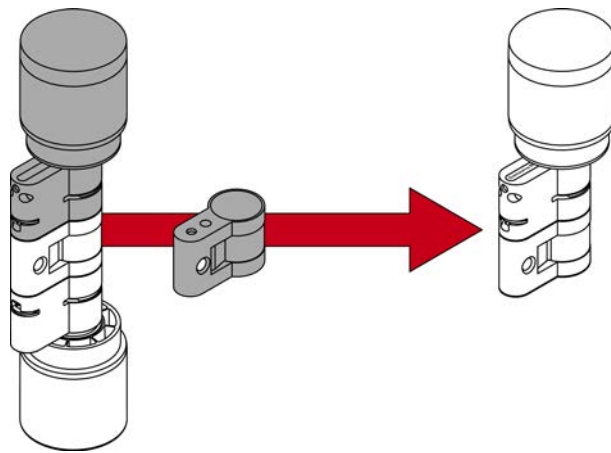

You can use a special centre piece to assemble a half cylinder from an AX comfort cylinder or a freely rotating cylinder.

- ✓ Extractor for releasing the clamp
- ✓ Spacer for aligning the extension bolt
- ✓ Clamp block for pressing in the clamp
- ✓ Half Cylinder Center Section

1. Place the Cylinder AX in the thumb-turn assembly tool with the electronic thumb-turn facing upwards.

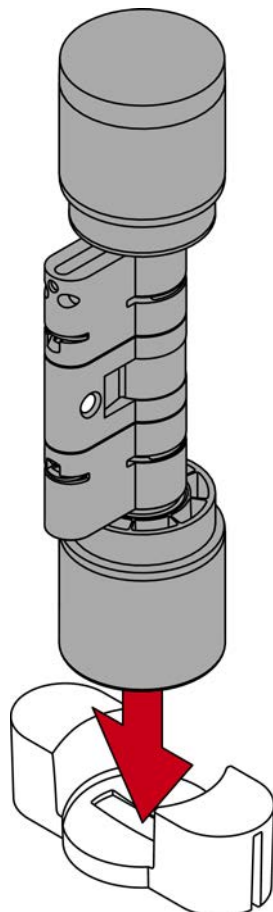



2. Hook the tip of the extractor into the clamp.

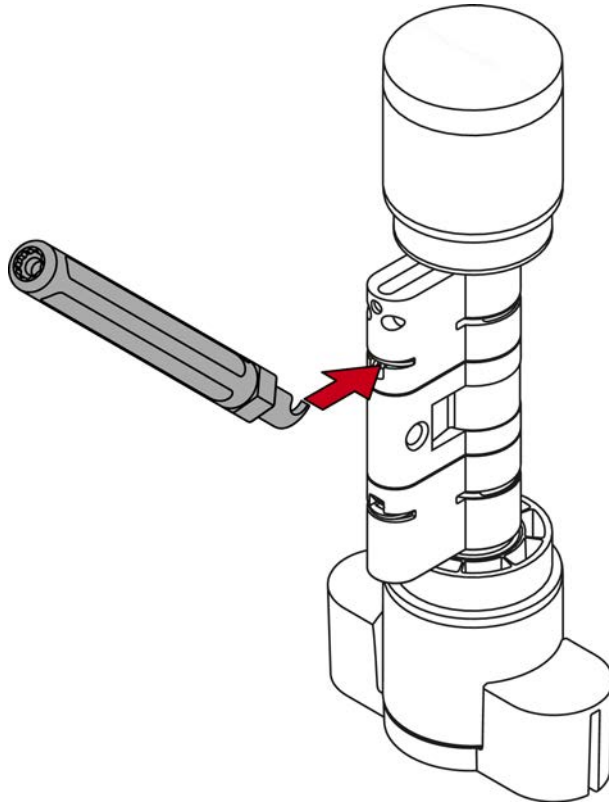

3. Lever the clamp out of the profile cylinder by moving the extractor to the centre of the cylinder.

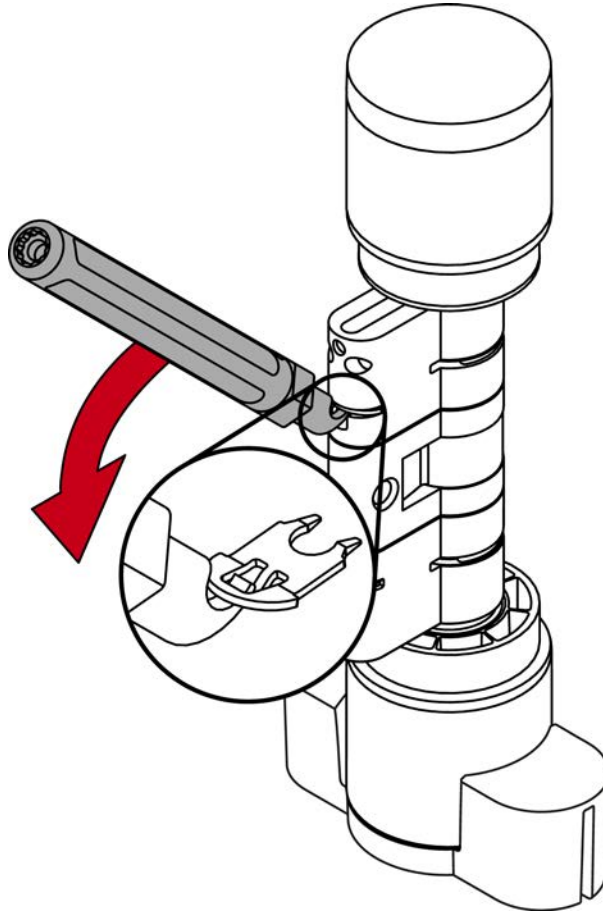

4. Pull the clamp completely out of the profile cylinder.

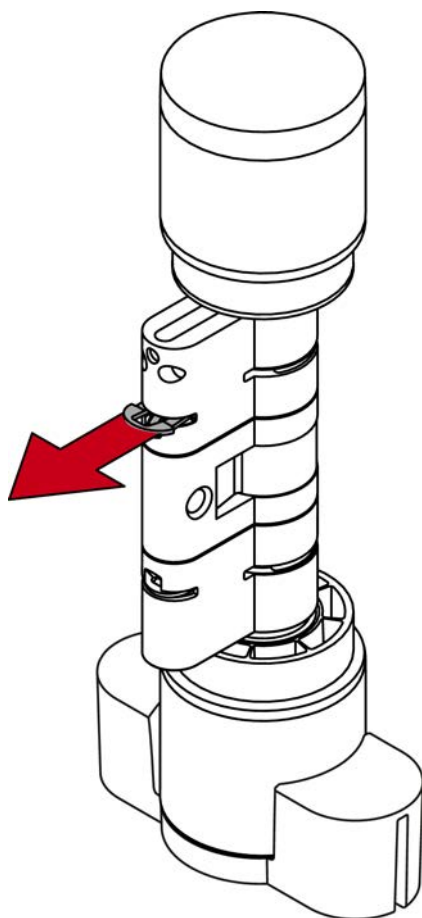

5. Disassemble the two cylinder halves.

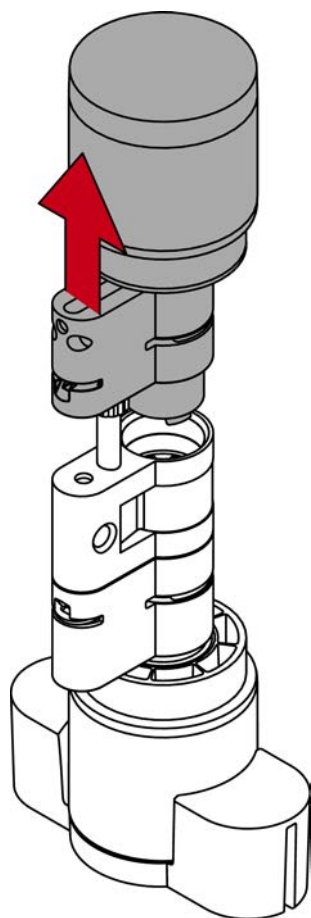

↳ First cylinder half prepared without centre piece.

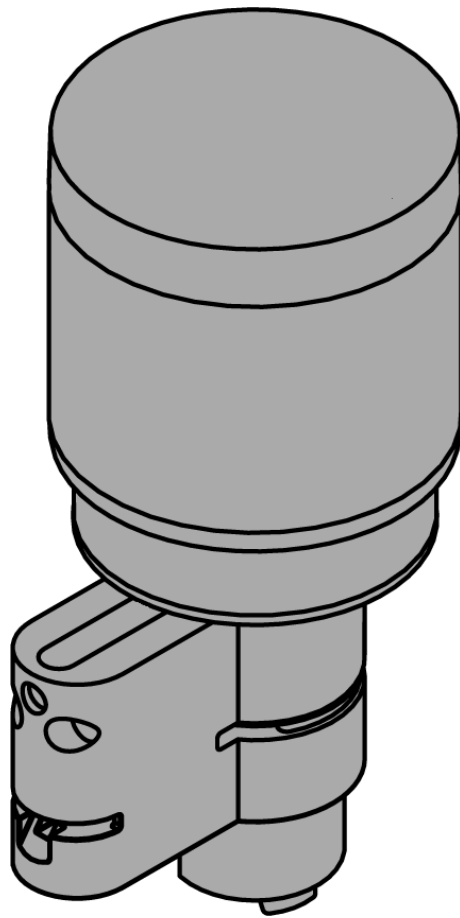

6. Place the spacer on the half-cylinder centre piece.

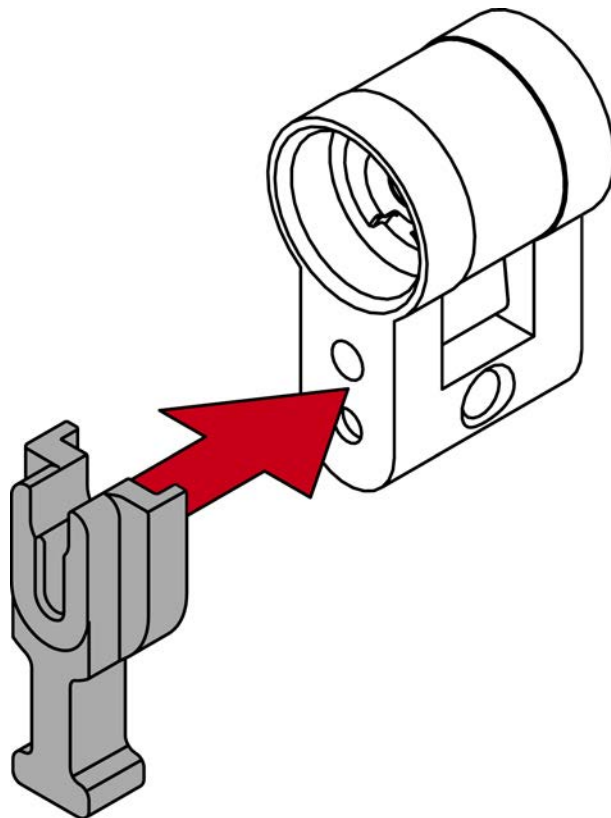

7. Screw in a suitable extension bolt with the extractor until it rests on the spacer.

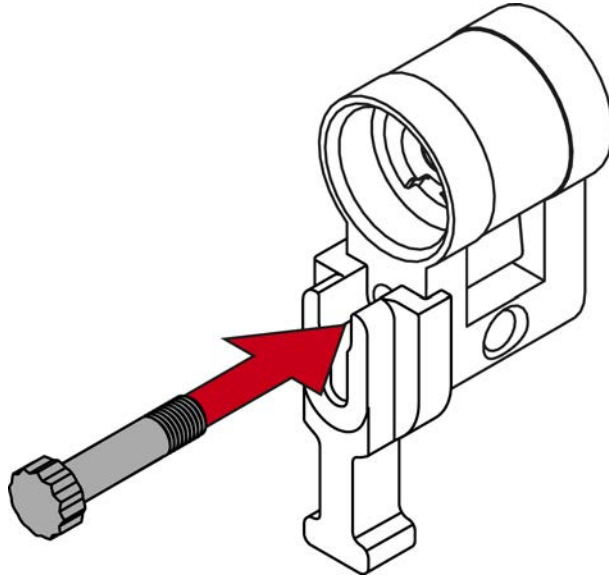

8. Place the prepared cylinder half in the thumb-turn assembly tool.

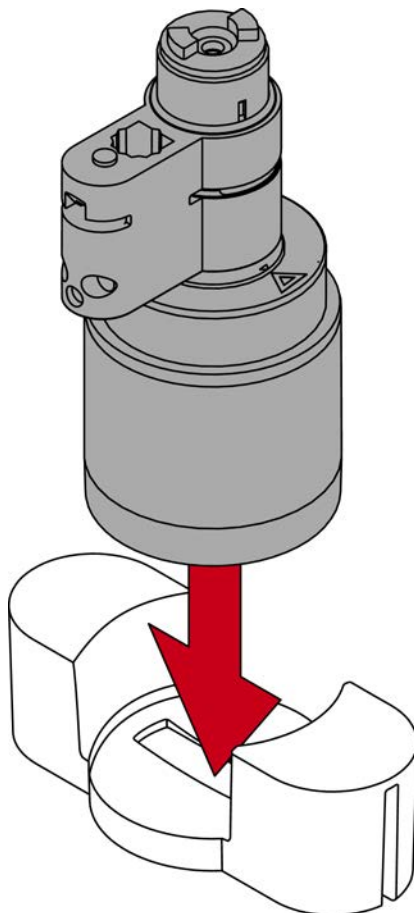

9. Place the half cylinder centre piece on the prepared cylinder half.

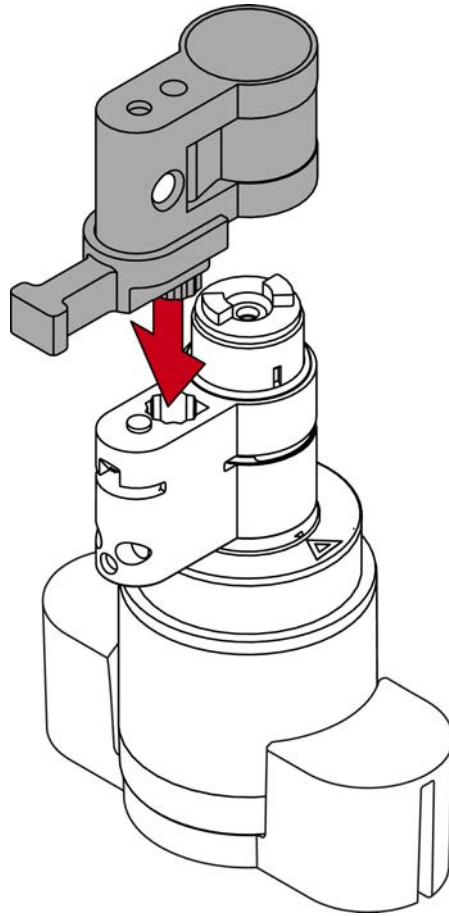

↳ Extension bolt is protected against twisting.

10. Pull the spacer off again.

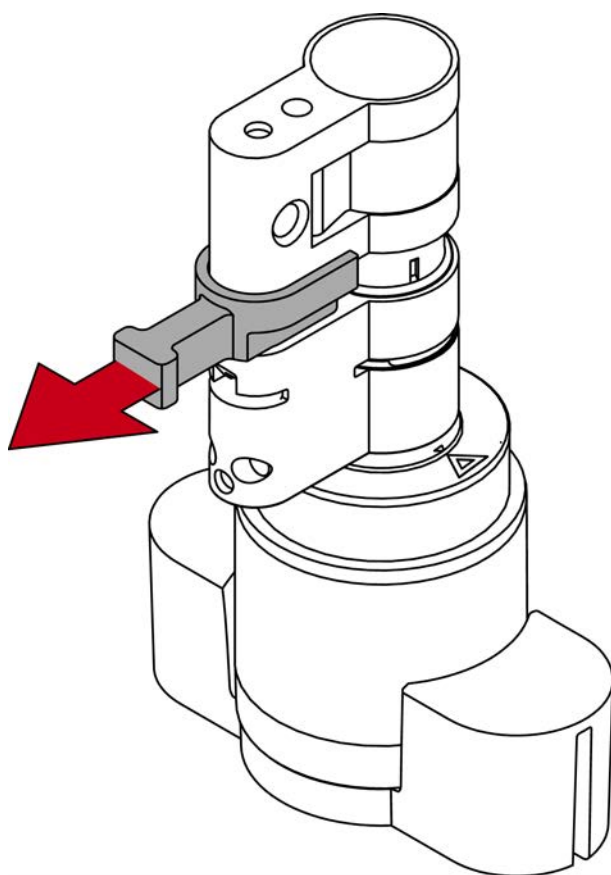



11. Push the cylinder parts together completely.

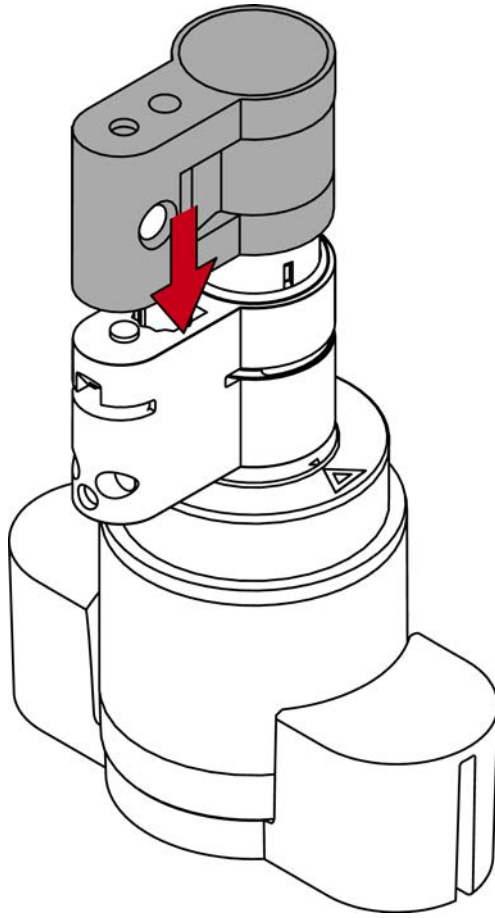

12. Refit the clip into the slot of the profile cylinder with the lug facing the fastening screw.

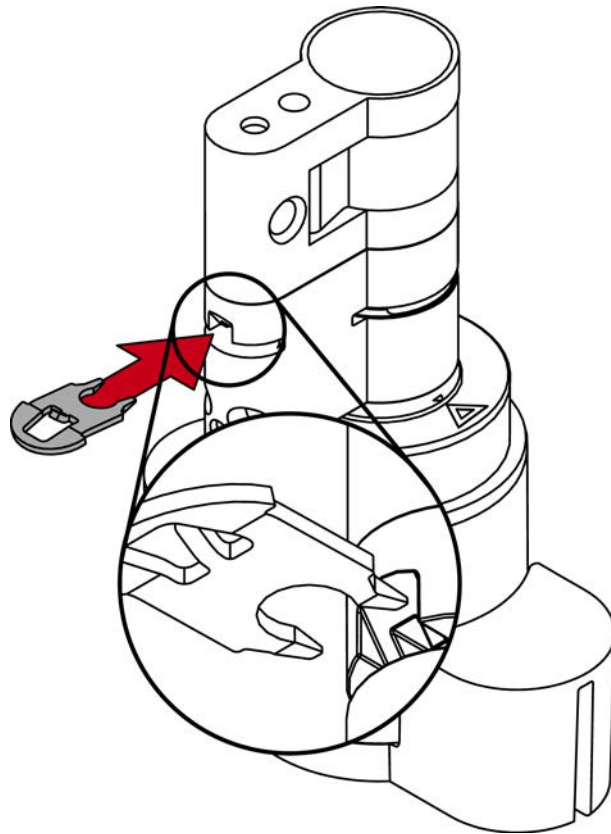

13. Insert the cylinder into the clamping block so that the profile cylinder and the thumb-turn lie flush in the recesses.

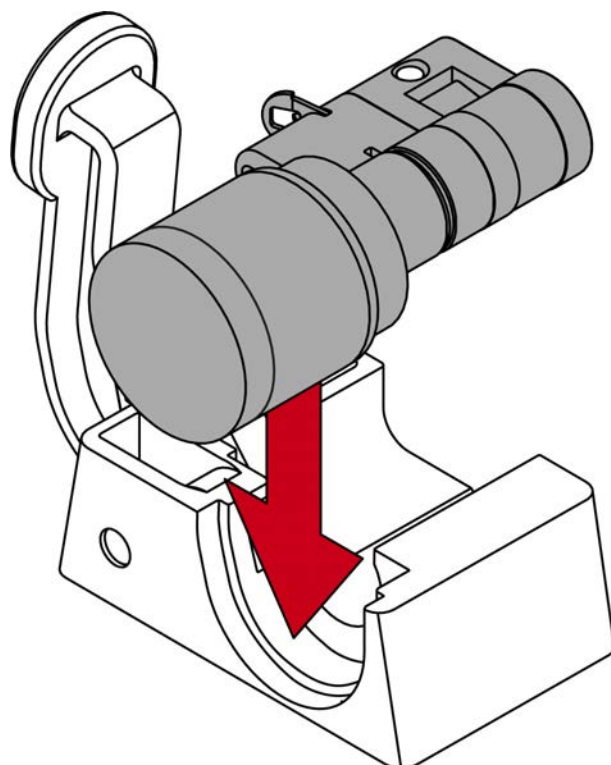

- ↳ The lever of the clamping block is reinforced at one point with a metal plate. The bracket that was previously inserted lies opposite this metal plate.

14. Push the clamp block lever towards the base plate until the clamp is fully seated in the profile cylinder.

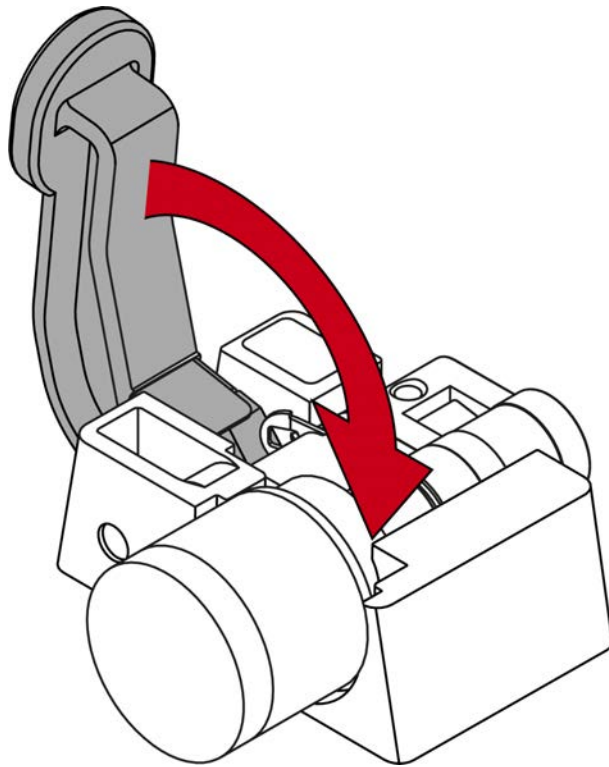

- ↳ Half cylinder AX is fully assembled.

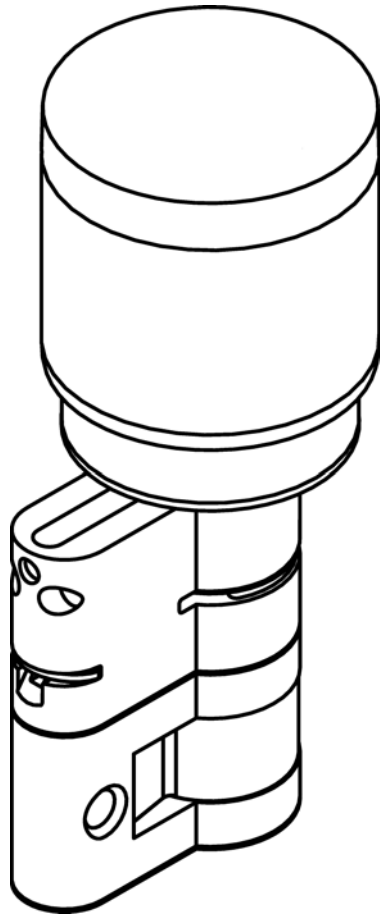

#### 10.4 Core extension

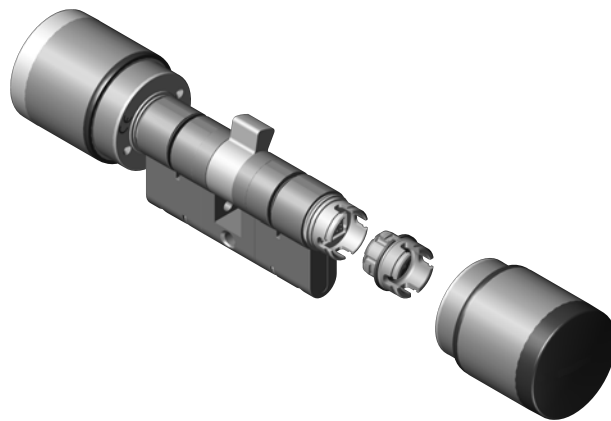

#### 10.4.1 Scope of delivery

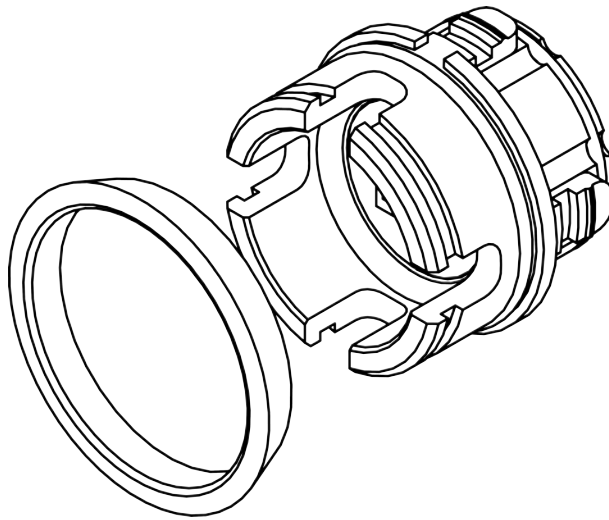

- Core extension piece with pre-assembled clamp
- Conical circlip

#### 10.4.2 Installation

##### Disassembling the electronic thumb-turn

- ✓ Special tool available.
  - ✓ 1.5 mm hexagonal wrench available.
1. Align the thumb turn horizontally.

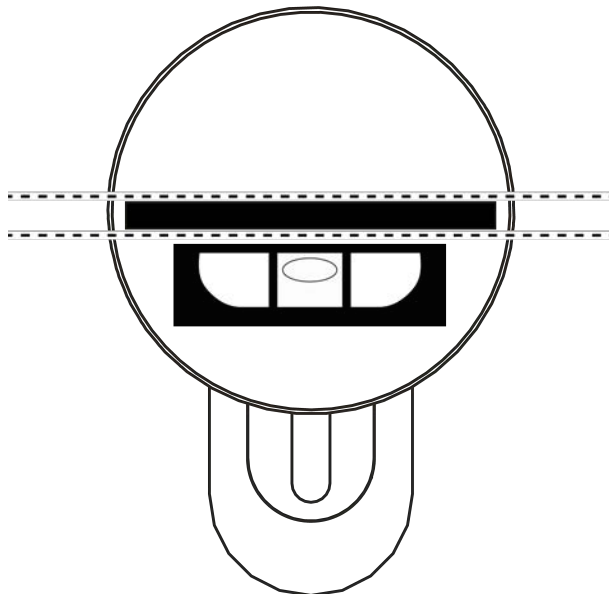

2. Attach the special tool.

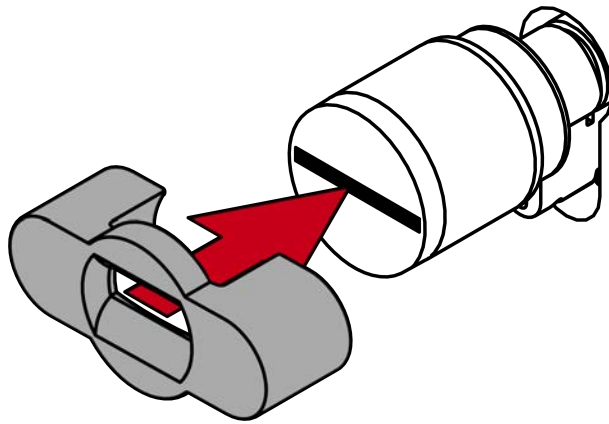

3. Align the special tool so that the logo is parallel to the recess.

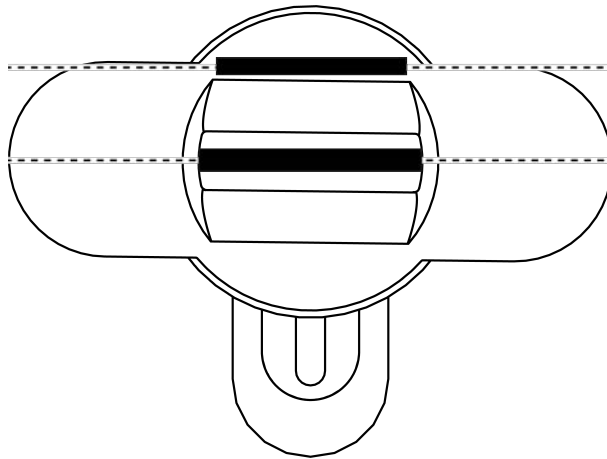

4. Hold the special tool and thumb turn cap firmly at the same time and turn them together 1-2° clockwise first and then counter-clockwise.



#### NOTE

##### Slipping when turning

The surface of the thumb turn cap can be slippery and the cap can be difficult to turn (especially with WP versions, recognizable by the blue cylinder neck ring or the lasered marking on the inner side of the cylinder profile).

- Wear non-slip gloves.

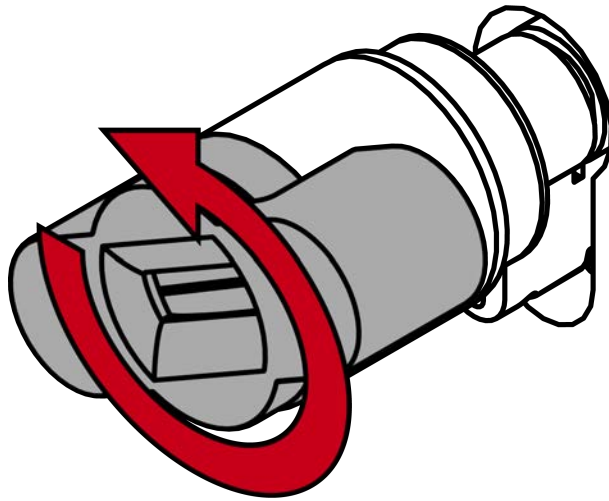

5. Remove the tool and cover.

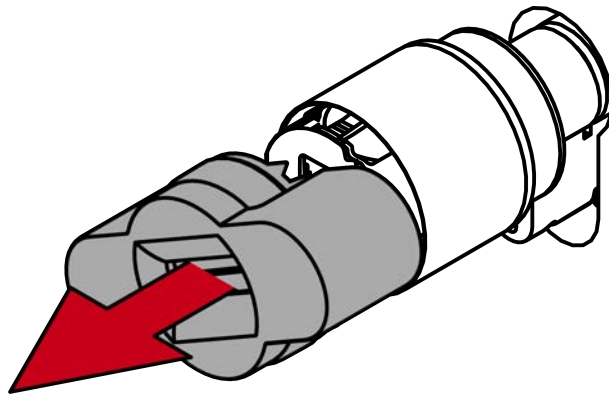

6. Insert the hexagonal wrench into the hole provided until it stops.

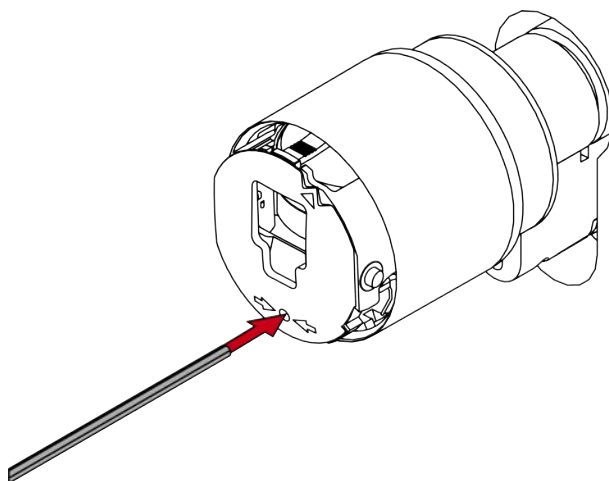

7. Turn the hex wrench 270 degrees counterclockwise.

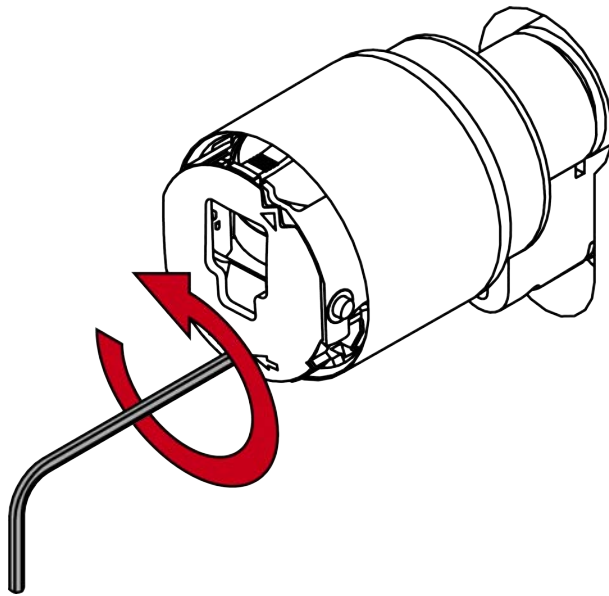

8. Pull out the hexagon wrench again.

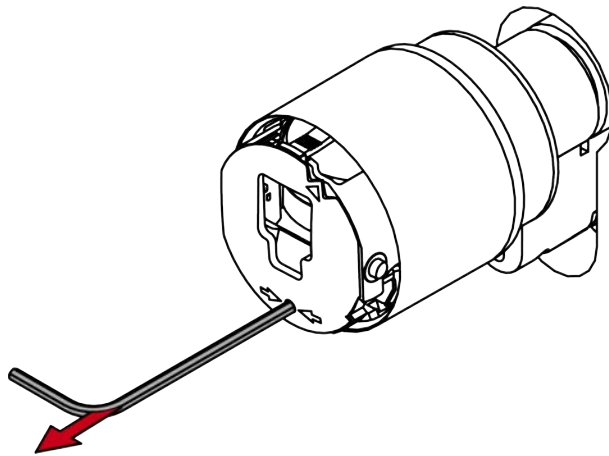



9. Pull off the thumb turn.

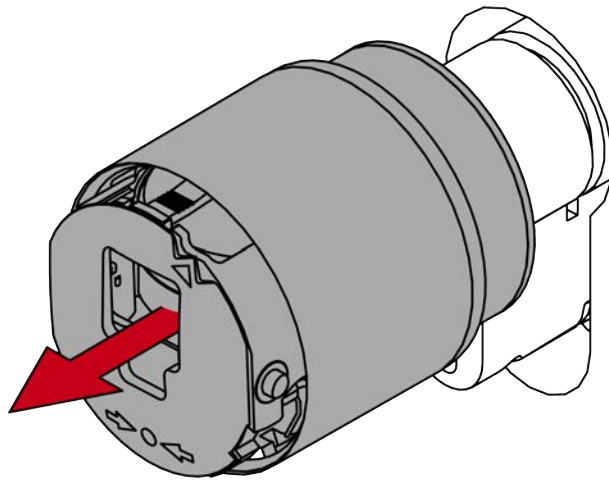

↳ Electronic thumb-turn is disassembled.

#### Insert extension

1. Pull the centering bush out of the thumb-turn mount.

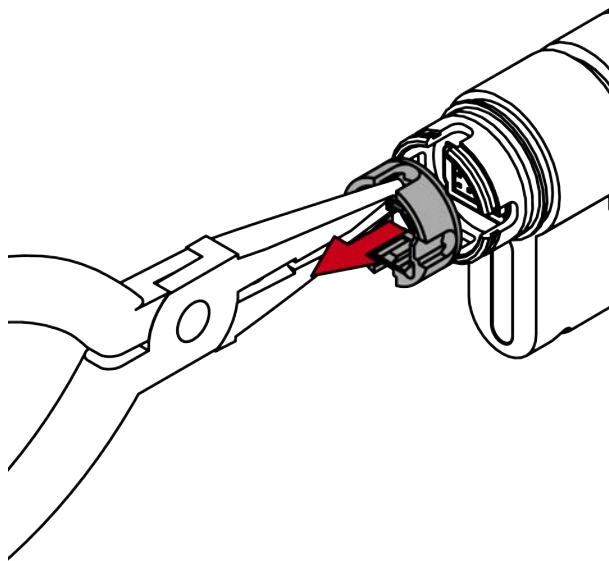

2. Insert the extension piece into the thumb-turn mount.

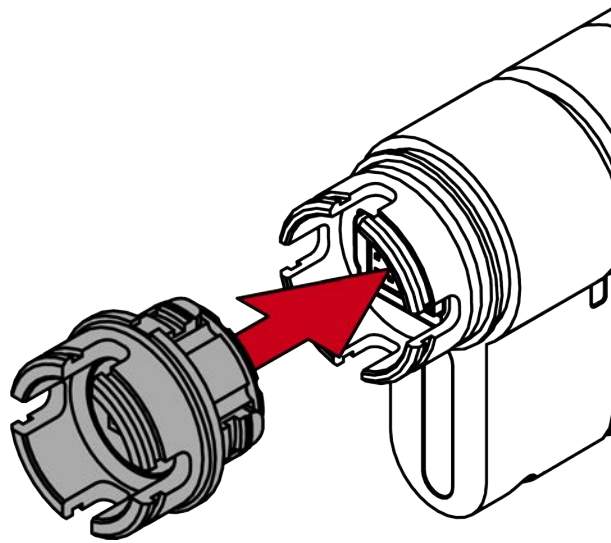

### IMPORTANT

#### Damage due to incorrect alignment

The extension piece or its contact pins cannot be inserted if installed incorrectly.

- Check alignment of contact pins.

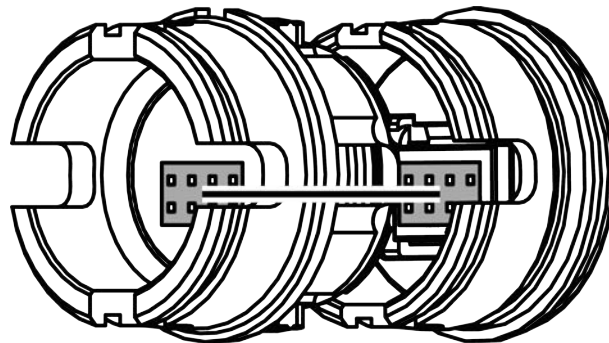

3. Slide the pre-assembled clamp from the extension piece towards the driver until it slides into the groove provided.

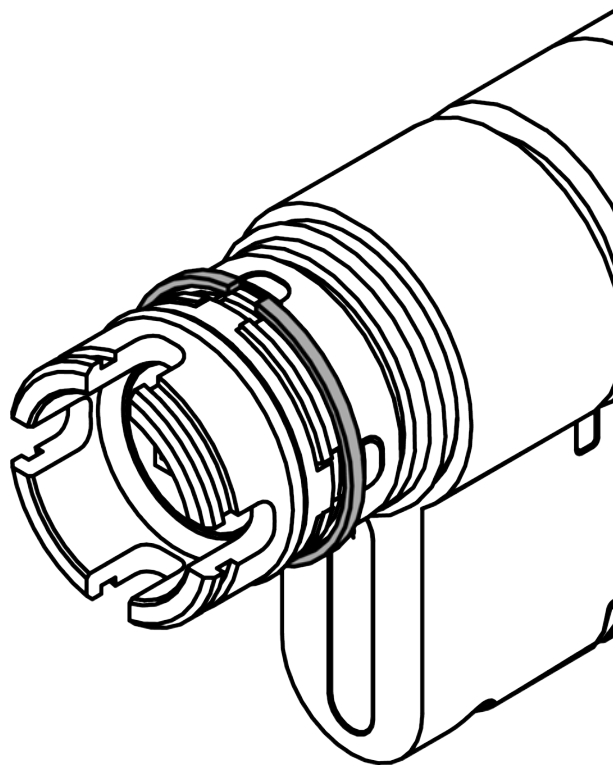
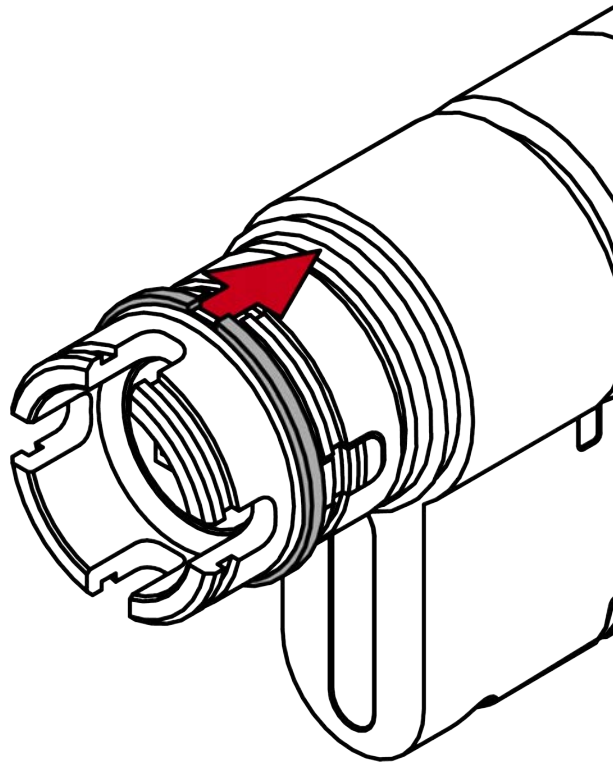

4. Push the circlip with the smaller diameter in the direction of the driver onto the thumb-turn mount as far as it will go.

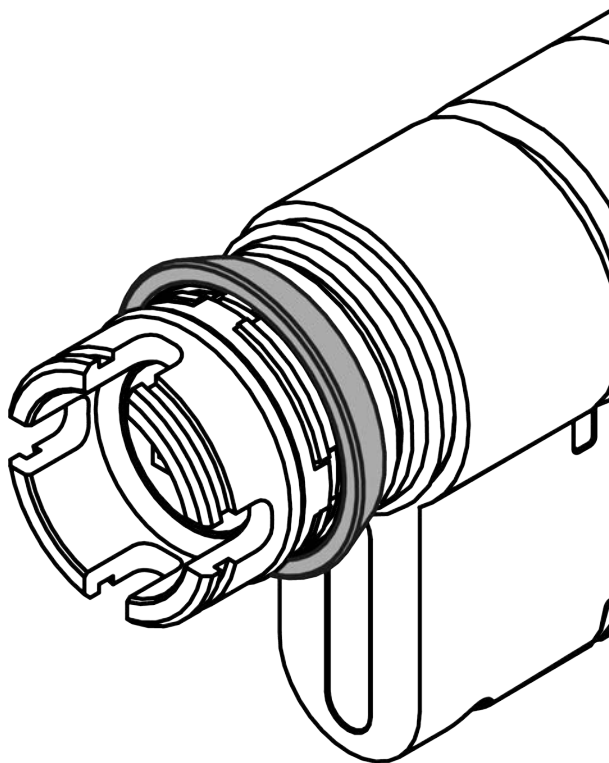
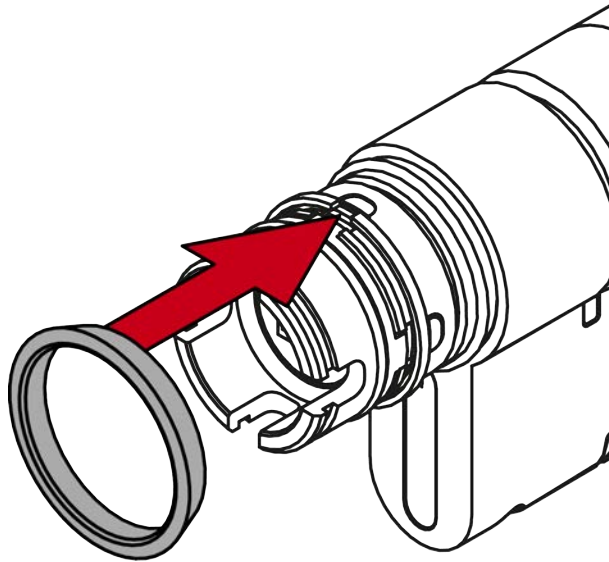

↳ The clamp can no longer slip.

### Installing the electronic thumb-turn

✓ 1.5 mm hexagonal wrench available.

1. Align the thumb turn mount horizontally.

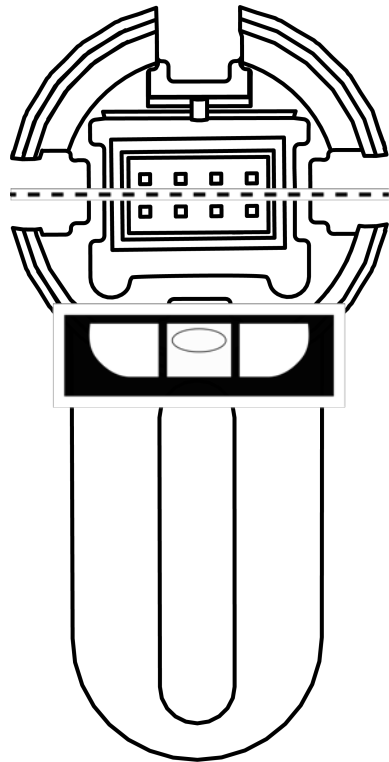

2. Attach the thumb turn.

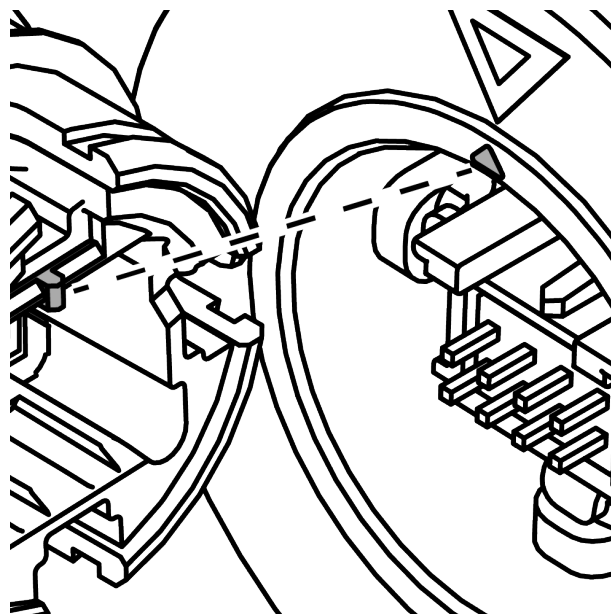

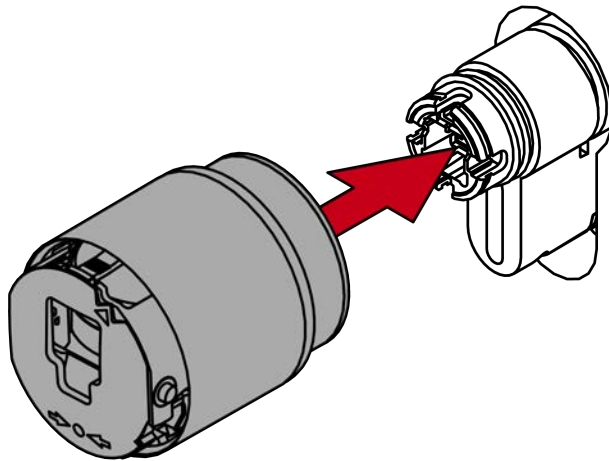

**NOTE**

Use the supplied hexagonal wrench.

The special tool is supplied with a hexagonal wrench.

- Use this hexagonal wrench to mount and dismount the electronic thumb turn.

3. Insert the hexagonal wrench into the hole provided until it stops.

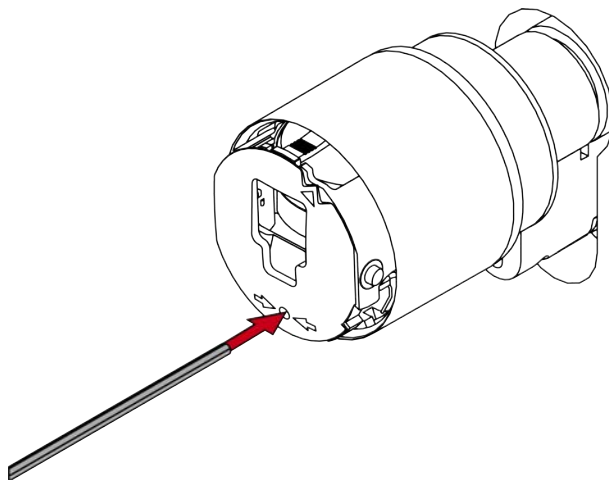

4. Turn the hex key 270 degrees clockwise.

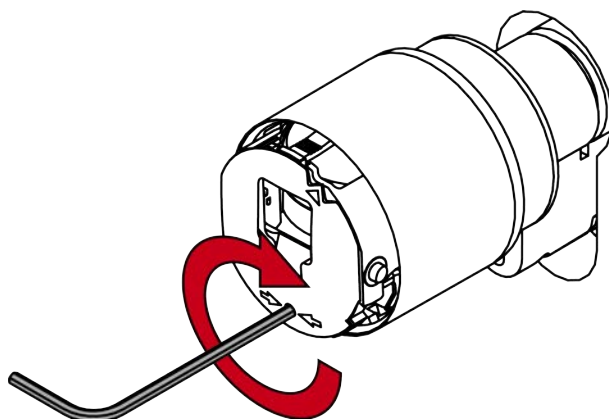

5. Pull out the hexagon wrench again.

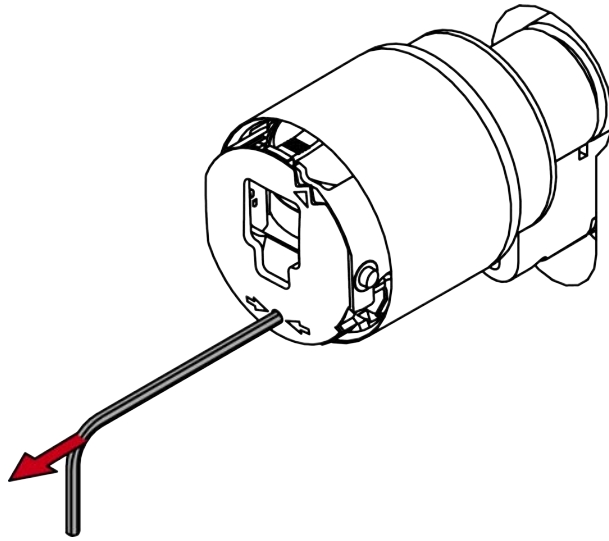

6. Put on the cover.

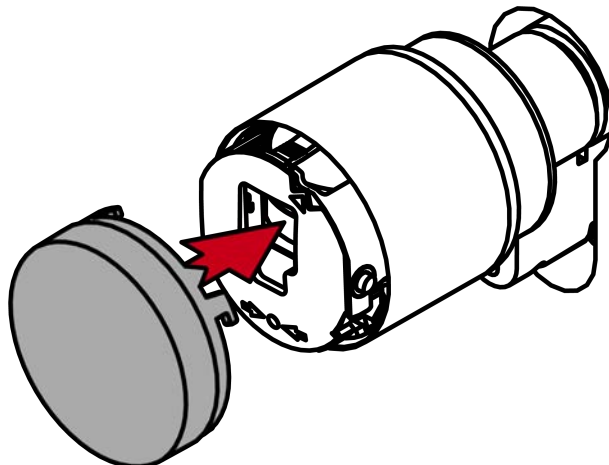
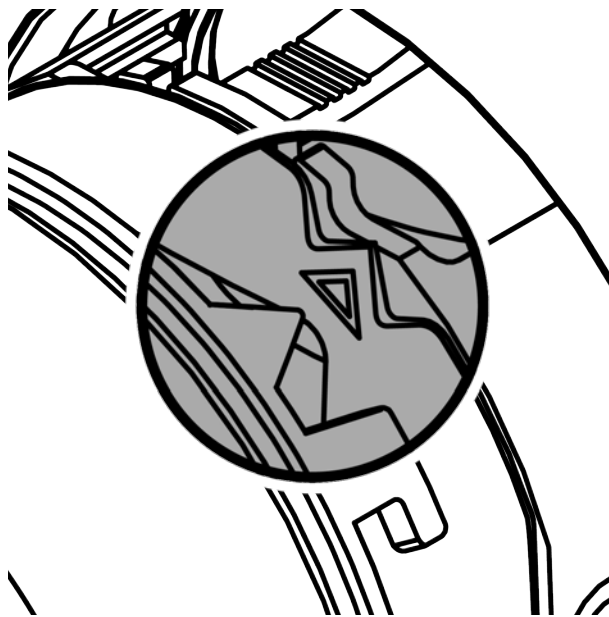

7. Turn the cover clockwise.

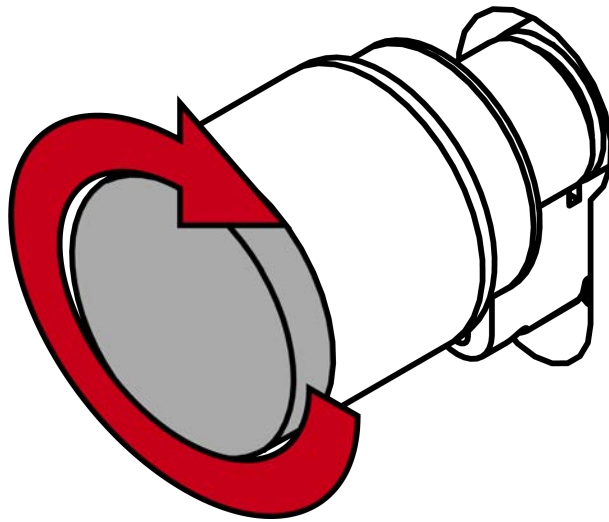

- ↳ The cover snaps into place with one click.
- ↳ The electronic thumb turn is installed.

## 10.5 Escape knob

### 10.5.1 Installation on fitted cylinder (clockwise unlocking)

#### Removing the mechanical thumb-turn

- ✓ Special tool available.

1. Align the thumb turn horizontally.

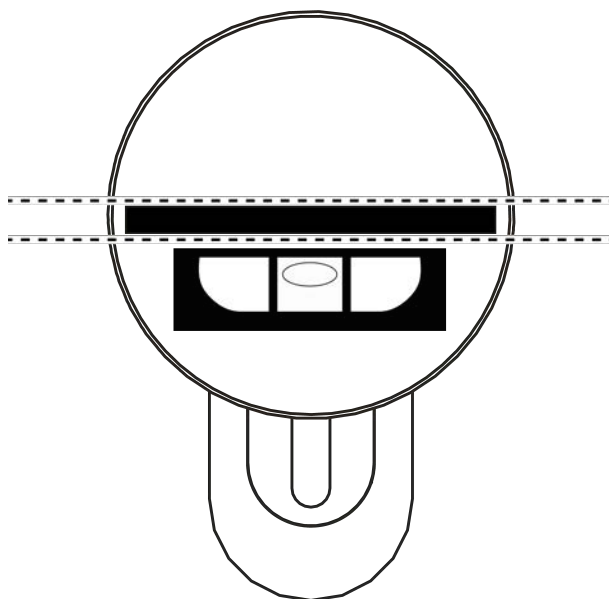



2. Attach the special tool.

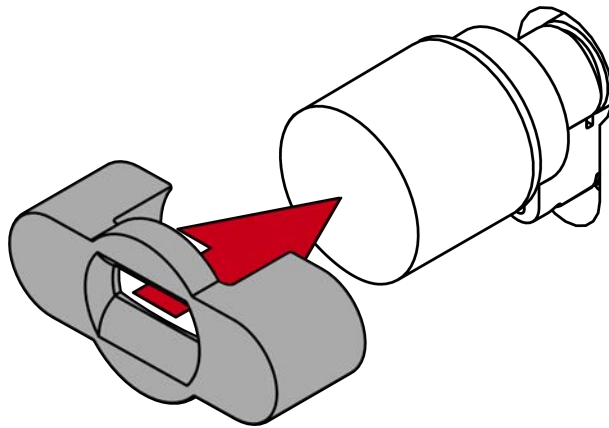

3. Align the special tool so that the logo is parallel to the recess.

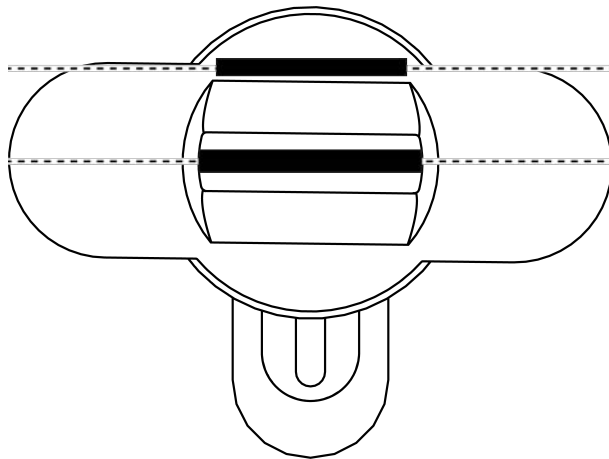

4. At the same time turn the special tool and the thumb turn counter-clockwise.

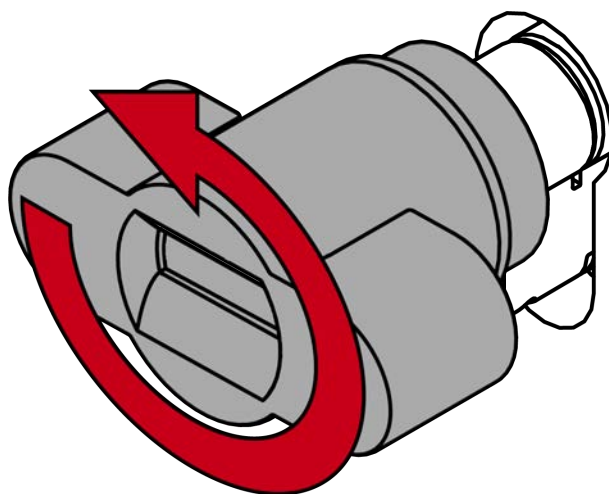

5. Remove the special tool and the thumb turn at the same time.

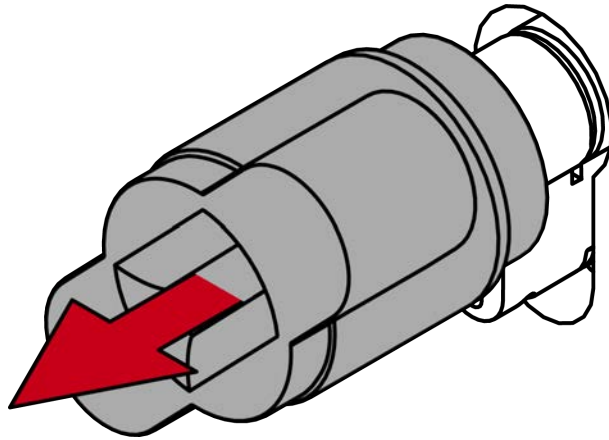

- ↳ The mechanical thumb turn is disassembled.

#### Installing the escape thumb-turn

- ✓ 1.5 mm hexagonal wrench available.

1. Insert the 1.5 mm hex key into the escape thumb turn.

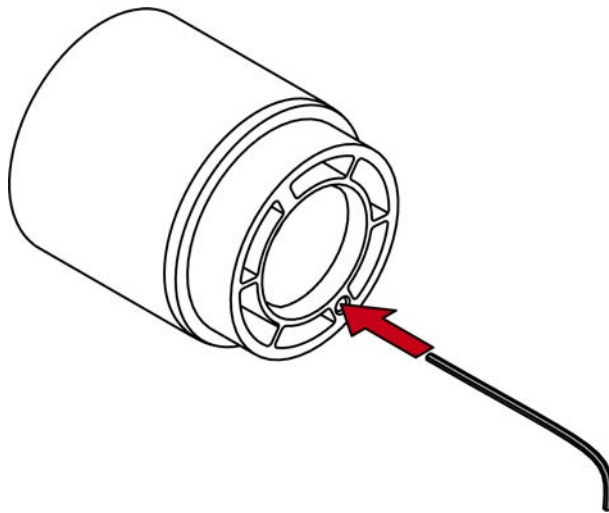

2. Turn the hex key fully clockwise until it comes to a stop.
  - ↳ Escape thumb turn clicks.

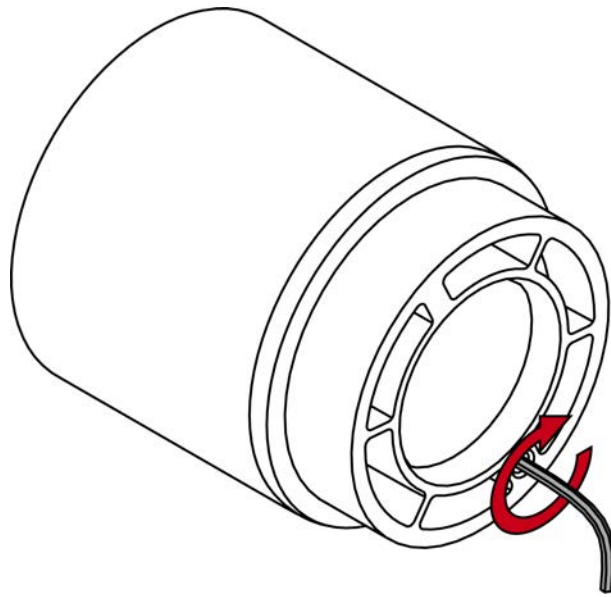

3. Pull out the hexagon wrench again.
4. Place the escape thumb turn on the cylindrical shaft.

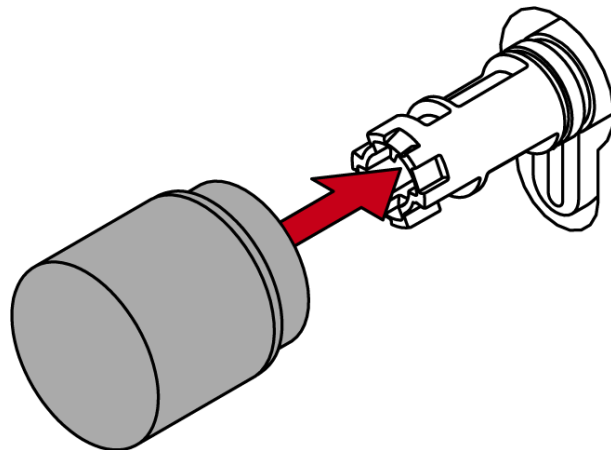

5. Turn the escape thumb-turn clockwise until it engages.

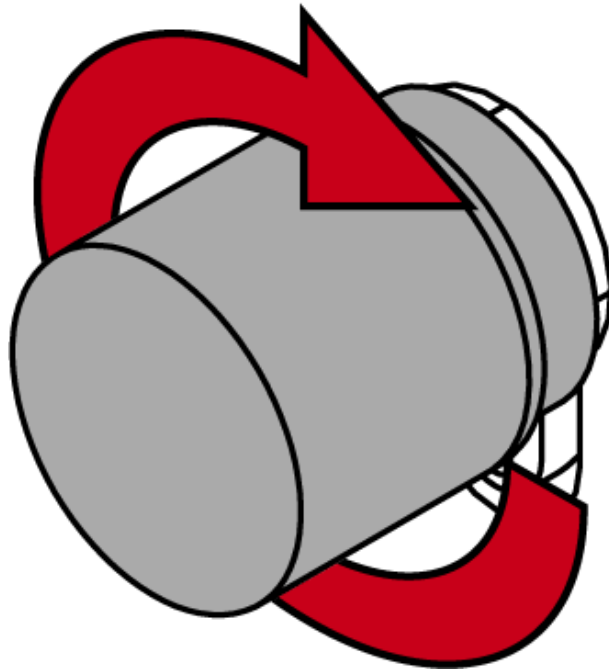

#### Functional test

1. Turn and pull the escape thumb-turn to check that it is properly locked in position.
  2. Check that you can unlock the door with the escape thumb-turn.
- ↳ Escape thumb turn is installed.

### 10.5.2 Installation on the removed cylinder (anticlockwise unlocking)

#### Removing the mechanical thumb-turn

- ✓ Special tool available.
- 1. Align the thumb turn horizontally.

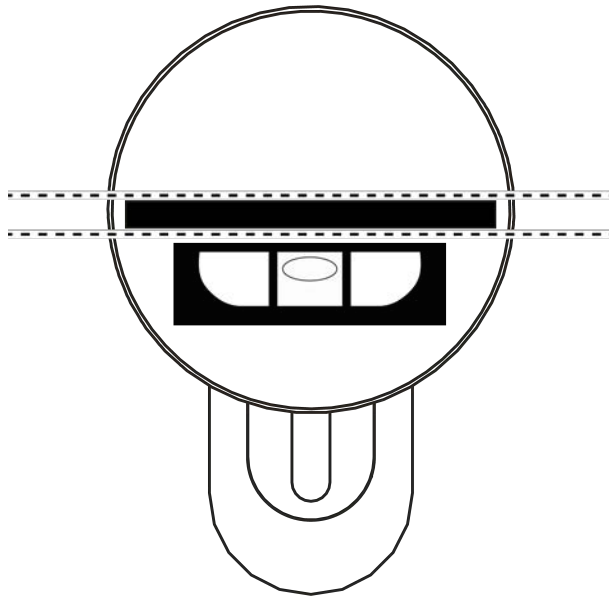

- 2. Attach the special tool.

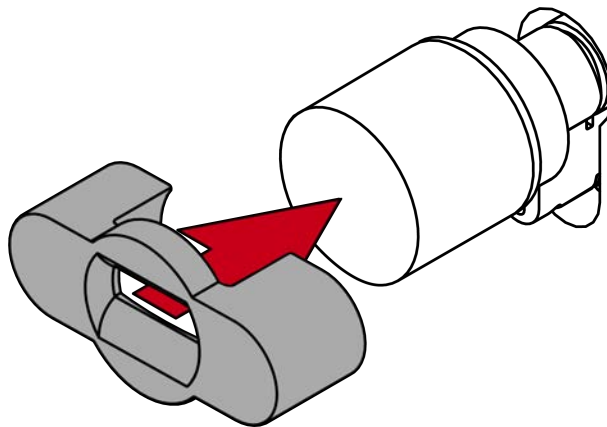

3. Align the special tool so that the logo is parallel to the recess.

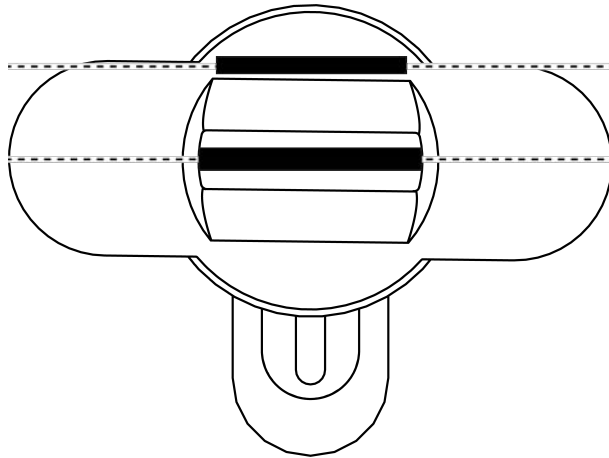

4. At the same time turn the special tool and the thumb turn counter-clockwise.

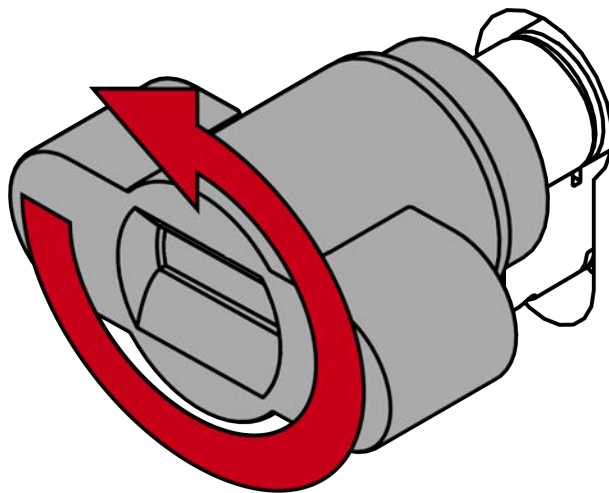

5. Remove the special tool and the thumb turn at the same time.

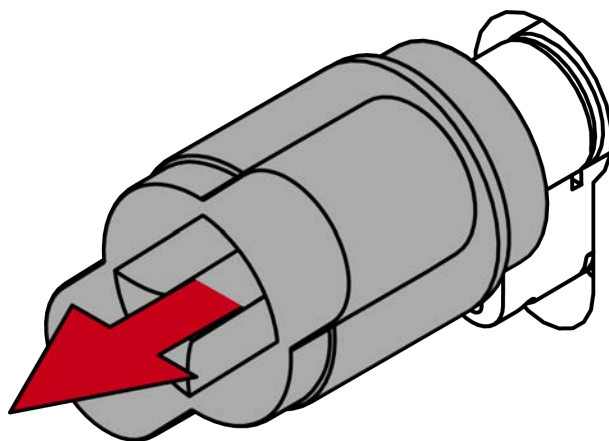

↳ The mechanical thumb turn is disassembled.

### Removing the cylinder

1. Unscrew the fastening screw.

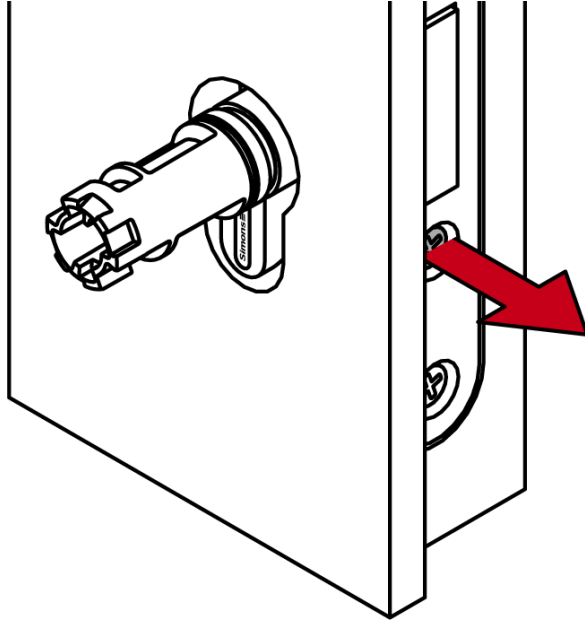

2. Remove the cylinder.

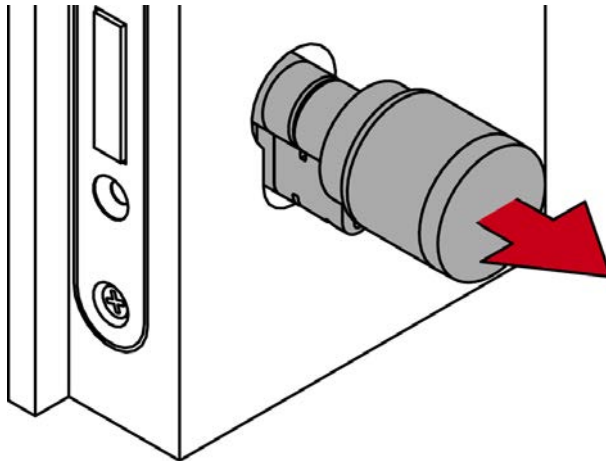

### Disassembling the electronic thumb-turn

- ✓ Special tool available.
- ✓ 1.5 mm hexagonal wrench available.

1. Align the thumb turn horizontally.

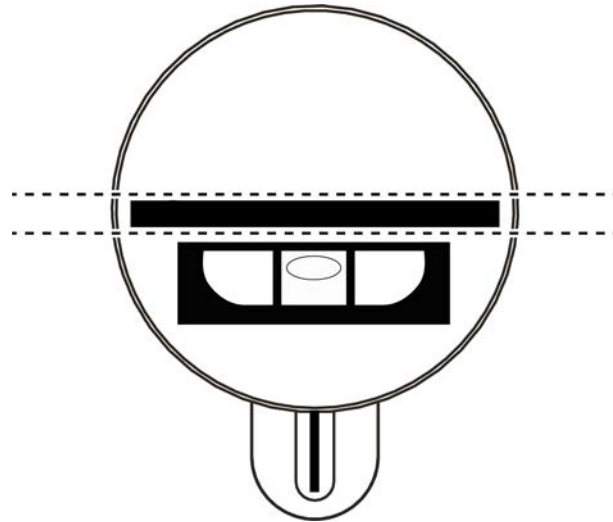

2. Attach the special tool.

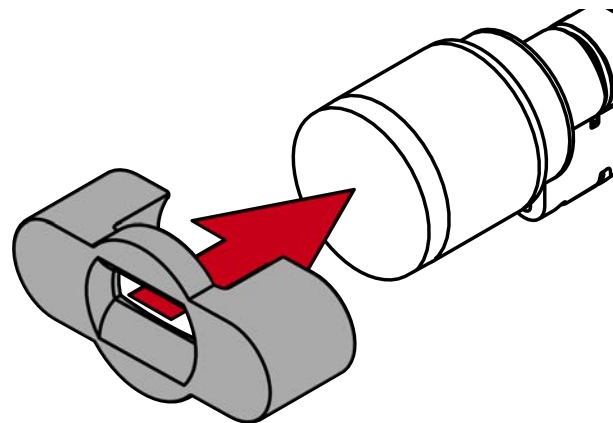

3. Align the special tool so that the logo is parallel to the recess.

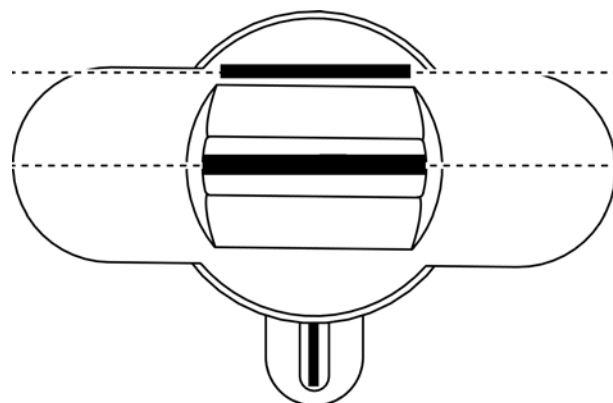



4. Hold the special tool and thumb turn cap firmly at the same time and turn them together 1-2° clockwise first and then counter-clockwise.



#### NOTE

##### Slipping when turning

The surface of the thumb turn cap can be slippery and the cap can be difficult to turn (especially with WP versions, recognizable by the blue cylinder neck ring or the lasered marking on the inner side of the cylinder profile).

- Wear non-slip gloves.

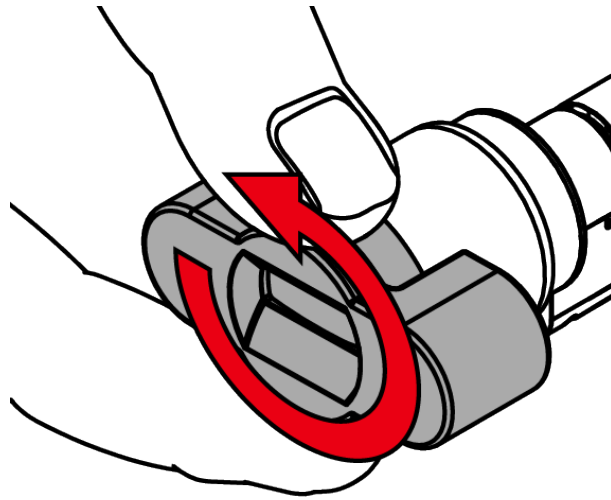

5. Remove the tool and cover.

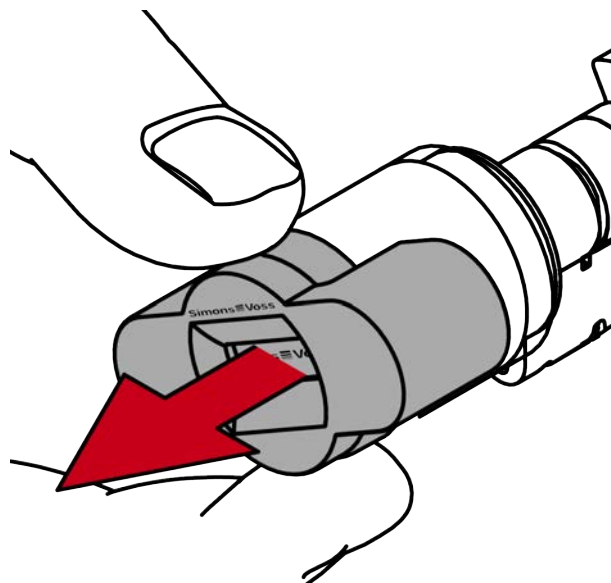

6. Insert the hexagonal wrench into the hole provided until it stops.

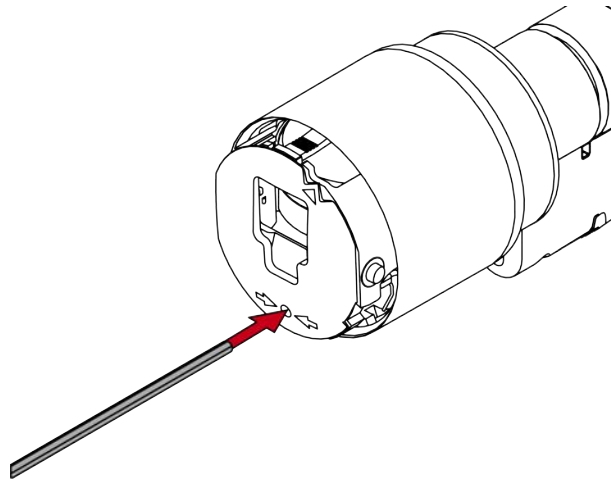

7. Turn the hex wrench 270 degrees counterclockwise.

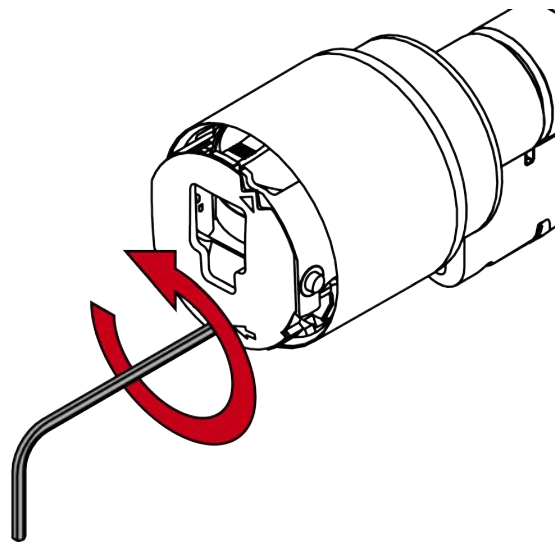

8. Pull out the hexagon wrench again.

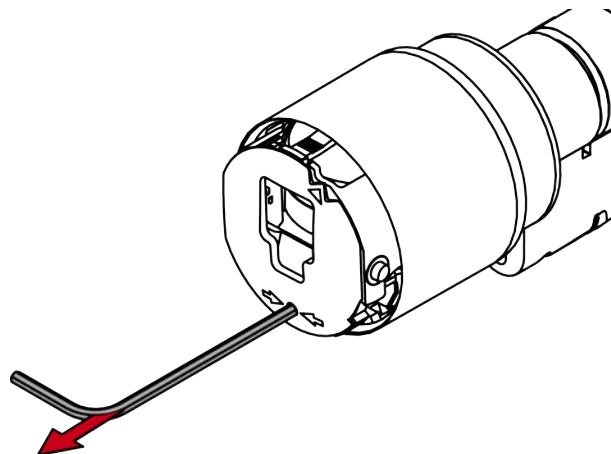

9. Pull off the thumb turn.

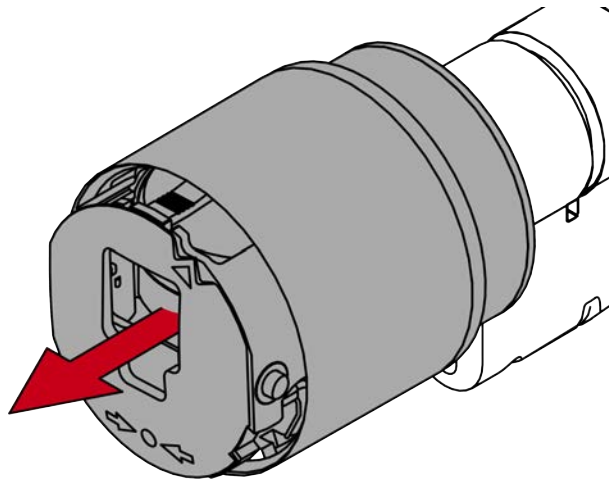

↳ Electronic thumb turn is disassembled.

#### Installing the escape thumb-turn

✓ 1.5 mm hexagonal wrench available.

1. Insert the 1.5 mm hex key into the escape thumb turn.

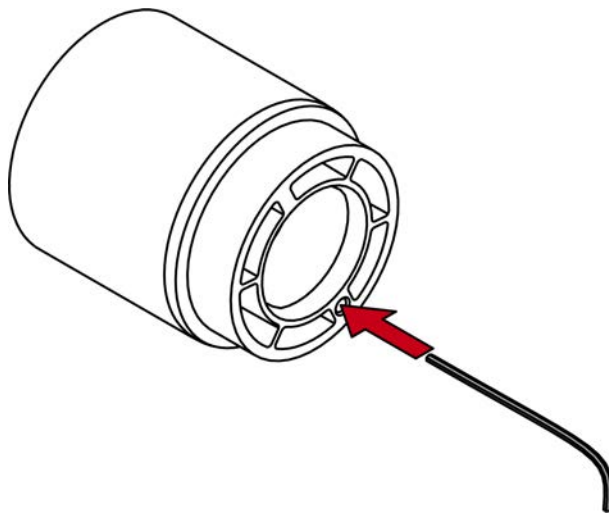

2. Turn the hex key fully clockwise until it comes to a stop.

↳ Escape thumb turn clicks.

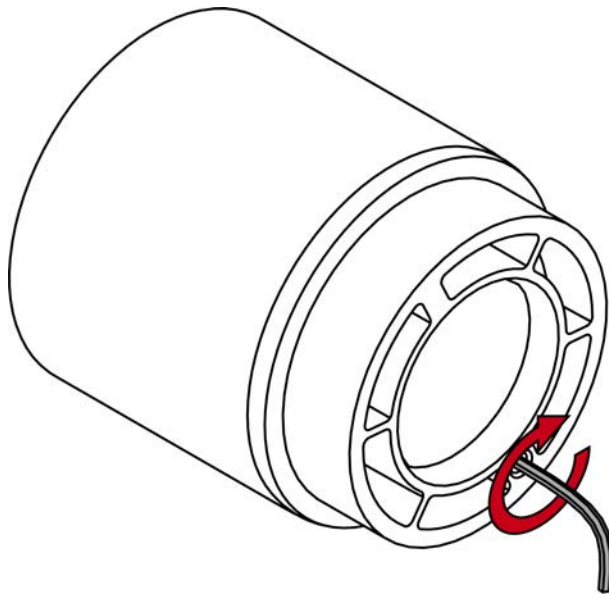

3. Pull out the hexagon wrench again.
4. Place the escape thumb turn on the cylindrical shaft.

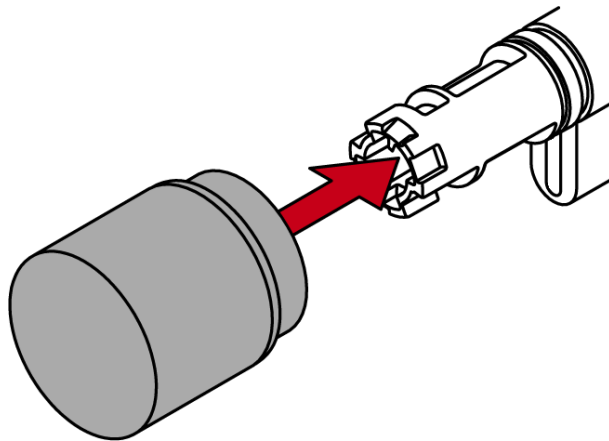

5. Hold the cam firmly and turn the escape thumb-turn clockwise until it stops.

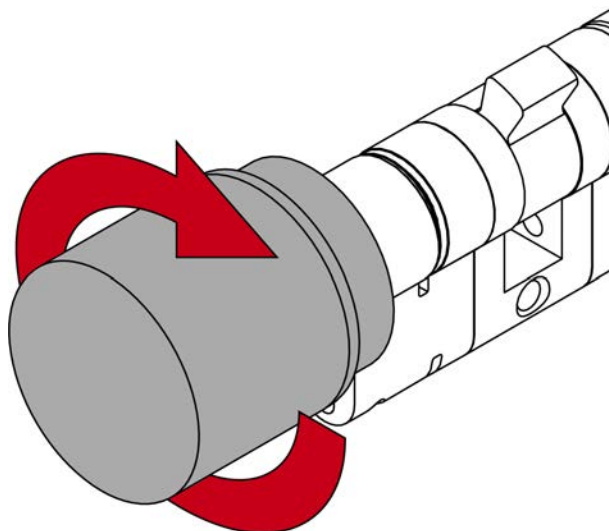

6. Insert the 1.5 mm hex key into the escape thumb turn.

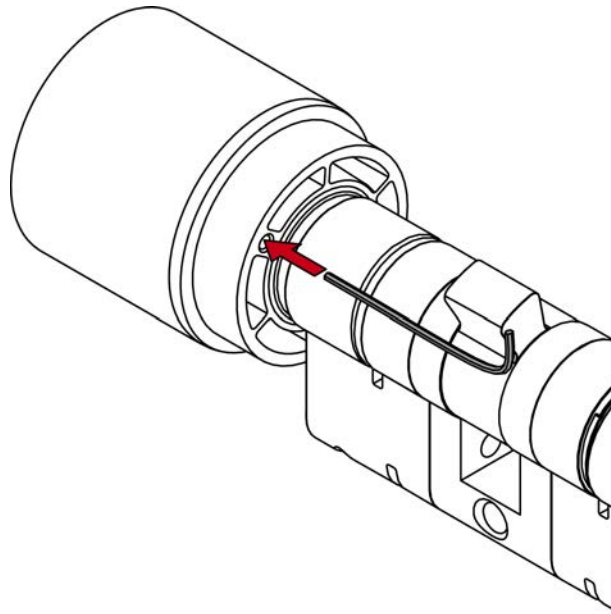

7. Turn the 1.5 mm hex key fully counter-clockwise until it will go no further.  
↳ Escape thumb turn clicks.

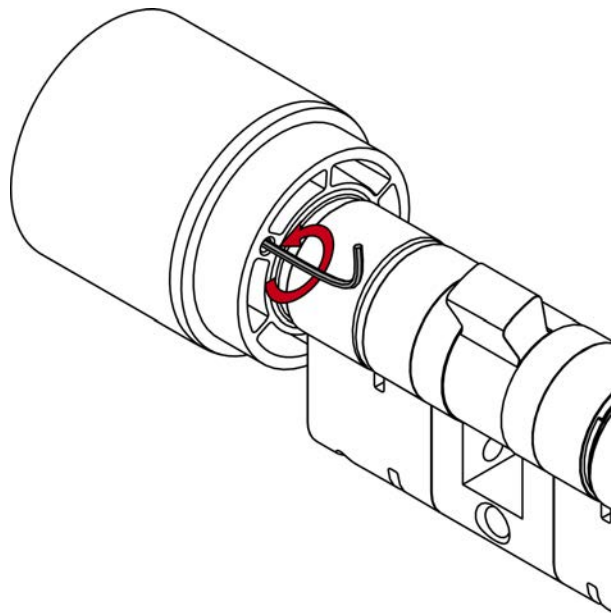

8. Reinstall the cylinder.

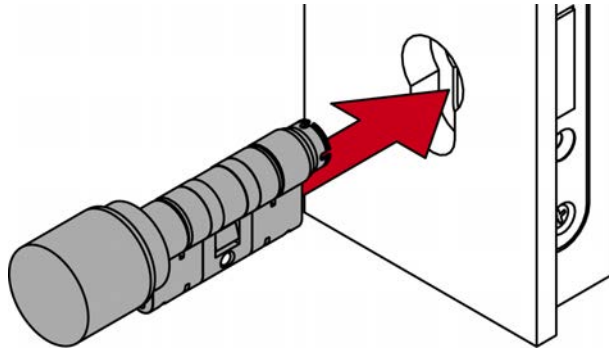

9. Tighten the fastening screw.

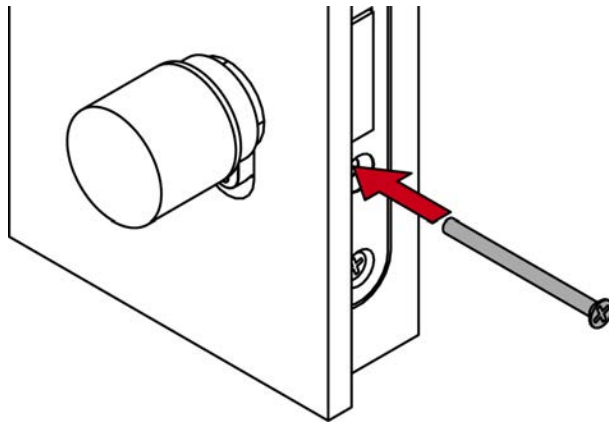

### Re-fitting the electronic thumb-turn

✓ 1.5 mm hexagonal wrench available.

1. Align the thumb turn mount horizontally.

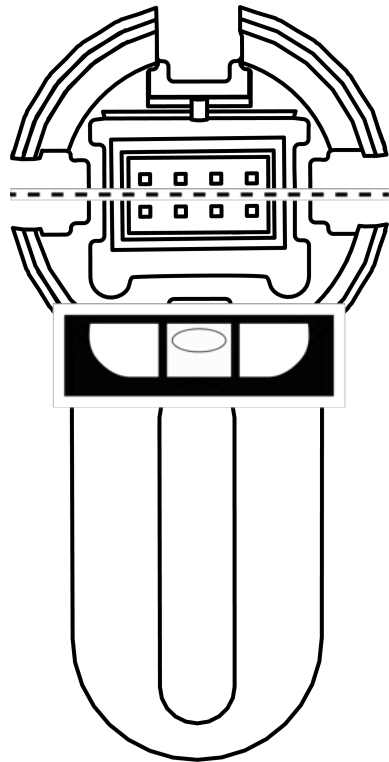

2. Attach the thumb turn.

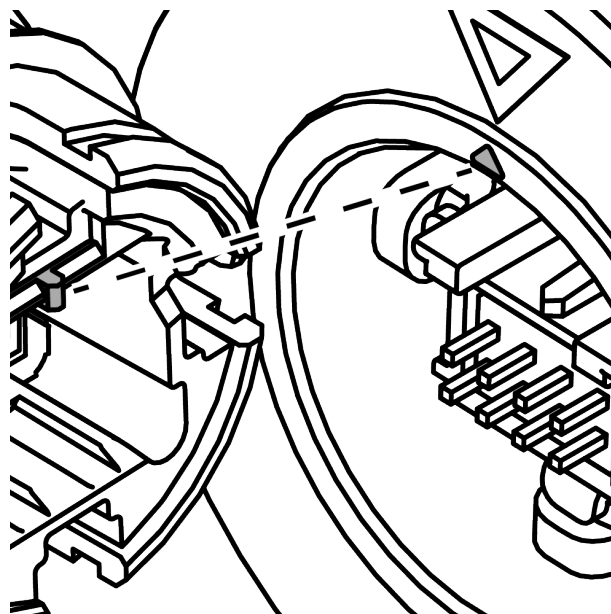

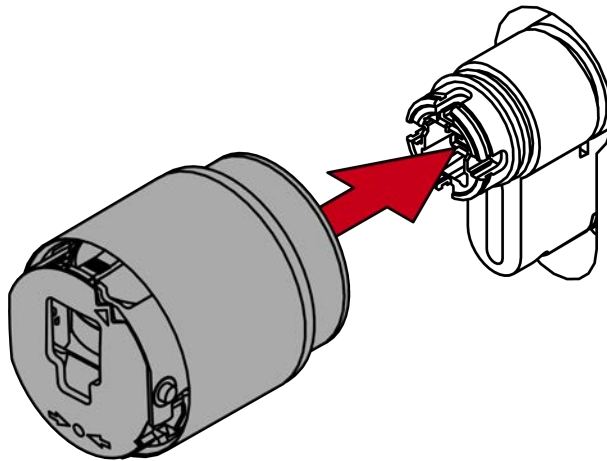

**NOTE**

Use the supplied hexagonal wrench.

The special tool is supplied with a hexagonal wrench.

- Use this hexagonal wrench to mount and dismount the electronic thumb turn.

3. Insert the hexagonal wrench into the hole provided until it stops.

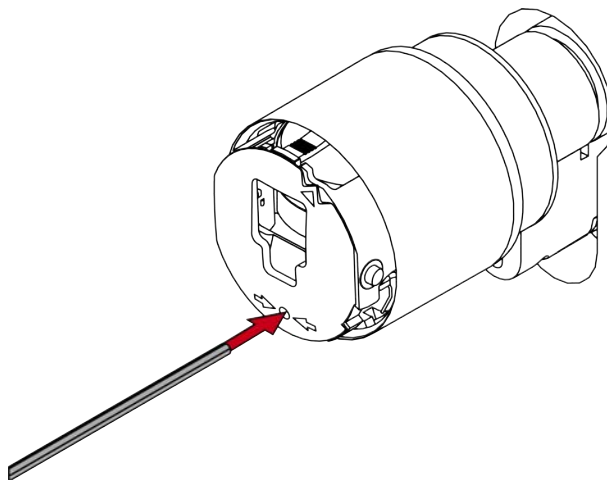

4. Turn the hex key 270 degrees clockwise.

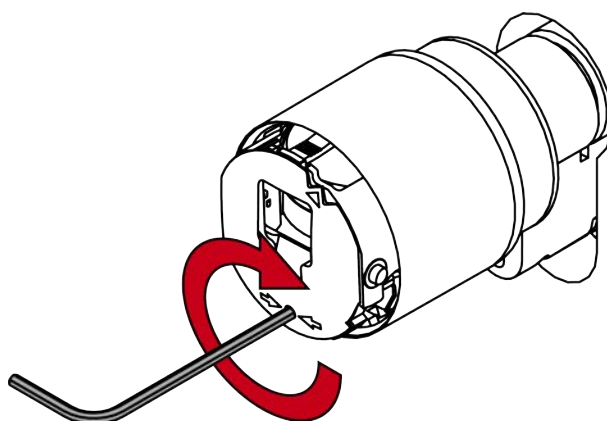



5. Pull out the hexagon wrench again.

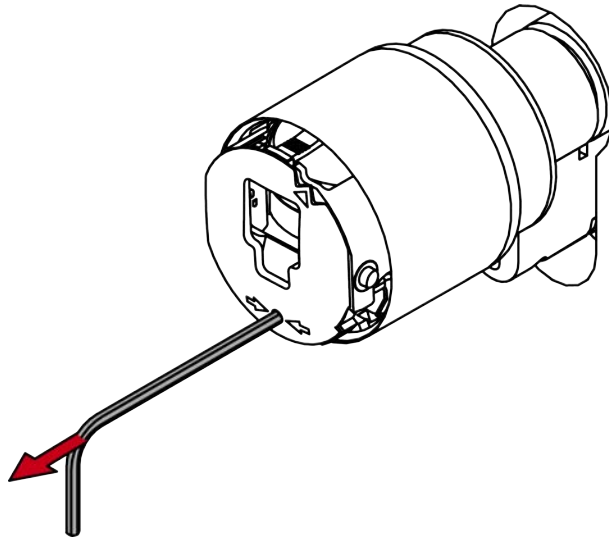

6. Put on the cover.

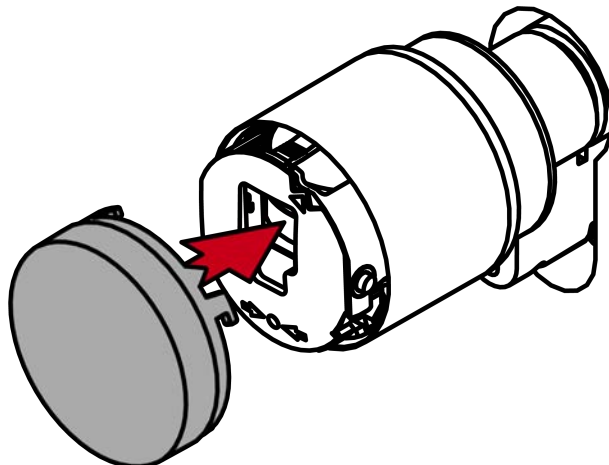
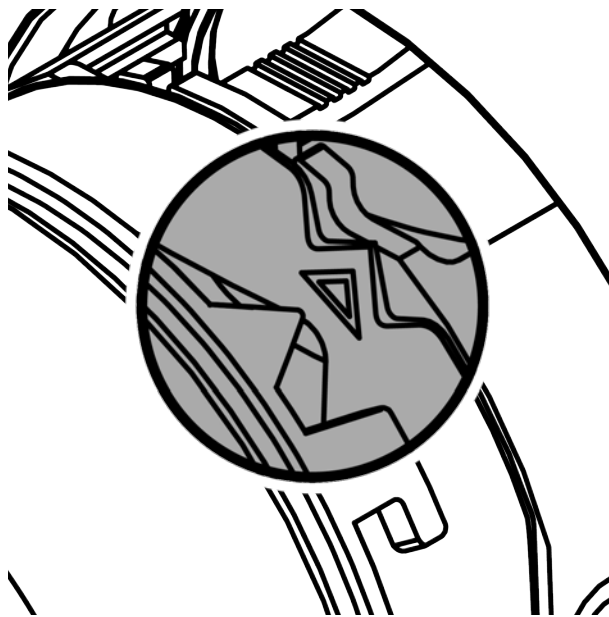

7. Turn the cover clockwise.

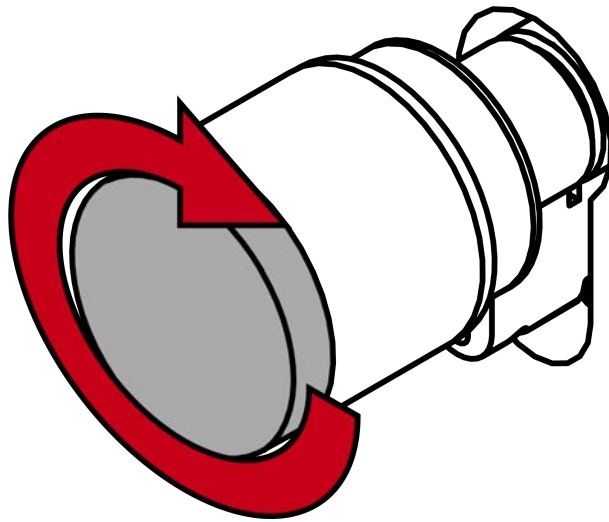

- ↳ The cover snaps into place with one click.
- ↳ The electronic thumb turn is installed.

#### Functional test

1. Turn and pull the escape thumb-turn to check that it is properly locked in position.
  2. Check that you can unlock the door with the escape thumb-turn.
- ↳ Escape thumb turn is installed.

## 10.6 Replacing the cam

- ✓ Lifter for releasing clamp present.
- ✓ Spacer for aligning the extension bolt are present.
- ✓ Suitable tool for pressing the clamp in (e.g. clamping block or fitting pliers) is available.

1. Place the SI Digital Cylinder AX in the thumb turn installation tool.

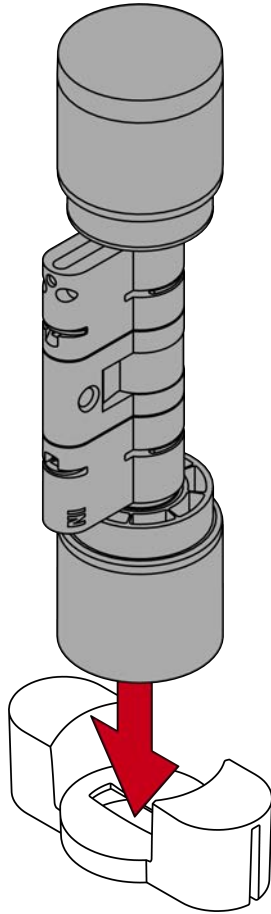

2. Attach the tip of the lifter into the clamp.

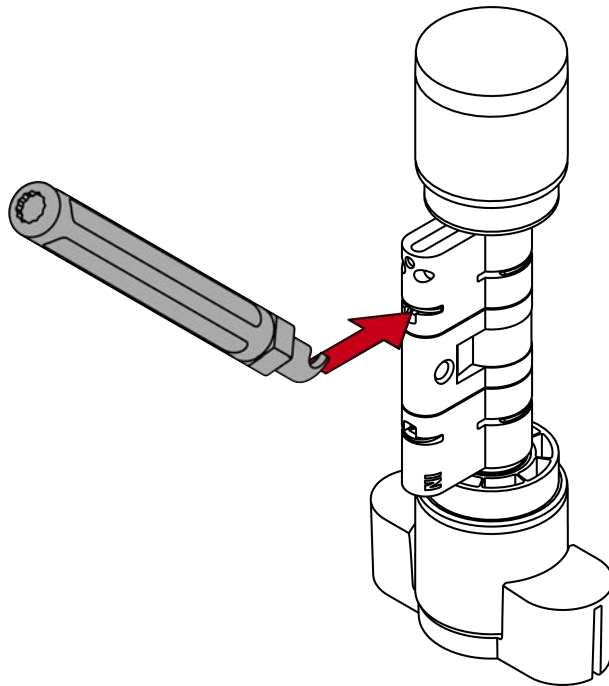

3. Lever the clamp out of the profile cylinder by positioning the lifter in the centre of the cylinder.

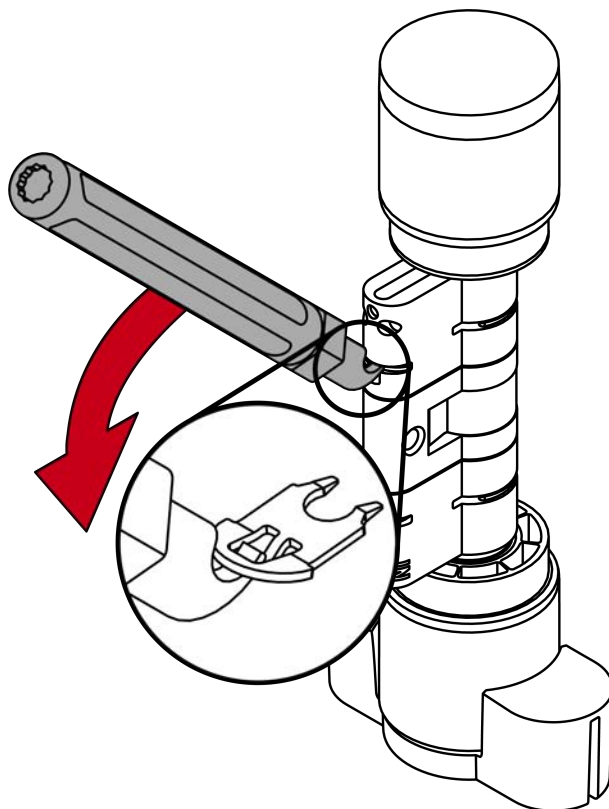

4. Pull the clamp out of the profile cylinder completely.

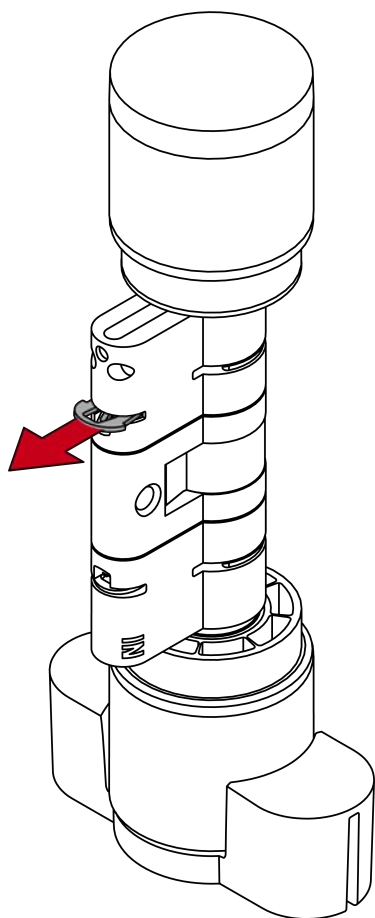

5. Disassemble the two halves of the cylinder.

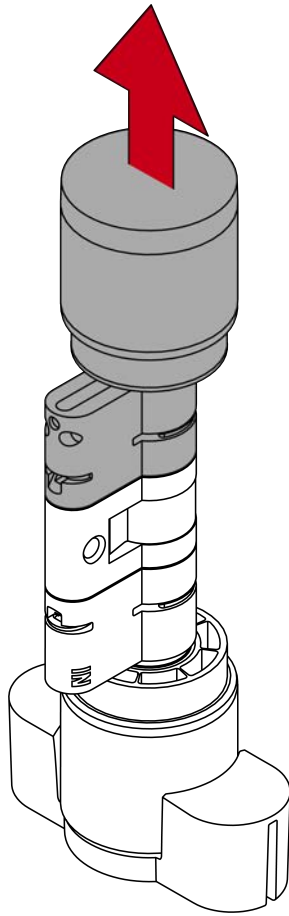

6. Attach the tip of the lifter into the second clamp.

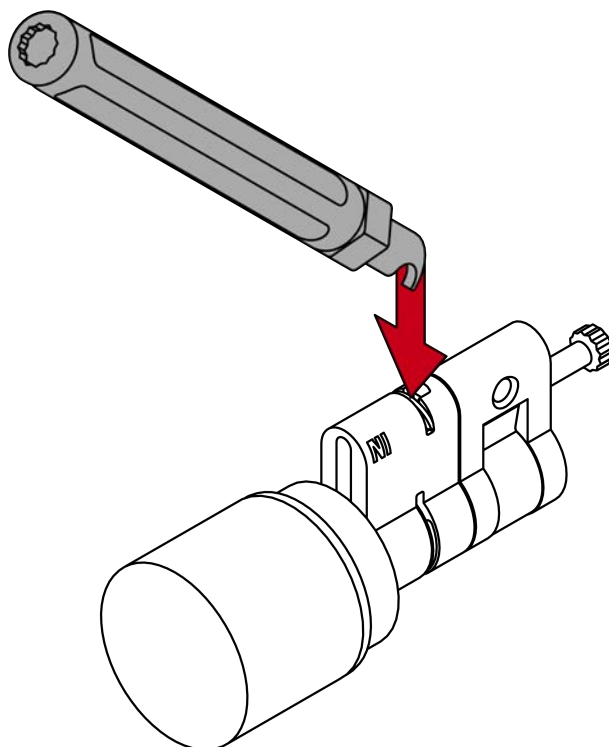

7. Lever the second clamp out of the profile cylinder by positioning the lifter in the centre of the cylinder.

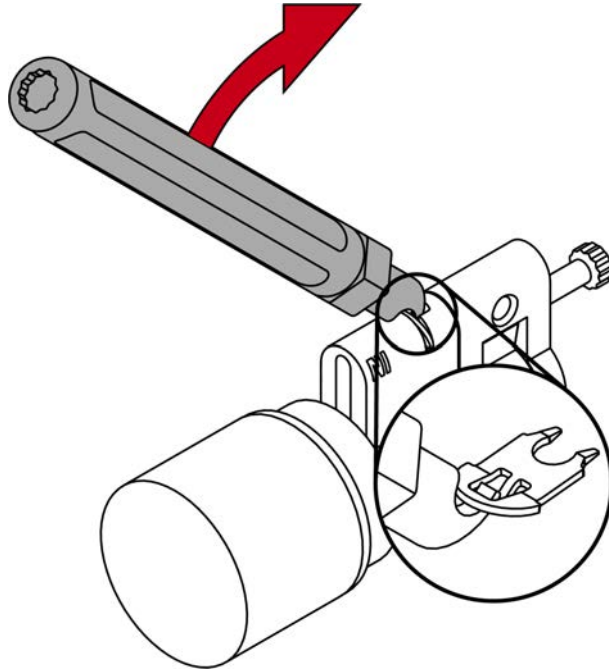

8. Pull the second clamp completely out of the profile cylinder.

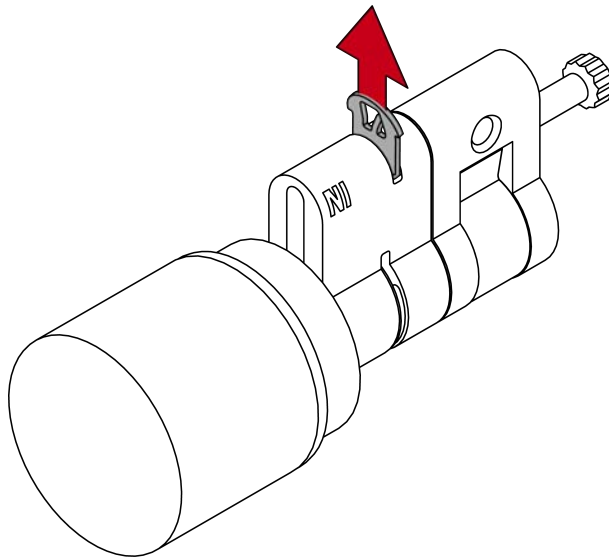

9. Unscrew both extension bolts.

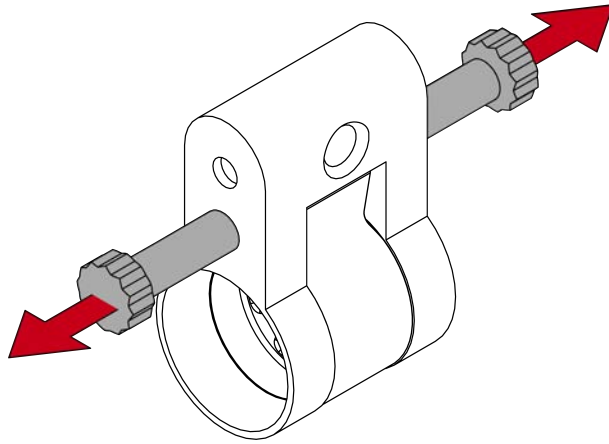

10. Remove the cam.

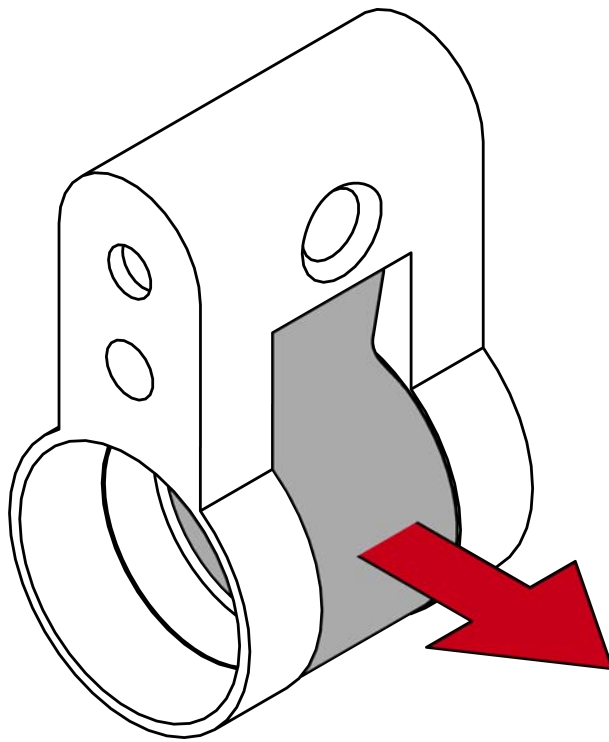



11. Insert a new cam.

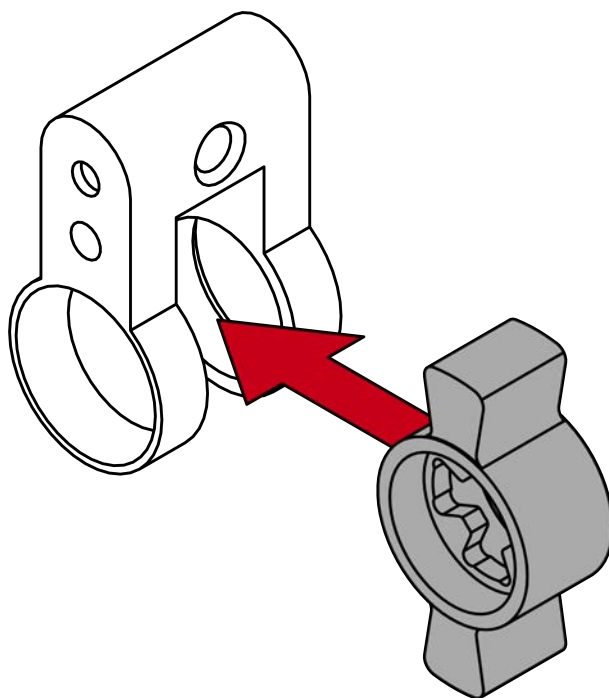

12. Fit the spacer.

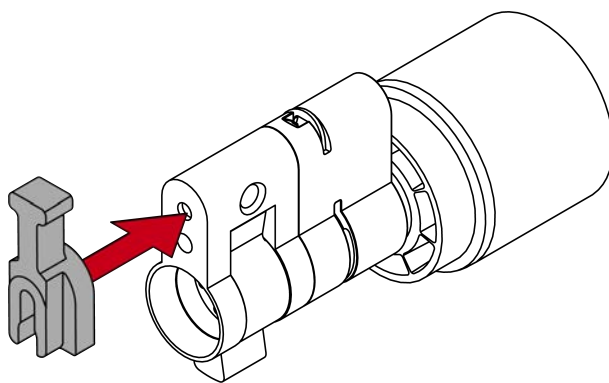

13. Using the lifter, screw in a suitable extension bolt until it is in contact with the spacer.



#### NOTE

##### Length on bolt head

You will find a number on the bolt head. This number is the length of the cylinder profile to which the bolt fits.

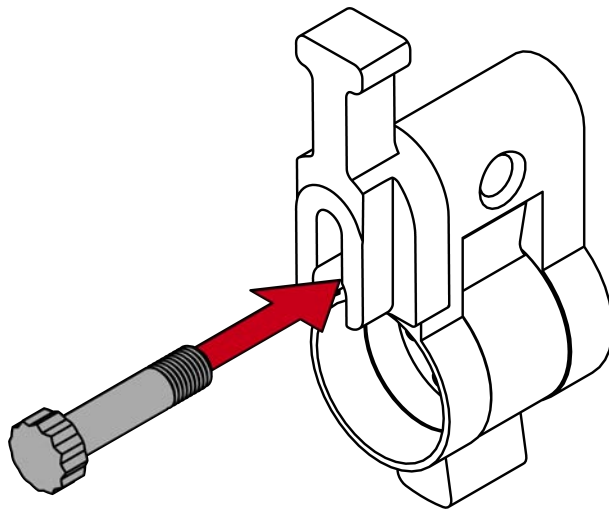

14. Place one half of the cylinder on the extension bolt.

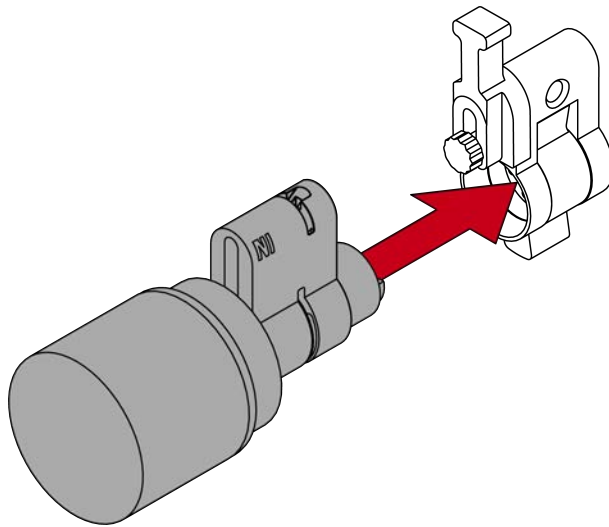

↳ Extension bolt is protected against twisting.

15. Detach the spacer again.

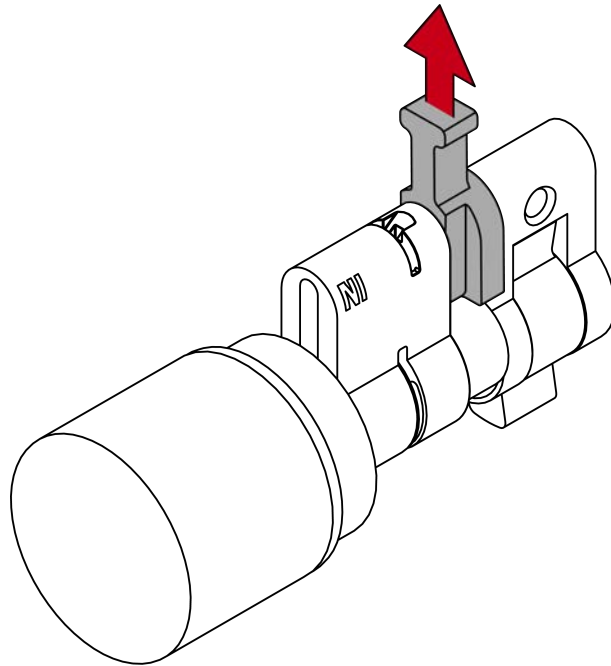

16. Push the halves together completely.

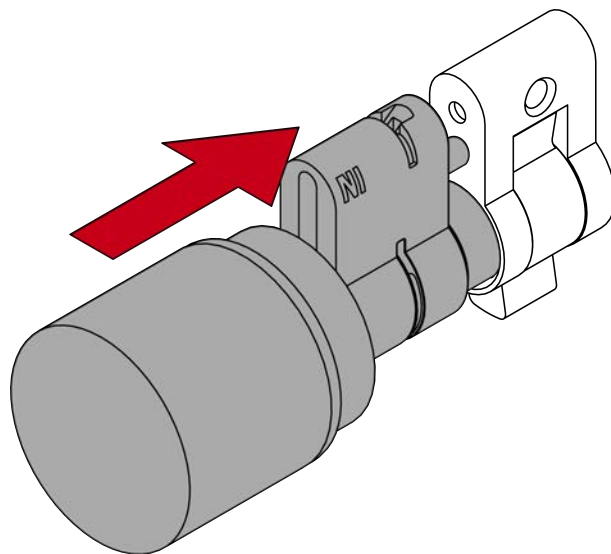

17. Insert the clamp with the tab facing the fastening screw back into the slot in the profile cylinder. Then press the clamp firmly with your thumb so that it can no longer fall out.

18. Press the clamp into the profile cylinder with a suitable tool (e.g. clamping block or fitting pliers).



**NOTE**

**Clamping block incompatible with replacement cams**

Some replacement cams do not fit into the recess in the clamping block. On cylinders with these cams, the clamps cannot be pressed in with the clamping block.

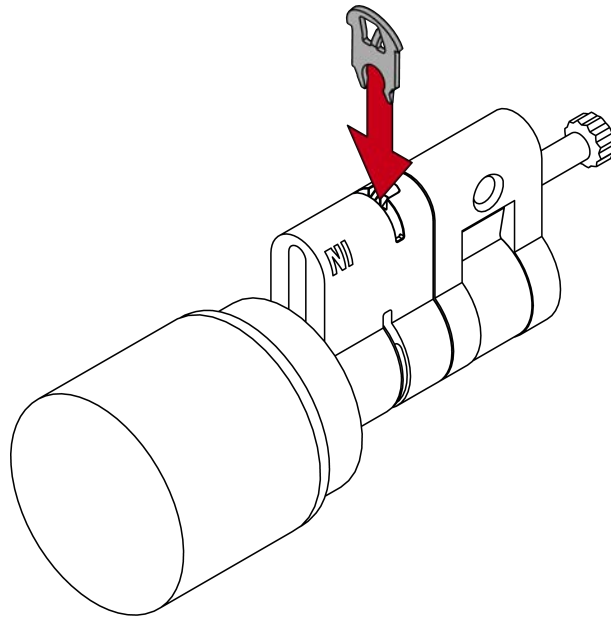

19. Refit the spacer.

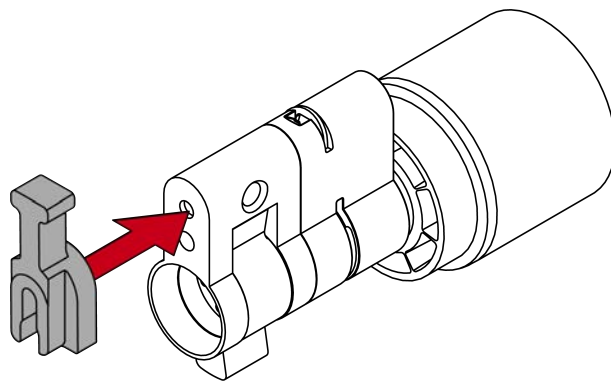

20. Using the lifter, screw in a suitable extension bolt until it is in contact with the spacer.



**NOTE**

**Length on bolt head**

You will find a number on the bolt head. This number is the length of the cylinder profile to which the bolt fits.

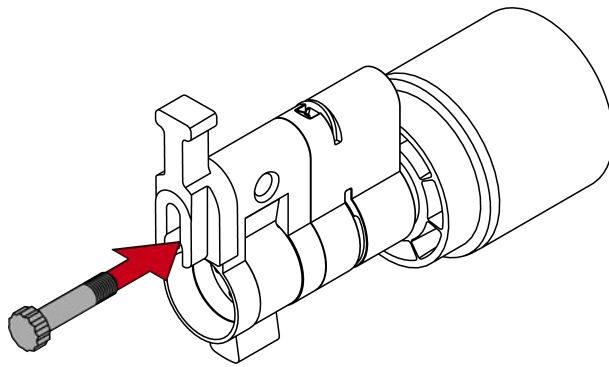

21. Place one half of the cylinder on the extension bolt.  
↳ Extension bolt is protected against twisting.

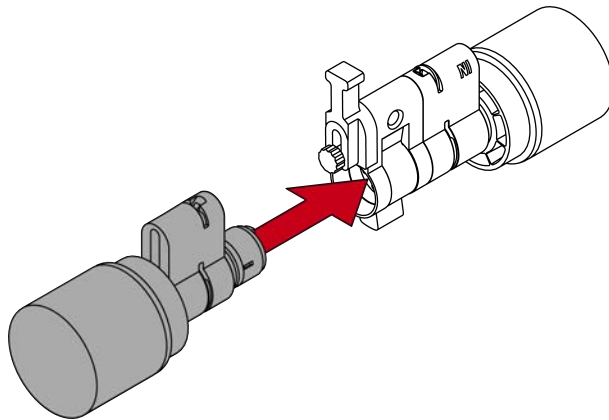

22. Detach the spacer again.

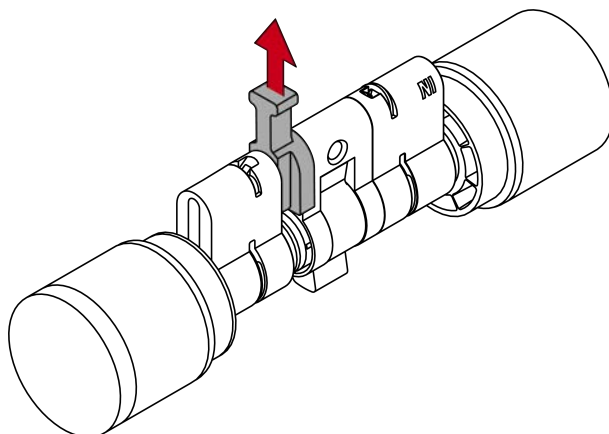

23. Push the halves together completely.

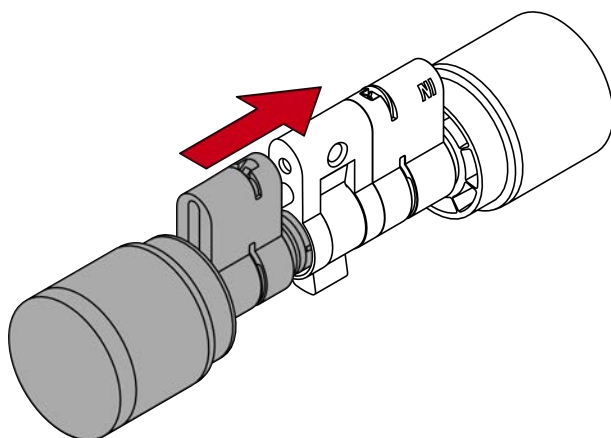

24. Insert the clamp with the tab facing the fastening screw back into the slot in the profile cylinder. Then press the clamp firmly with your thumb so that it can no longer fall out.

25. Press the clamp into the profile cylinder with a suitable tool (e.g. clamping block or fitting pliers).



#### NOTE

##### Clamping block incompatible with replacement cams

Some replacement cams do not fit into the recess in the clamping block. On cylinders with these cams, the clamps cannot be pressed in with the clamping block.

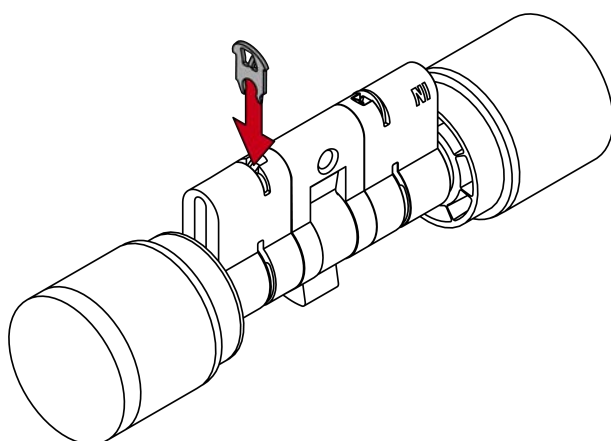

↳ Cam on the SI Digital Cylinder AX has been replaced.

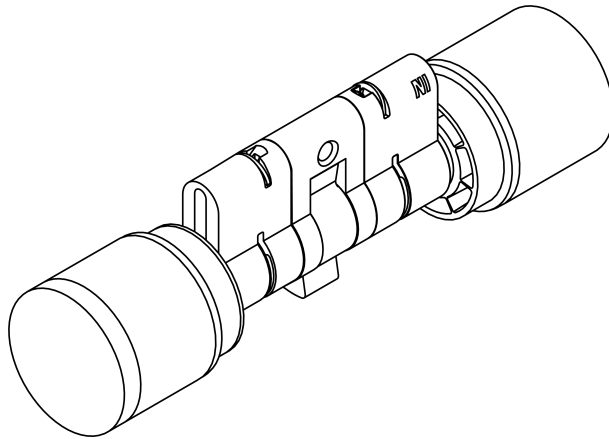

### 10.7 Replacing the lever

✓ Open-ended/ring spanner SW10 available.

1. Remove the hexagon nut (SW10).

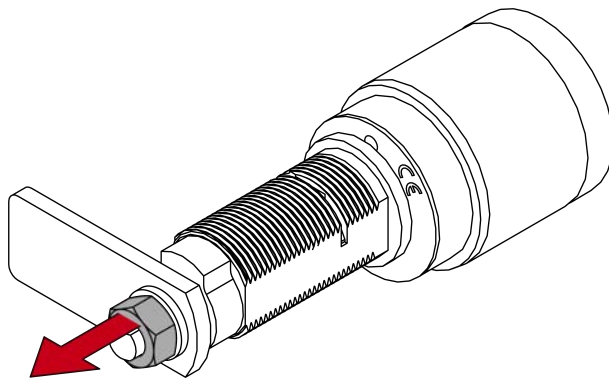

2. Remove the small washer.

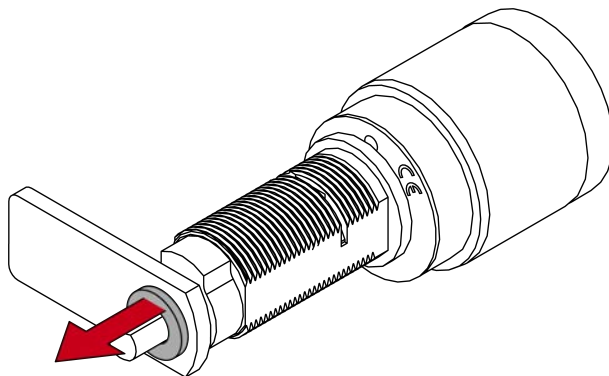

3. Remove the lever.

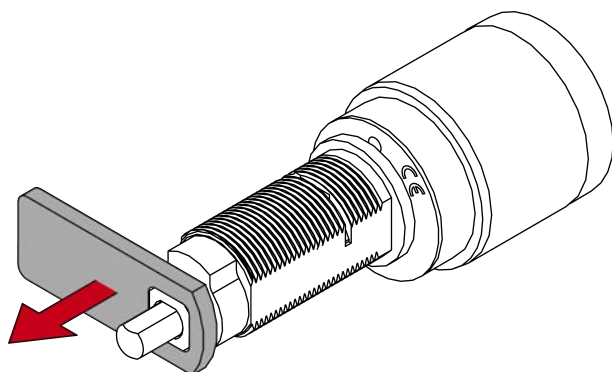

4. Place the new lever on the square bushing.

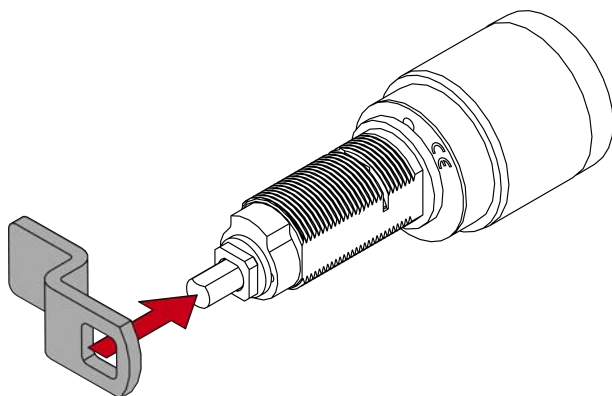

5. Place the small washer back on the lever.

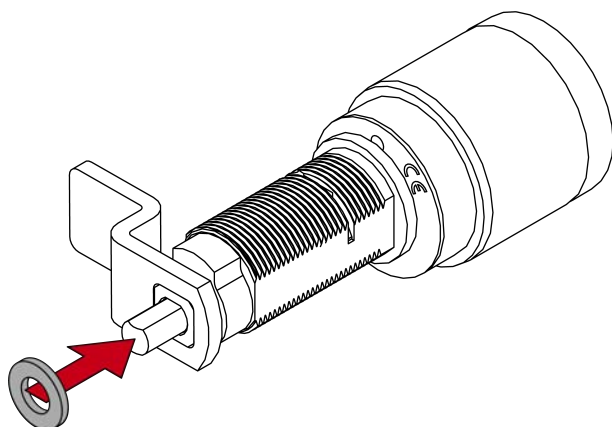



6. Screw the hexagon nut tight again (SW10).

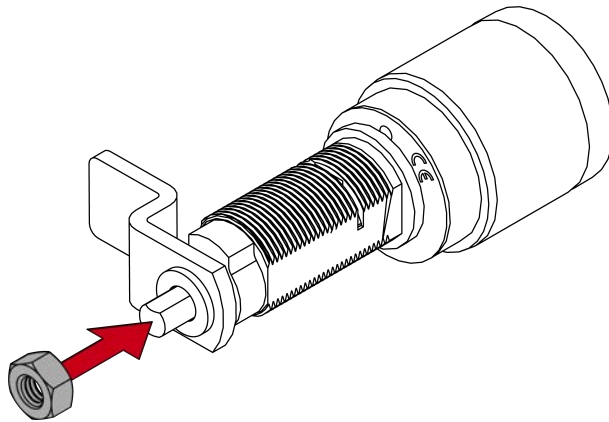

↳ Lever has been replaced.

### 10.8 Incompatible hardware versions of nodes and cores

Since the market launch of the SI Digital Cylinder AX we were also able to identify a wide range of optimisation potential through feedback from the market. This potential has now been implemented in an optimised generation of electronics.

This has resulted in improvements in terms of energy management (battery life), improved system stability at low temperatures (especially for networked components) and various other optimisations. The new generation of electronics will be delivered from August 2024.

Nothing changes in the application, all extensions and accessories are still compatible and there are no functional differences.

Components with new electronics can be recognised by the following features:

- Firmware version of the component > 1.2.1154
- Product label (star symbol before the date of manufacture)
- PZ housing (star symbol in front of the manufacturing date of the component)
- White marking on the battery compartment cover of the electronic knob
- Bezel for plug contact (socket strip for knob) is now beige instead of black

#### **IMPORTANT**

**Knobs and cores not compatible with different hardware versions**

Old and new electronics generation must not be paired.

- Please pay explicit attention to the distinguishing features listed above.

Marking on the PZ housing:



New reader knob with marked battery compartment cover is compatible with new cylinder with beige knob holder:

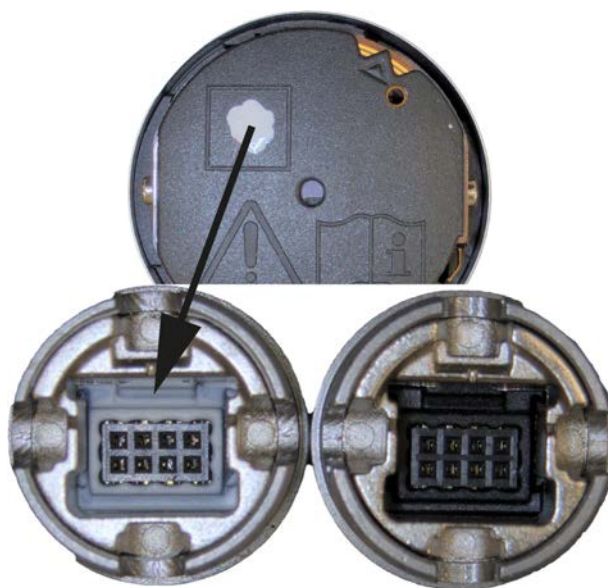

## 11. Signalling

See TechGuide WO/SVCN.

SmartIntego: Battery warnings only for SI-VCN and SI-OSS (SI-VCN: can be deactivated via Integrator system).

## 12. Maintenance

The SI Digital Cylinder AX is basically maintenance-free. You only have to change the batteries when they are weak.

Except: If you are using a self-locking half-cylinder version, the snap-in edge may wear out.

- Grease the locking edge of the control cabinet lever handle with a suitable grease (e.g. Vaseline).

### 12.1 Battery replacement



#### NOTE

##### Battery contact malfunction due to grease film

When touching batteries, leave a thin film of skin grease on the batteries. This film deteriorates the contact between the electronics and the batteries.

1. Do not touch the contacts of the new batteries with your hands.
2. Use clean and grease-free gloves.

##### Maintaining the condition during battery replacement

The SI Digital Cylinder AX cannot engage or disengage without power supply. Therefore, while the batteries are removed, the SI Digital Cylinder AX retains its current locking status and its data status (programming and stored logs).

- ✓ Special tool available.

1. Align the thumb turn horizontally.

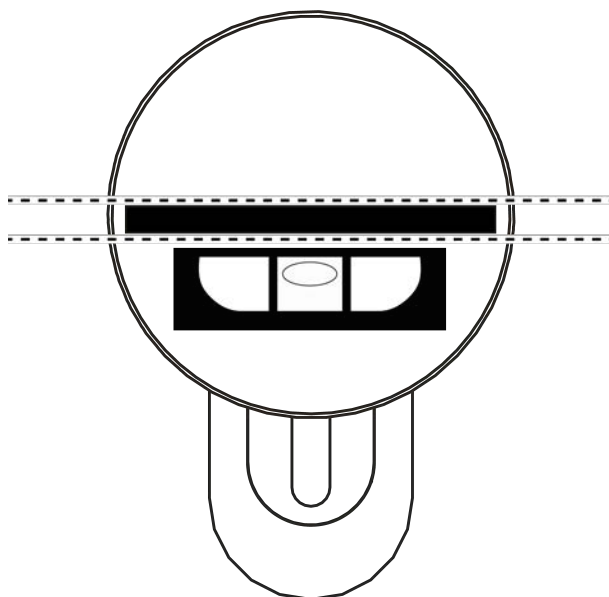

2. Attach the special tool.

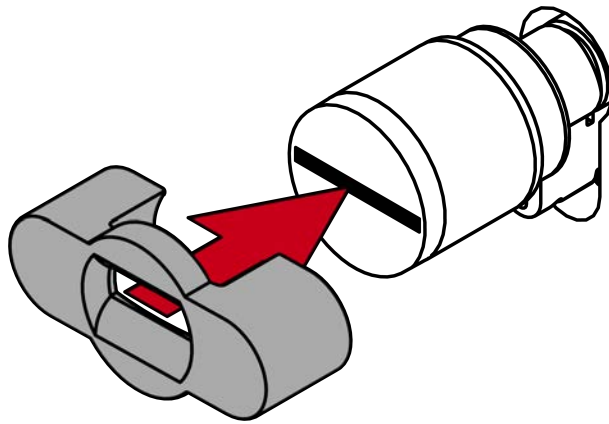

3. Align the special tool so that the logo is parallel to the recess.

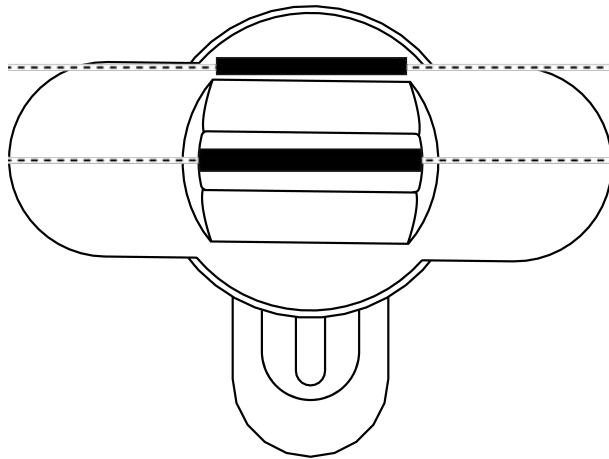

4. Hold the special tool and thumb turn cap firmly at the same time and turn them together 1-2° clockwise first and then counter-clockwise.

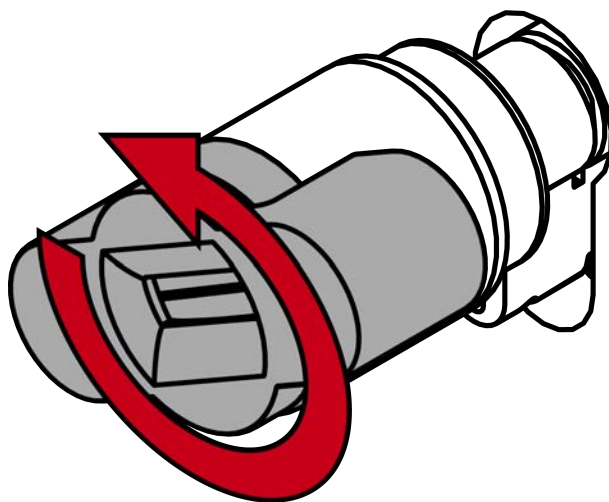

5. Remove the tool and cover.

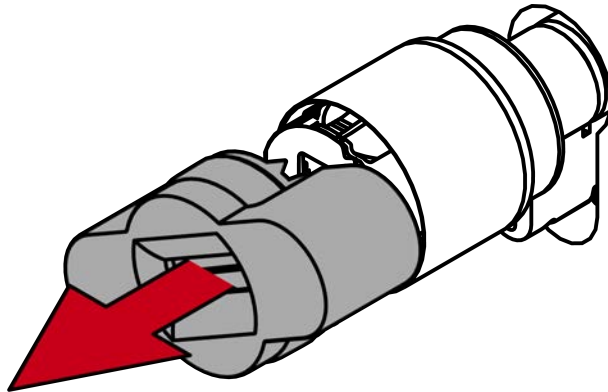

6. Push the latch inward and open the battery cover.

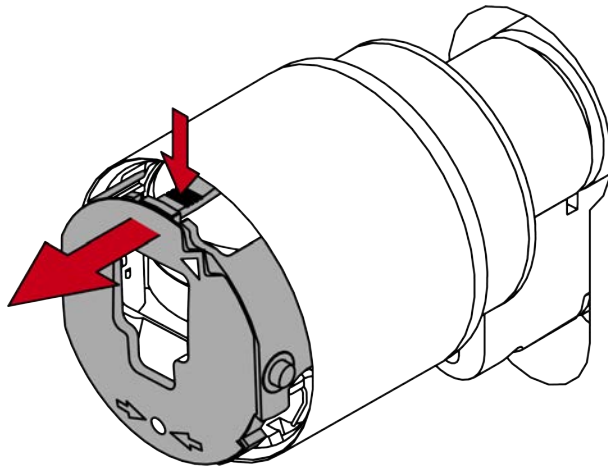

7. Remove the batteries with the special magnetic tool.

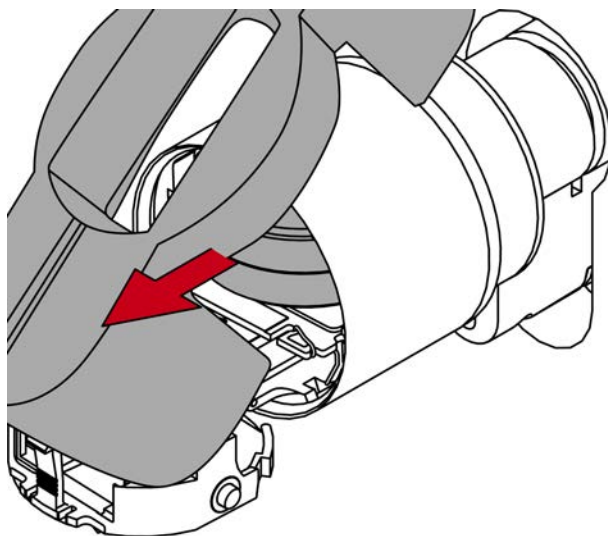

8. Insert the new batteries (positive poles touching in the middle).

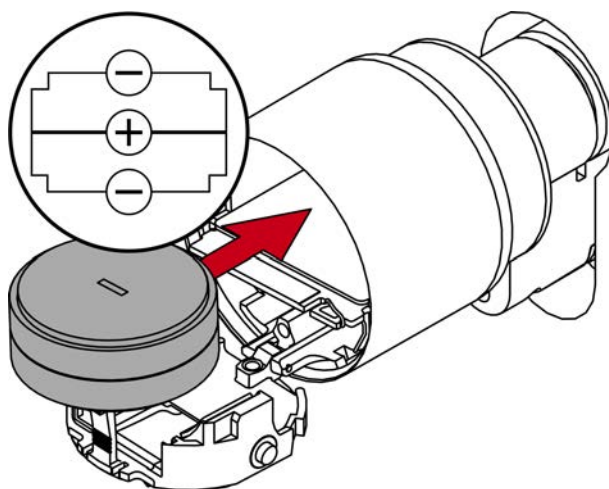

9. Close the battery cover.

↳ Cylinder signals the successful change with triple red flashing and beeping.

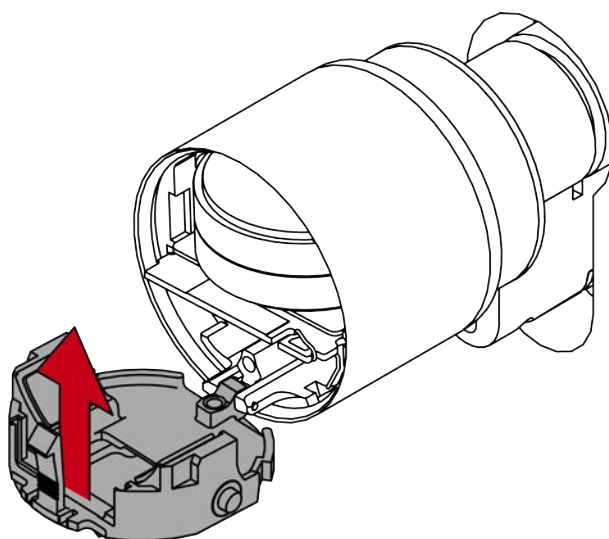

10. Put on the cover.



**NOTE**

Align the thumb-urn cover and thumb-turn using the triangles as shown in the graph.

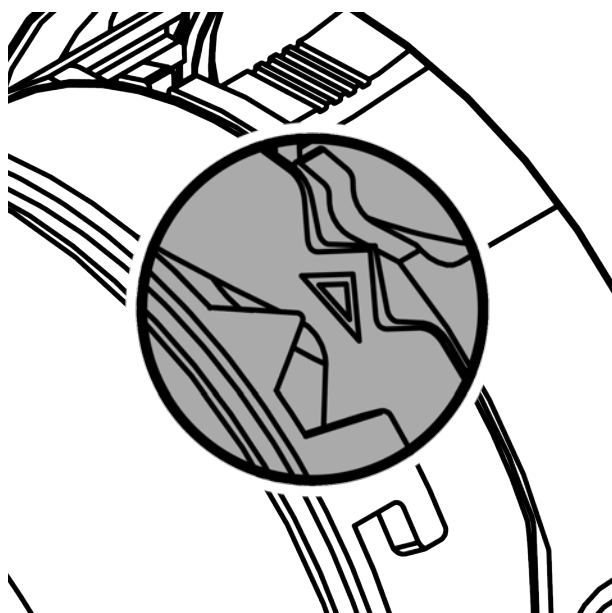
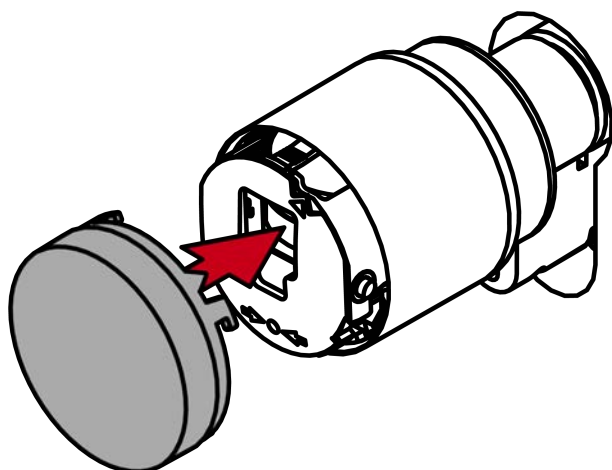

11. Turn the cover clockwise.

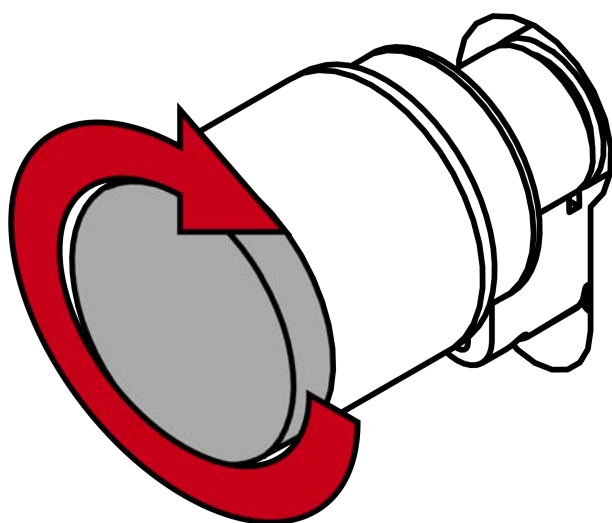

↳ The cover snaps into place with one click.



12. Carry out a function test.
  - ↳ Batteries are replaced.

## 12.2 Cleaning and disinfection

### IMPORTANT

#### Damage resulting from aggressive cleaning agents

The surface of this product may be damaged as a result of the use of unsuitable cleaning agents.

- Only use cleaning agents that are suitable for plastic or metal surfaces.

#### Damage resulting from liquids

This product contains electronic and/or mechanic components that may be damaged by liquids of any kind.

- Keep liquids away from the electronics.

Dust and dirt can impair the optical appearance. In addition, bacterial or viral contamination endangers the health of users.

1. If necessary, clean the surface with a suitable cleaning agent and a soft cloth.
2. If necessary, disinfect the surface with a suitable disinfectant.

## 13. Technical specifications

### 13.1 Euro Profile and SwissRound

Dimensions knob (Øxlength)	Ø 32 mm × 39.5 mm (electronic), Ø 32 mm × 37.5 mm (mechanical)
Basic length outside	30 mm, can be extended to 90 mm in 5 mm increments for Euro Profile (short cylinder: 25 mm, other lengths on request)
Basic length inside	30 mm, can be extended to 90 mm in 5 mm increments for Euro Profile (short cylinder: 25 mm, other lengths on request)
Material	Stainless steel
Colours	Standard: Brushed stainless steel, MS: Brass colour coated
Thumb-turn covers for reader thumb-turn	Plastic cap (passive/hybrid), metal ring cap (active), solid metal cap (active), SI: plastic cap only
VdS classification	Class BZ: applied for (Europrofile only)
SKG classification	In preparation (Europrofile only)
Weather protection	IP54 (standard), IP67 (.WP)
Temperature range (operation)	-25 °C to +65 °C (according to EN 15684)
Battery type	2x CR2450 3V (lithium) per reader thumb-turn, for battery thumb-turn: 6x
Approved battery manufacturers	Duracell, Murata, Panasonic
Battery lifetime (SI)	Up to 12 years on standby or 100,000 activations
Signalisation	Audible signal (buzzer) and/or visual signal (LED – green/red)
Network capability	Yes (integrated LockNode can be ordered and retrofitted; not approved by VdS), SI: LockNode available as replacement part for WO
Opening modes	Pulse flip-flop

Upgradeability	Firmware upgradable via BLE
----------------	-----------------------------

**Radio emissions**

13.560006 MHz - 13.560780 MHz	1.04 dB $\mu$ A/m (3 m distance)
868.000 MHz - 868.600 MHz / 869.700 MHz - 870.000 MHz Only for item numbers: SI- Z5.*M.WO*	<25 mW ERP
2402 MHz - 2480 MHz	2.5 mW

**13.2 Scandinavian Oval Scandinavian Round**

Dimensions knob (Øxlength)	Ø 32 mm × 39.5 mm (electronic), Ø 32 mm × 37.5 mm (mechanical)
Material	Stainless steel
Colours	Standard: Brushed stainless steel, MS: Brass colour coated
Thumb-turn covers for reader thumb-turn	Plastic cap (passive/hybrid), metal ring cap (active), solid metal cap (active), SI: plastic cap only
Weather protection	IP54 (standard), IP67 (.WP)
Temperature range (operation)	-25 °C to +65 °C (according to EN 15684)
Battery type	2x CR2450 3V (lithium) per reader thumb-turn, for battery thumb-turn: 6x
Approved battery manufacturers	Duracell, Murata, Panasonic
Battery lifetime (SI)	Up to 12 years on standby or 100,000 activations
Signalisation	Audible signal (buzzer) and/or visual signal (LED – green/red)
Network capability	Yes (integrated LockNode can be ordered and retrofitted; not approved by VdS), SI: LockNode available as replacement part for WO
Opening modes	Pulse flip-flop
Upgradeability	Firmware upgradable via BLE

Radio emissions

13.560006 MHz - 13.560780 MHz	1.04 dB $\mu$ A/m (3 m distance)
868.000 MHz - 868.600 MHz / 869.700 MHz - 870.000 MHz Only for item numbers: SI- Z5.*M.WO*	<25 mW ERP
2402 MHz - 2480 MHz	2.5 mW

13.3 Dimensions

CO (comfort cylinder)

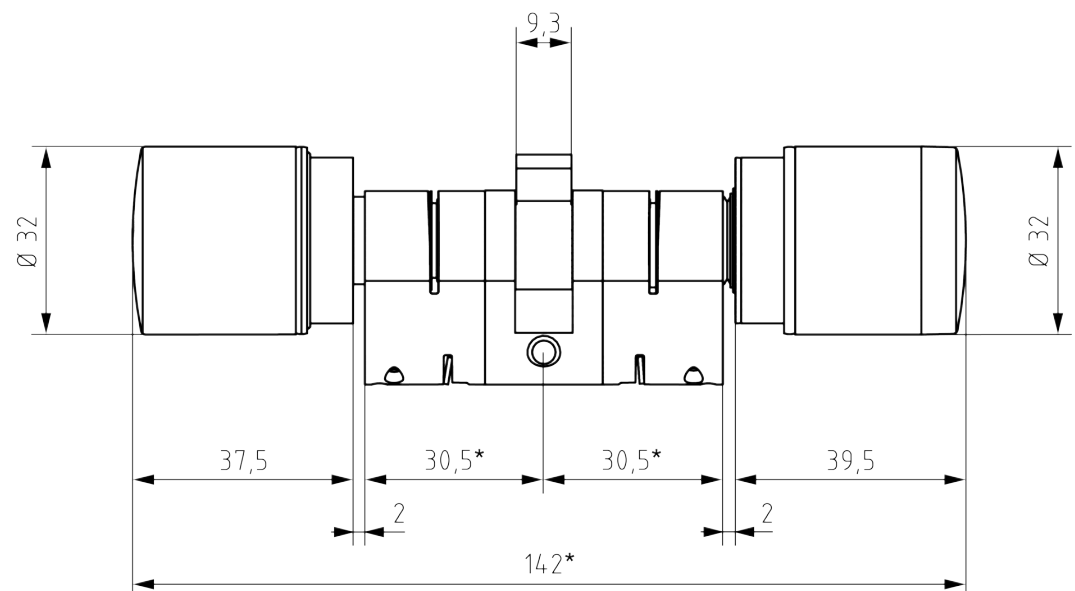

FD (free-rotating cylinder)

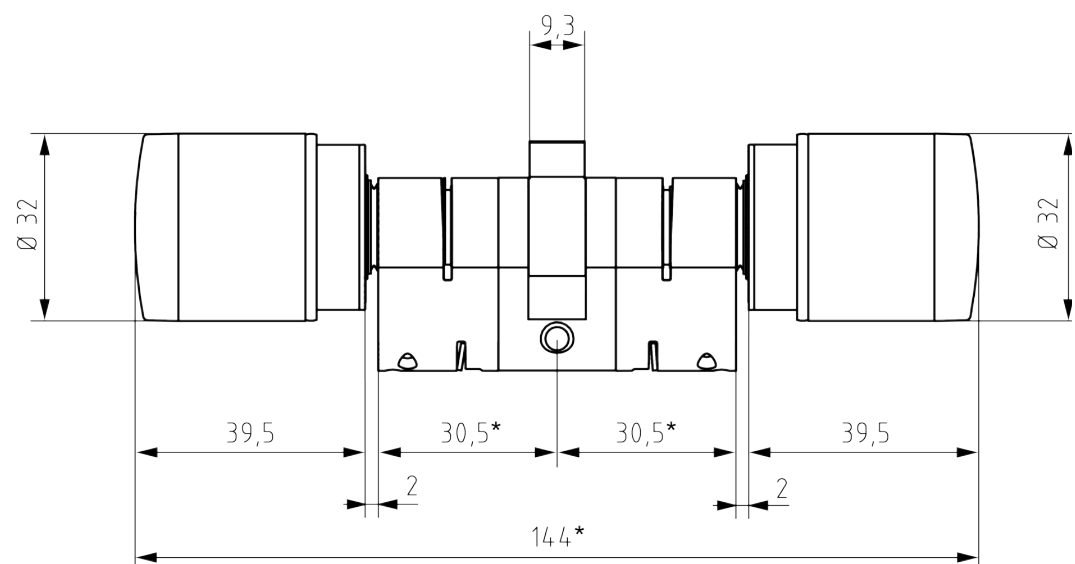

HZ (Half cylinder)

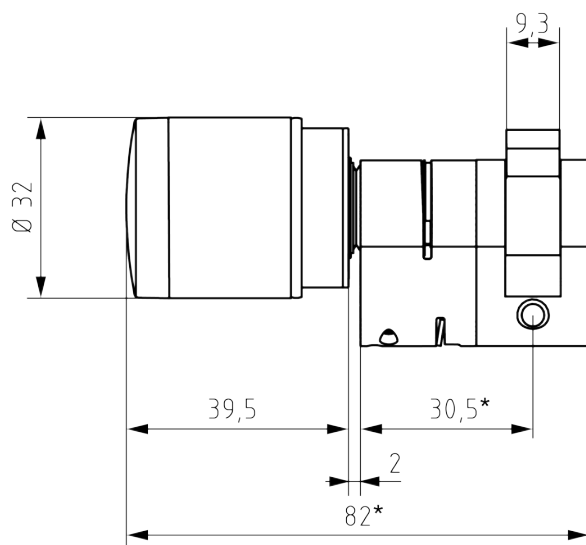

SR (Swiss Round profile)

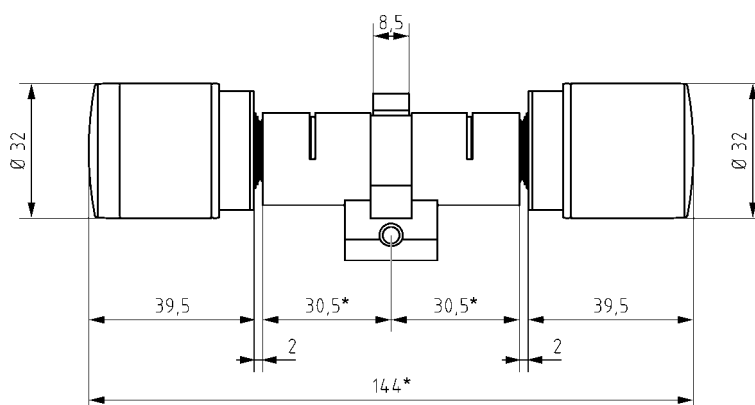

SO (Scandinavian Oval)

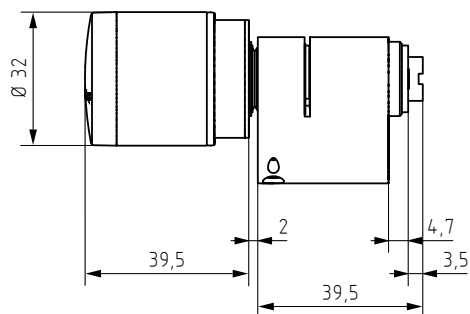

RS (Scandinavian Round)

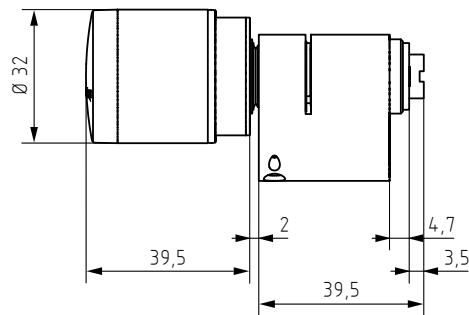

LE (lever cylinder)

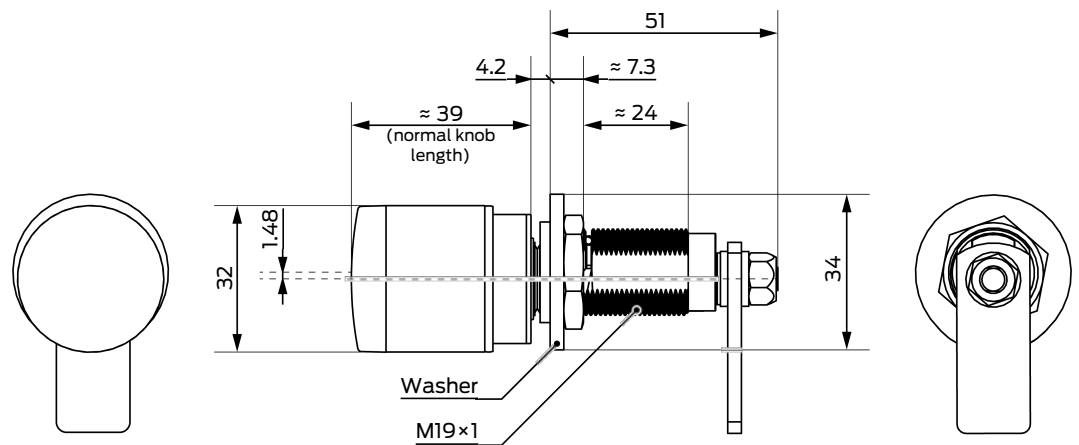

13.3.1 Cam dimensions

Standard CAM (Z5.CAM.WP)

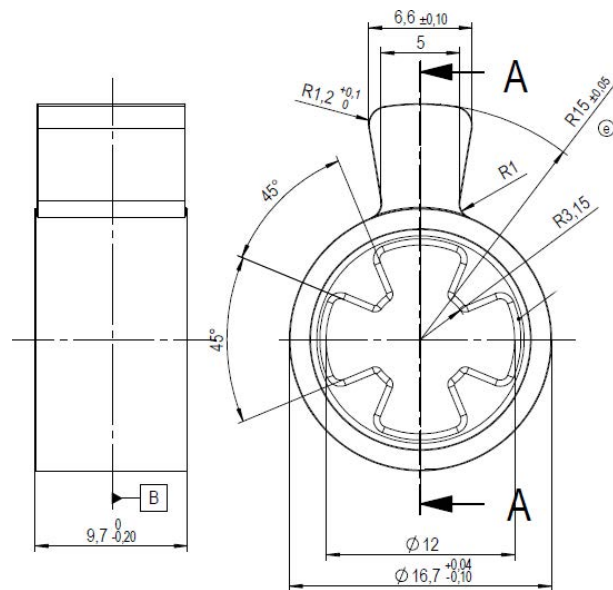

Cam PM1, long (Z5.CAM.PM1)

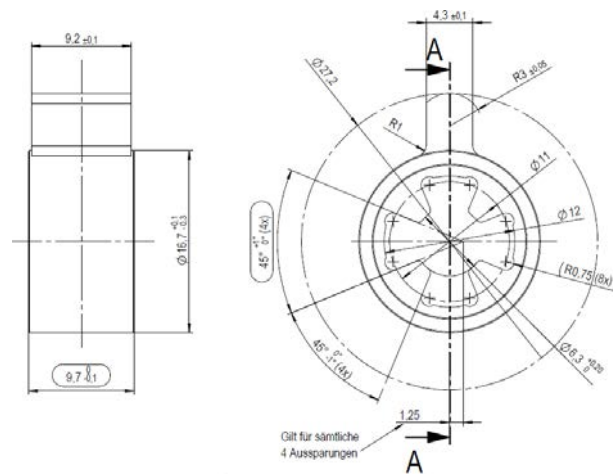

Cam PM2, short (Z5.CAM.PM2)

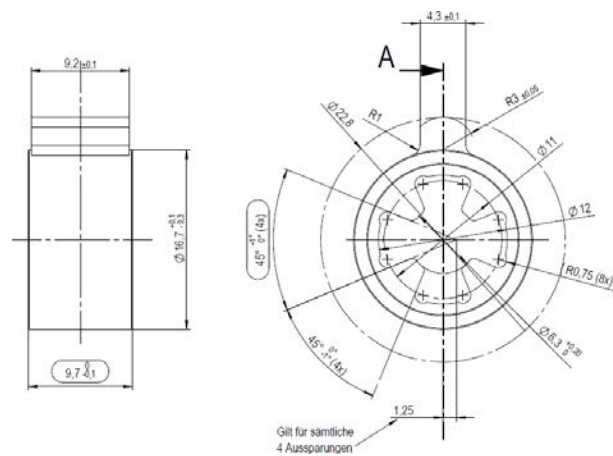

Double cam (Z5.CAM.DOUBLE)

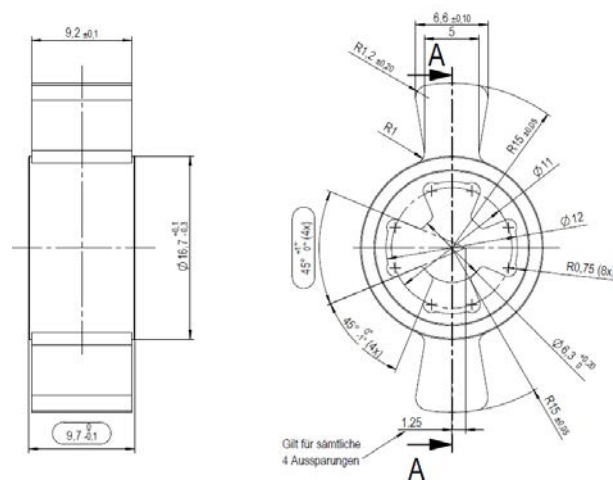

Cam gear, 10 teeth (Z5.CAM.GEAR10)

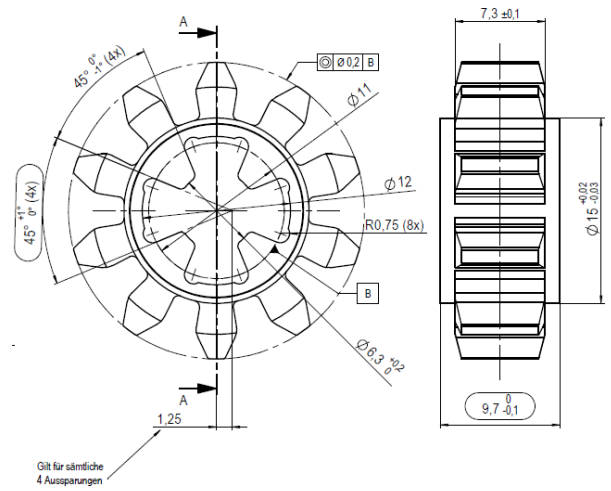

Module	m	2
Number of teeth	z	10
Flank diameter	d	20

Cam gear, 18 teeth (Z5.CAM.GEAR18)

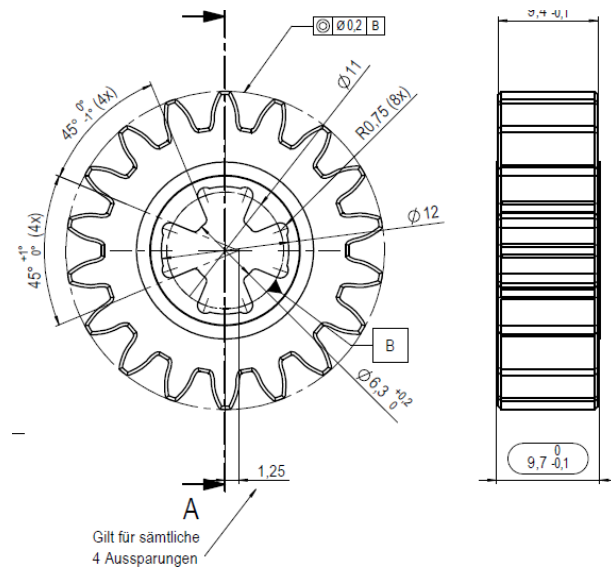

Module	m	1.5
Number of teeth	z	18
Flank diameter	d	27



13.3.2 Lever dimensions

Z5.LE.11.01

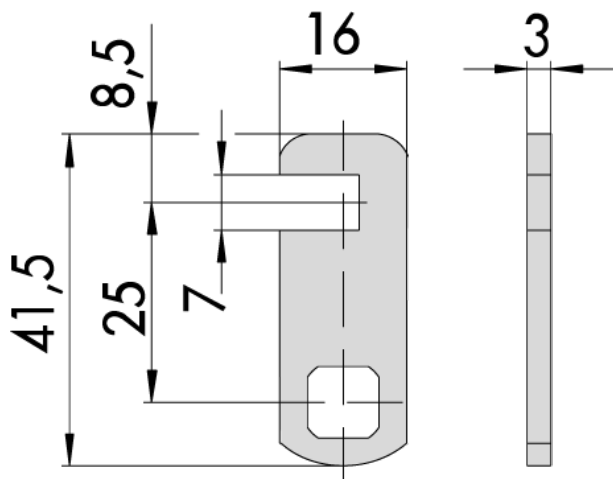

Z5.LE.11.02

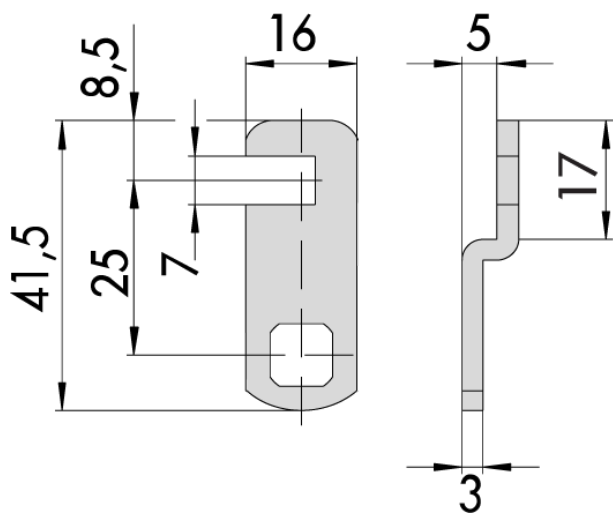

Z5.LE.11.03

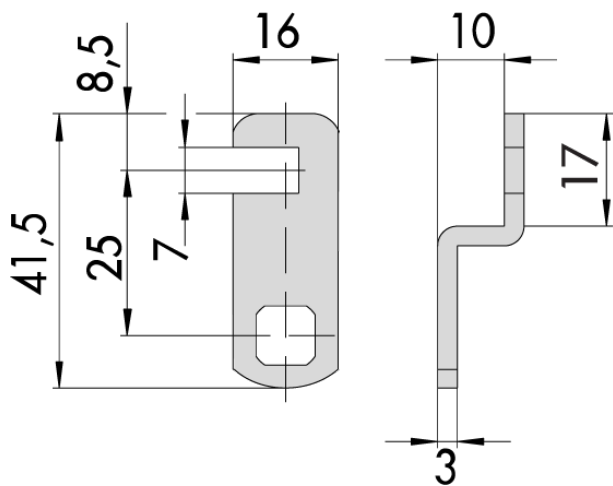

Z5.LE.11.04

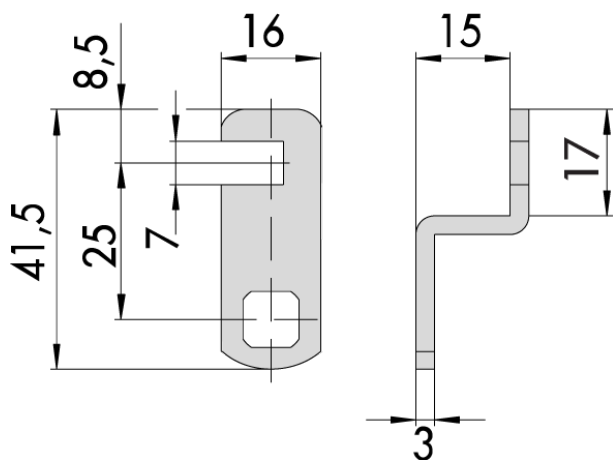

Z5.LE.12.01

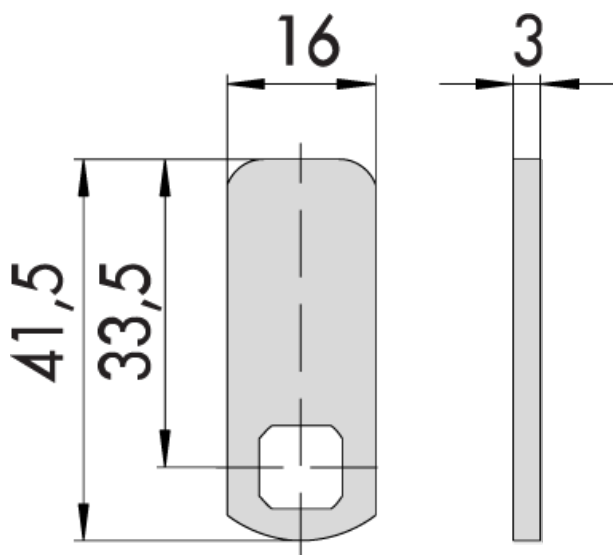

Z5.LE.12.02

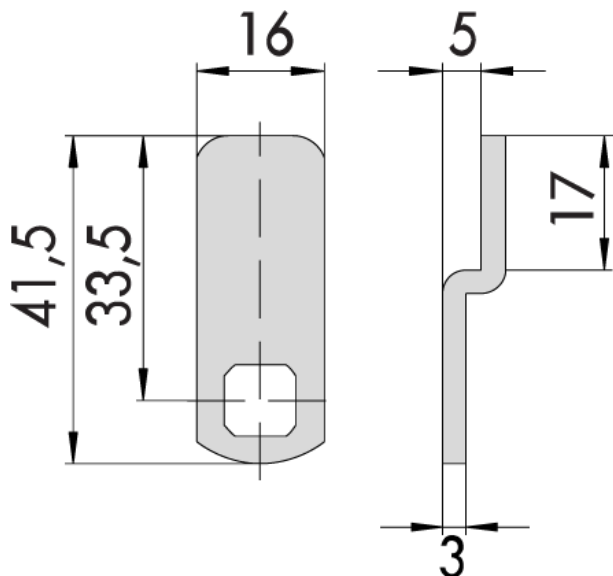

Z5.LE.12.03

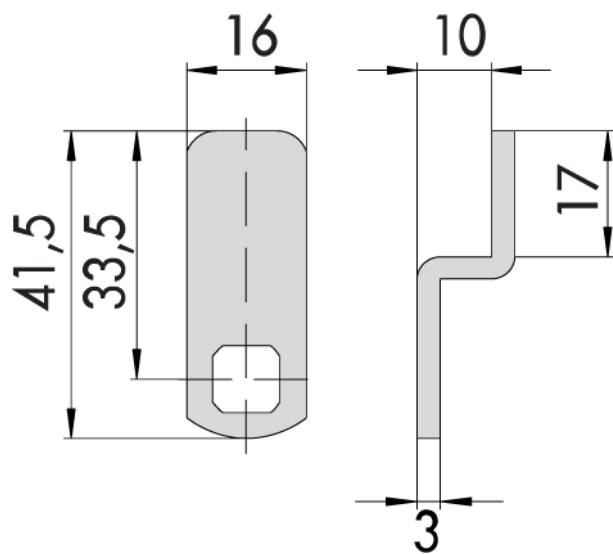

Z5.LE.12.04

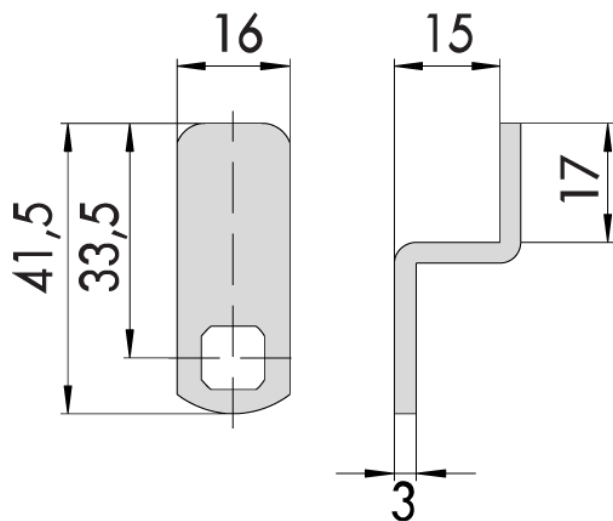

## 14. Declaration of conformity

The company SimonsVoss Technologies GmbH hereby declares that the articles (SI-Z5.\*M.VCN\*, SI-Z5.\*M.WO\*, SI-Z5.\*M.OSS\*) comply with the following guidelines:

- 2014/53/EU -RED-  
or for the UK: UK statutory 2017 No. 1206 -Radio equipment-
- 2011/65/EU -RoHS-  
or for the UK: UK statutory 2012 No. 3032 -RoHS-



The full text of the EU Declaration of conformity is available at the following internet address: [www.simons-voss.com/en/certificates.html](http://www.simons-voss.com/en/certificates.html).

The full text of the UK Declaration of conformity is available at the following internet address: [www.simons-voss.com/en/certificates.html](http://www.simons-voss.com/en/certificates.html).

## 15. Help and other information

### Information material/documents

You will find detailed information on operation and configuration and other documents on the website:

<https://www.smartintego.com/int/home/infocenter/documentation>

### Declarations of conformity

You will find declarations of conformity and other certificates on the website:

<https://www.simons-voss.com/en/certificates.html>

### Information on disposal

- Do not dispose the device (SI-Z5.\*M.VCN\*, SI-Z5.\*M.WO\*, SI-Z5.\*M.OSS\*) in the household waste. Dispose of it at a collection point for electronic waste as per European Directive 2012/19/EU.
- Recycle defective or used batteries in line with European Directive 2006/66/EC.
- Observe local regulations on separate disposal of batteries.
- Take the packaging to an environmentally responsible recycling point.



### Technical support

Our technical support will be happy to help you (landline, costs depend on provider):

+49 (0) 89 / 99 228 333

### Email

You may prefer to send us an email.

[si-support-simonsvoss@allegion.com](mailto:si-support-simonsvoss@allegion.com)

### FAQs

You will find information and help in the FAQ section:

<https://faq.simons-voss.com/otrs/public.pl>

**Address**

SimonsVoss Technologies GmbH  
Feringastr. 4  
D-85774 Unterfoehring  
Germany



## This is SimonsVoss

SimonsVoss, the pioneer in remote-controlled, cable-free locking technology provides system solutions with a wide range of products for SOHOs, SMEs, major companies and public institutions. SimonsVoss locking systems combine intelligent functionality, high quality and award-winning design Made in Germany.

As an innovative system provider, SimonsVoss focuses on scalable systems, high security, reliable components, powerful software and simple operation. As such, SimonsVoss is regarded as a technology leader in digital locking systems.

Our commercial success lies in the courage to innovate, sustainable thinking and action, and heartfelt appreciation of employees and partners.

SimonsVoss is a company in the ALLEGION Group, a globally active network in the security sector. Allegion is represented in around 130 countries worldwide ([www.allegion.com](http://www.allegion.com)).

### Made in Germany

SimonsVoss is truly committed to Germany as a manufacturing location: all products are developed and produced exclusively in Germany.

© 2025, SimonsVoss Technologies GmbH, Unterföhring

All rights are reserved. Text, images and diagrams are protected under copyright law.

The content of this document must not be copied, distributed or modified. More information about this product can be found on the SimonsVoss website. Subject to technical changes.

SimonsVoss and MobileKey are registered brands belonging to SimonsVoss Technologies GmbH.

**SimonsVoss**  
technologies

Made in Germany

A BRAND OF

  
**ALLEGION**